

## FEATURES

- Converts Remote Sensor or Internal Diode Temperature to Analog Voltage
- $\pm 1^{\circ}\text{C}$  Remote Temperature Accuracy
- $\pm 1.5^{\circ}\text{C}$  Internal Temperature Accuracy
- Built-In Series Resistance Cancellation
- 2.5V to 5.5V Supply Voltage
- 1.8V Reference Voltage Output
- 3.5ms  $V_{\text{PTAT}}$  Update Time
- 4mV/ $^{\circ}\text{K}$  Output Gain
- 170 $\mu\text{A}$  Quiescent Current
- Available in 6-Pin 2mm  $\times$  3mm DFN Package

## APPLICATIONS

- Temperature Measurement
- Remote Temperature Measurement
- Environmental Monitoring
- System Thermal Control
- Desktop and Notebook Computers
- Network Servers

## DESCRIPTION

The LTC<sup>®</sup>2997 is a high-accuracy analog output temperature sensor. It converts the temperature of an external sensor or its own temperature to an analog voltage output. A built-in algorithm eliminates errors due to series resistance between the LTC2997 and the sensor diode.

The LTC2997 gives accurate results with low-cost diode-connected NPN or PNP transistors or with integrated temperature transistors on microprocessors or FPGAs. Tying pin D<sup>+</sup> to V<sub>CC</sub> configures the LTC2997 to measure its internal temperature.

The LTC2997 provides an additional 1.8V reference voltage output which can be used as an ADC reference input or for generating temperature threshold voltages to compare against the V<sub>PTAT</sub> output.

The LTC2997 provides a precise and versatile micropower solution for accurate temperature sensing.

LT, LT, LTC, LTM, Linear Technology and the Linear logo are registered trademarks of Linear Technology Corporation. All other trademarks are the property of their respective owners.

## TYPICAL APPLICATION

Single Remote Temperature Sensor

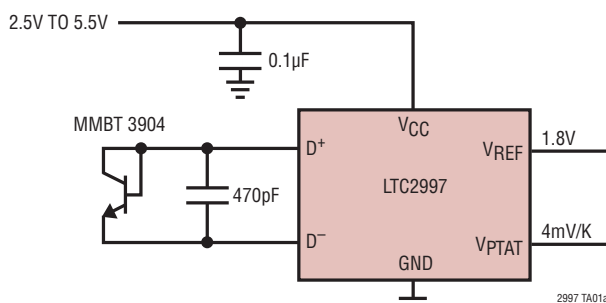

V<sub>PTAT</sub> vs Remote Sensor Temperature

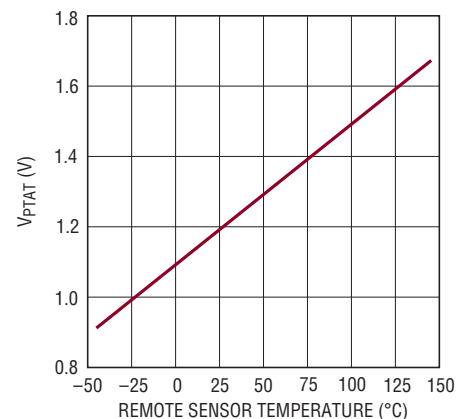

## ABSOLUTE MAXIMUM RATINGS

(Notes 1, 2)

### Terminal Voltages

$V_{CC}$  ..... -0.3V to 6V  
 $D^+$ ,  $D^-$ ,  $V_{PTAT}$ ,  $V_{REF}$  ..... -0.3V to  $V_{CC} + 0.3V$

### Operating Ambient Temperature Range

LTC2997C ..... 0°C to 70°C  
 LTC2997I ..... -40°C to 85°C  
 LTC2997H ..... -40°C to 125°C

Storage Temperature Range ..... -65°C to 150°C

## PIN CONFIGURATION

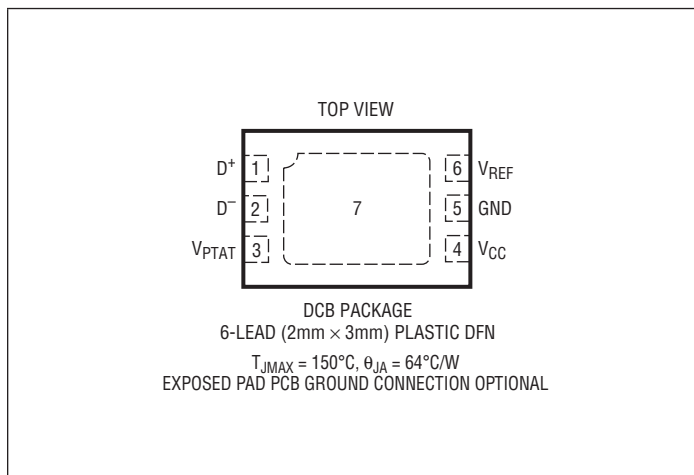

## ORDER INFORMATION

### Lead Free Finish

TAPE AND REEL (MINI)	TAPE AND REEL	PART MARKING*	PACKAGE DESCRIPTION	TEMPERATURE RANGE
LTC2997CDCB#TRMPBF	LTC2997CDCB#TRPBF	LFQZ	6-Lead (2mm × 3mm) Plastic DFN	0°C to 70°C
LTC2997IDCB#TRMPBF	LTC2997IDCB#TRPBF	LFQZ	6-Lead (2mm × 3mm) Plastic DFN	-40°C to 85°C
LTC2997HDCB#TRMPBF	LTC2997HDCB#TRPBF	LFQZ	6-Lead (2mm × 3mm) Plastic DFN	-40°C to 125°C

TRM = 500 pieces. \*Temperature grades are identified by a label on the shipping container.

Consult LTC Marketing for parts specified with wider operating temperature ranges.

Consult LTC Marketing for information on lead based finish parts.

For more information on lead free part marking, go to: <http://www.linear.com/leadfree/>

For more information on tape and reel specifications, go to: <http://www.linear.com/tapeandreel/>

## ELECTRICAL CHARACTERISTICS

The ● denotes the specifications which apply over the full operating temperature range, otherwise specifications are at  $T_A = 25^\circ\text{C}$ ,  $V_{CC} = 3.3\text{V}$ , unless otherwise noted.

SYMBOL	PARAMETER	CONDITIONS	MIN	TYP	MAX	UNITS	
$V_{CC}$	Supply Voltage		● 2.5	3.3	5.5	V	
UVLO	Supply Undervoltage Lockout Threshold	$V_{CC}$ Falling	● 1.7	1.9	2.1	V	
$I_{CC}$	Average Supply Current		● 120	170	250	$\mu\text{A}$	
<b>Temperature Monitoring</b>							
$V_{REF}$	Reference Voltage	LTC2997	●	1.797	1.8	1.803	V
		LTC2997C	●	1.793	1.8	1.804	V
		LTC2997I	●	1.790	1.8	1.807	V
		LTC2997H	●	1.787	1.8	1.808	V
	$V_{REF}$ Load Regulation Error	$I_{LOAD} = \pm 200\mu\text{A}$ ; $V_{CC} = 3.3\text{V}$	●		$\pm 1.5$	mV	
	Remote Sense Current			-8	-192	$\mu\text{A}$	
	Diode Select Threshold	(Note 3)	●	$V_{CC} - 600$	$V_{CC} - 300$	$V_{CC} - 100$	mV
$T_{UPDATE}$	Temperature Update Interval			3.5	5	ms	
$K_T$	$V_{PTAT}$ Slope	$\eta = 1.004$ (Note 4)		4		mV/ $^\circ\text{K}$	
	$V_{PTAT}$ Load Regulation	$I_{LOAD} = \pm 200\mu\text{A}$ ; $V_{CC} = 3.3\text{V}$ (Note 7)			$\pm 1.5$	mV	
$T_{INT}$	Internal Temperature Error	LTC2997C, LTC2997I	●	$\pm 0.5$	$\pm 1.5$	$^\circ\text{C}$	
		LTC2997H	●		$\pm 2$	$^\circ\text{C}$	
$T_{RMT}$	Remote Temperature Error, $\eta = 1.004$	$0^\circ\text{C}$ to $100^\circ\text{C}$ (Notes 5, 7)		$\pm 0.25$	$\pm 1$	$^\circ\text{C}$	
		$-40^\circ\text{C}$ to $0^\circ\text{C}$ (Notes 5, 7)		$\pm 0.25$	$\pm 1.5$	$^\circ\text{C}$	
		$100^\circ\text{C}$ to $125^\circ\text{C}$ (Notes 5, 7)			$\pm 1.5$	$^\circ\text{C}$	
$T_{VCC}$	Temperature Error vs Supply	$2.5\text{V} \leq V_{CC} \leq 5.5\text{V}$	●	$\pm 0.1$	$\pm 1$	$^\circ\text{C}/\text{V}$	
$T_{RS}$	Series Resistance Cancellation Error	$R_{SERIES} = 100\Omega$ —	●	$\pm 0.25$	$\pm 1$	$^\circ\text{C}$	
	Temperature Noise	(Note 6)		0.25	0.015	$^\circ\text{C RMS}$ $^\circ\text{C}/\sqrt{\text{Hz}}$	

**Note 1:** Stresses beyond those listed under Absolute Maximum Ratings may cause permanent damage to the device. Exposure to any Absolute Maximum Rating condition for extended periods may affect device reliability and lifetime.

**Note 2:** All currents into pins are positive; all voltages are referenced to GND unless otherwise noted.

**Note 3:** If voltage on pin  $D^+$  exceeds the diode select threshold the LTC2997 uses the internal diode sensor.

**Note 4:**  $\eta$  = ideality factor of remote diode

**Note 5:** Remote diode temperature.

**Note 6:** Guaranteed by design and not subject to test.

**Note 7:** Guaranteed by design and test correlation.

## TYPICAL PERFORMANCE CHARACTERISTICS $T_A = 25^\circ\text{C}$ , $V_{CC} = 3.3\text{V}$ unless otherwise noted.

**Temperature Error with LTC2997 at Same Temperature as Remote Diode**

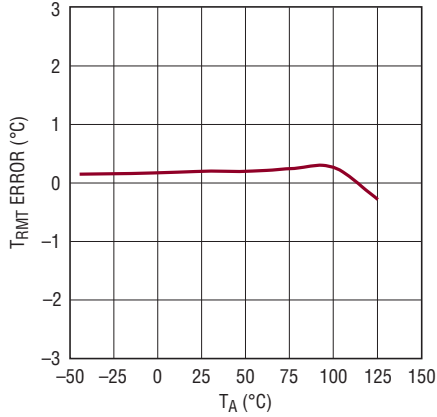

2997 G01

**Remote Temperature Error vs  $T_A$  with Remote Diode at  $25^\circ\text{C}$**

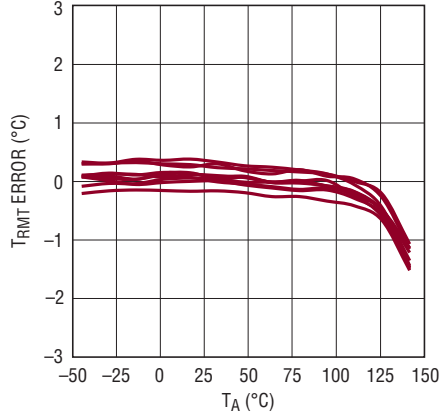

2997 G02

**Internal Temperature Error vs  $T_A$ ,  $T_{INT}$**

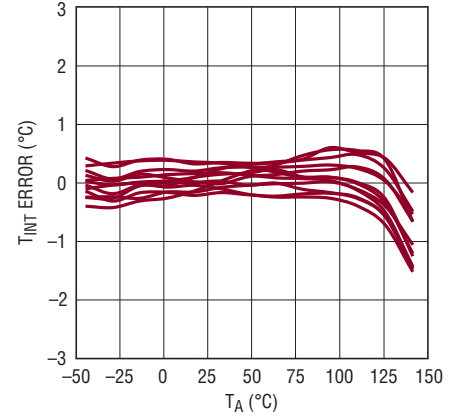

2997 G03

**Temperature Error vs  $V_{CC}$  - Remote/Internal,  $T_{VCC}$**

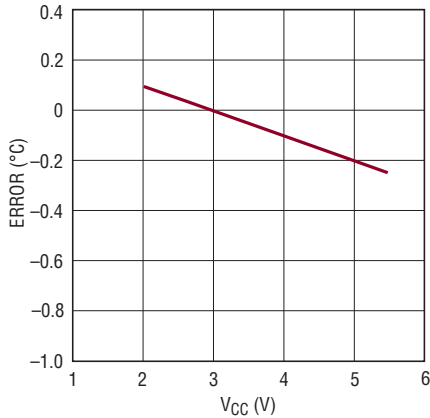

2997 G04

**Remote Temperature Error vs Series Resistance,  $T_{RS}$**

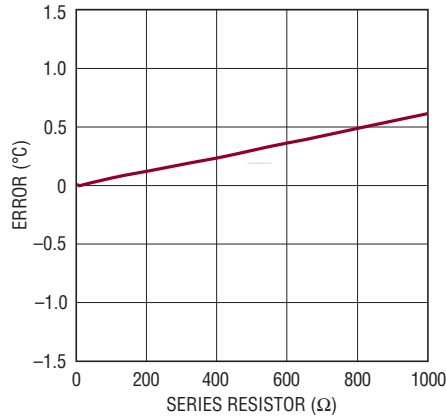

2997 G05

**Remote Temperature Error vs  $C_{DECOUPLE}$  (Between  $D^+$  and  $D^-$ )**

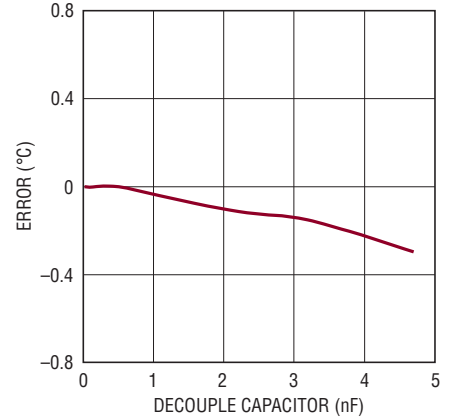

2997 G06

**$V_{PTAT}$  Noise vs Averaging Time**

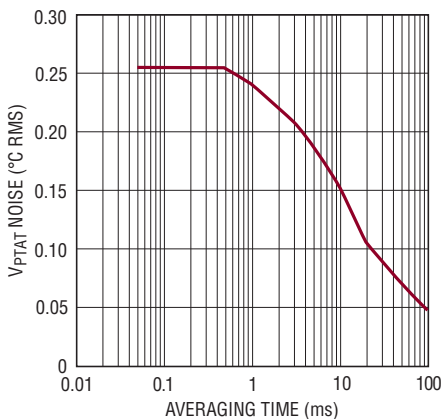

2997 G07

**UVLO vs Temperature  $V_{CC}$  Rising, Falling**

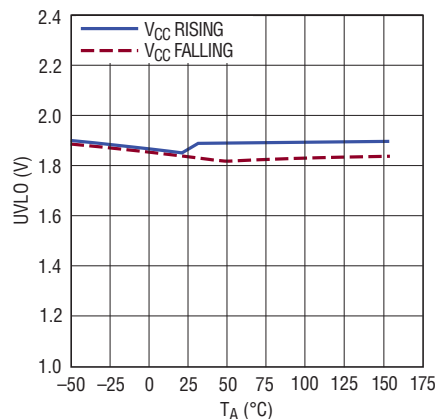

2997 G08

**Buffered Reference Voltage vs Temperature,  $V_{REF}$**

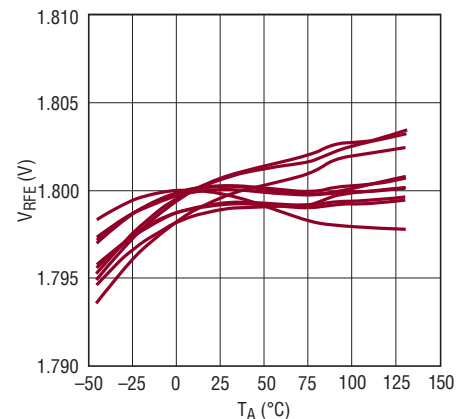

2997 G09

2997fa

**TYPICAL PERFORMANCE CHARACTERISTICS**

$T_A = 25^\circ\text{C}$ ,  $V_{CC} = 3.3\text{V}$  unless otherwise noted.

**Load Regulation of  $V_{REF}$  – Voltage vs Current**

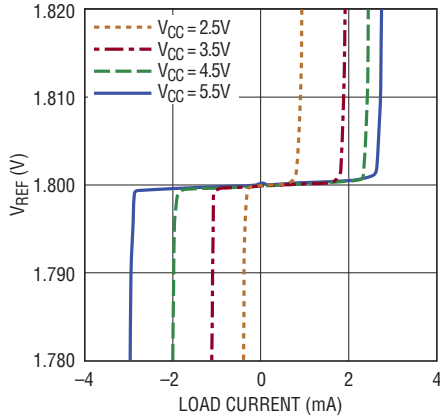

2997 G10

**Load Regulation of  $V_{PTAT}$  – Voltage vs Current**

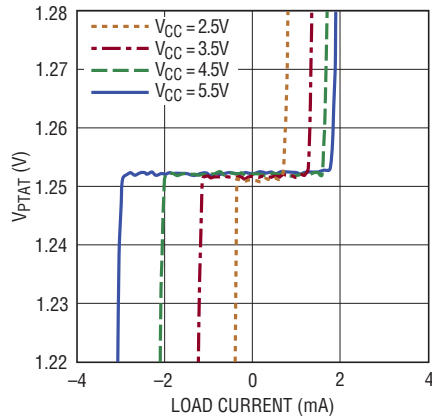

2997 G11

**Supply Current vs Temperature**

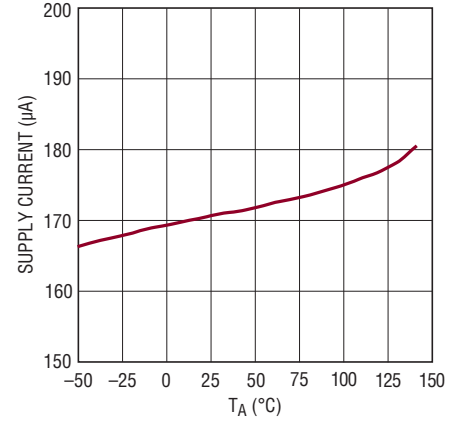

2997 G12

**LTC2997 Internal Sensor Thermal Step Response**

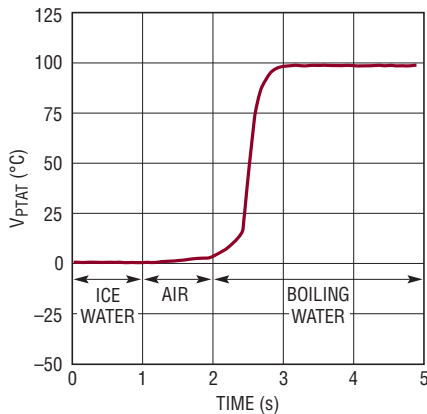

LTC2997 CONNECTED VIA 5 INCH 30AWG WRAPPING WIRES

2997 G13

**Remote Temperature Error vs Leakage Current at  $D^+$  with Remote Diode at  $25^\circ\text{C}$ ,  $T_{RMT}$**

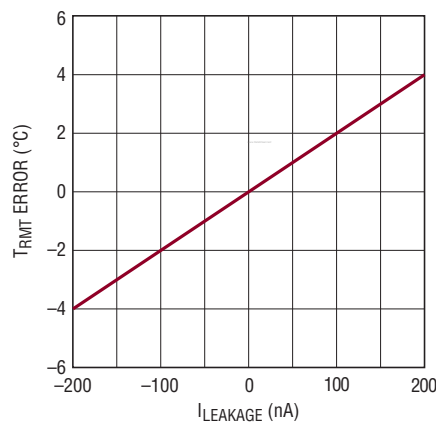

2997 G14

**Single Wire Remote Temperature Error vs Potential Difference Between Remote and Local Ground (VAC)**

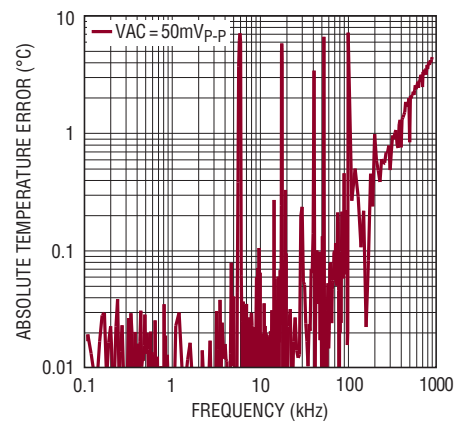

2997 G15

## PIN FUNCTIONS

**D<sup>+</sup>:** Diode Sense Current Source. D<sup>+</sup> sources the remote diode sensing current. Connect D<sup>+</sup> to the anode of the remote sensor device. It is recommended to connect a 470pF bypass capacitor between D<sup>+</sup> and D<sup>-</sup>. Larger capacitors may cause settling time errors (see Typical Performance Characteristics). If D<sup>+</sup> is tied to V<sub>CC</sub>, the LTC2997 measures the internal sensor temperature. Tie D<sup>+</sup> to V<sub>CC</sub> if unused.

**D<sup>-</sup>:** Diode Sense Current Sink. Connect D<sup>-</sup> to the cathode of the remote sensor device. Tie D<sup>-</sup> to GND for single wire remote sensing (see Typical Applications) or internal temperature sensing.

**GND:** Device Ground.

**V<sub>CC</sub>:** Supply Voltage. Bypass this pin to GND with a 0.1μF (or greater) capacitor. V<sub>CC</sub> operating range is 2.5V to 5.5V.

**V<sub>PTAT</sub>:** V<sub>PTAT</sub> Voltage Output. The voltage on this pin is proportional to the sensor's absolute temperature. V<sub>PTAT</sub> can drive a capacitive load of up to 1000pF. For larger load capacitance, insert 1kΩ between V<sub>PTAT</sub> and load to guarantee stability. V<sub>PTAT</sub> can drive up to ±200μA of load current. V<sub>PTAT</sub> is pulled low when the supply voltage goes below the under voltage lockout threshold.

**V<sub>REF</sub>:** Voltage Reference Output. V<sub>REF</sub> provides a 1.8V reference voltage. V<sub>REF</sub> can drive a capacitive load of up to 1000pF. For larger load capacitance, insert 1kΩ between V<sub>REF</sub> and load to guarantee stability. V<sub>REF</sub> can drive up to ±200μA of load current. Leave V<sub>REF</sub> open if unused.

**Exposed Pad:** Exposed pad may be left open or soldered to GND for better thermal coupling.

# BLOCK DIAGRAM

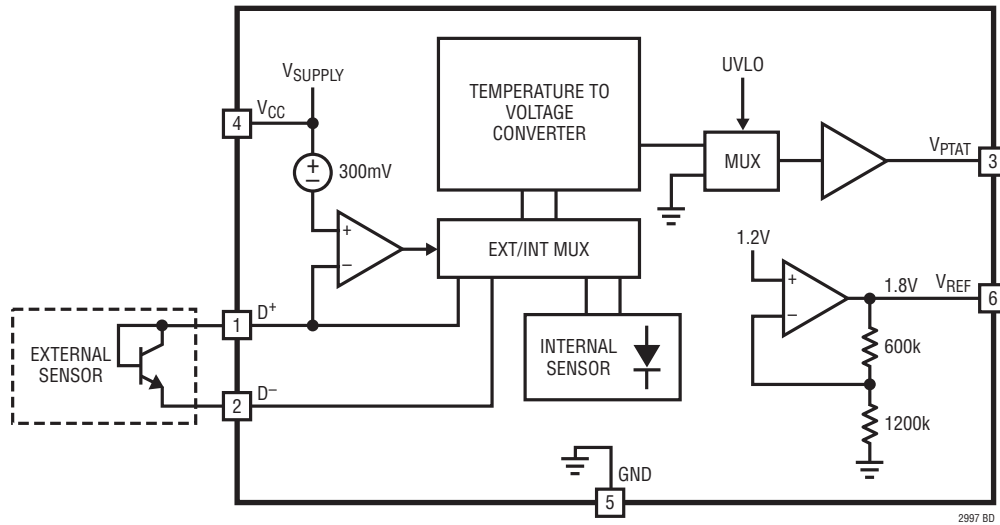

## OPERATION

The Block Diagram shows the main components of the LTC2997.

The LTC2997 measures temperature using either a remote or internal diode and provides a buffered voltage proportional to absolute temperature ( $V_{PTAT}$ ) and a buffered 1.8V reference voltage. Remote temperature measurements usually use a diode connected transistor as a temperature sensor, allowing the remote sensor to be a discrete NPN (ex. MMBT3904) or an embedded PNP device in a microprocessor or FPGA.

Temperature measurements are conducted by measuring the diode voltage at multiple test currents. The diode equation can be solved for T, where T is degrees Kelvin,  $I_S$  is a process dependent factor on the order of  $10^{-13}A$ ,  $\eta$  is the diode ideality factor, k is the Boltzmann constant and q is the electron charge:

$$T = \frac{q}{\eta \cdot k} \cdot \frac{V_{DIODE}}{\ln\left(\frac{I_D}{I_S}\right)}$$

This equation has a relationship between temperature and voltage, dependent on the process-dependent variable  $I_S$ . Measuring the same diode (with the same value  $I_S$ ) at two different currents yields an expression which is independent

of  $I_S$ . The value in the natural logarithm term becomes the ratio of the two currents, which is process independent.

$$T = \frac{q}{\eta \cdot k} \cdot \frac{V_{DIODE2} - V_{DIODE1}}{\ln\left(\frac{I_{D2}}{I_{D1}}\right)}$$

### Series Resistance Cancellation

Resistance in series with the remote diode causes a positive temperature error by increasing the measured voltage at each test current. The composite voltage equals:

$$V_{DIODE} + V_{ERROR} = \eta \frac{kT}{q} \cdot \ln\left(\frac{I_D}{I_S}\right) + R_S \cdot I_D$$

where  $R_S$  is the series resistance.

The LTC2997 removes this error term from the sensor signal by subtracting a cancellation voltage (see Figure 1). A resistance extraction circuit uses one additional current ( $I_3$ ) to determine the series resistance in the measurement path. Once the correct value of the resistor is determined  $V_{CANCEL}$  equals  $V_{ERROR}$ . Now the temperature to voltage converter's input signal is free from errors due to series resistance and the sensor temperature can be determined using currents  $I_1$  and  $I_2$ .

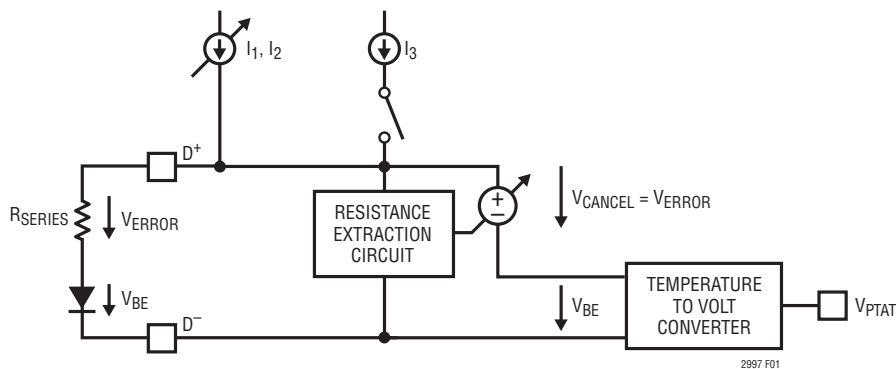

Figure 1. Series Resistance Cancellation



## APPLICATIONS INFORMATION

### Power Up and UVLO

The basic LTC2997 application using an external NPN transistor is shown in Figure 2.

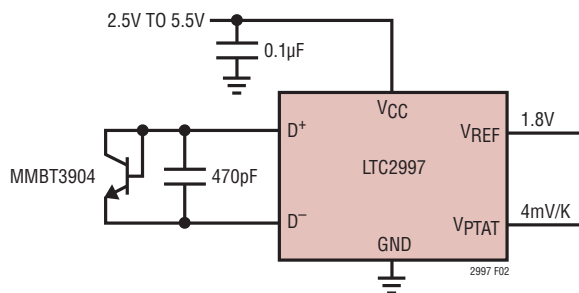

Figure 2. Basic Application Circuit

The  $V_{CC}$  pin must exceed the undervoltage threshold of 1.9V (typical) for normal operation. For  $V_{CC}$  below UVLO the LTC2997 enters power-on reset and  $V_{PTAT}$  is pulled low.

### Temperature Measurements

Before each conversion a voltage comparator connected to  $D^+$  automatically sets the LTC2997 into external or internal mode. Tying  $D^+$  to  $V_{CC}$  enables internal mode and  $V_{PTAT}$  represents the die temperature. The  $V_{PTAT}$  gain,  $K_T$ , is 4mV/K. The temperature in Kelvin is easily calculated:

$$T_{\text{KELVIN}} = \frac{V_{\text{PTAT}}}{K_T}$$

For  $V_{D^+}$  more than 300mV below  $V_{CC}$  (typical) the LTC2997 assumes that an external sensor is connected and will start sending sensing currents to the remote sensor diode. The anode of the external sensor must be connected to pin  $D^+$ . The cathode should be connected to  $D^-$  for best external noise immunity. For single wire measurements the sensor cathode is connected to remote GND and  $D^-$  must be connected to local GND (see Figure 7). Small ground DC voltages ( $<\pm 200\text{mV}$ ) between the two cathode potentials do not impact the measurement accuracy. AC voltages at odd multiples of 6kHz ( $\pm 20\%$ ) cause temperature measurement errors (see Typical Performance Characteristics). The LTC2997 is calibrated to yield a  $V_{PTAT}$  gain of 4mV/K for a remote diode with an ideality factor of 1.004. A built-in algorithm cancels errors due to series resistance

of up to 100 $\Omega$  to an error smaller than 1 $^{\circ}\text{C}$  (see Typical Performance Characteristics). The LTC2997 continuously measures the sensor diode at different test currents and updates  $V_{PTAT}$  every 3.5ms (typical).

### Input Noise Filtering

The change in sensor voltage per  $^{\circ}\text{C}$  is hundreds of microvolts, so electrical noise must be kept to a minimum. Bypass  $D^+$  and  $D^-$  with a 470pF capacitor close to the LTC2997 to suppress external noise. Bypass capacitors greater 1nF cause settling time errors of the different measurement currents. See Typical Performance Characteristics. Long wires connecting external sensors add series resistance, mutual capacitance between  $D^+$  and  $D^-$ , and cause leakage currents. A 10m CAT6 cable has  $\sim 500\text{pF}$  of mutual capacitance and adds negligible series resistance and leakage currents. Recommended shielding and PCB trace considerations for best noise immunity are illustrated in Figure 3.

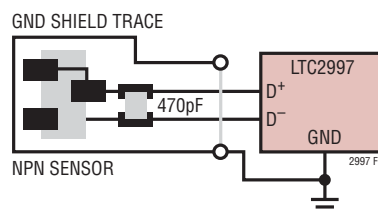

Figure 3. Recommended PCB Layout

### Output Noise Filtering

The  $V_{PTAT}$  output typically exhibits 1mVRMS (0.25 $^{\circ}\text{C}$  RMS) noise. For applications which require lower noise digital or analog averaging can be applied to the output. Choose the averaging time according to the following equation:

$$t_{\text{AVG}} = \left( \frac{0.015 [^{\circ}\text{C}/\sqrt{\text{Hz}}]}{T_{\text{NOISE}}} \right)^2$$

where  $t_{\text{AVG}}$  is the averaging time and  $T_{\text{NOISE}}$  the desired temperature noise in  $^{\circ}\text{C}$  RMS. For example, if the desired noise performance is 0.015 $^{\circ}\text{C}$  RMS, set the averaging time to one second. See Typical Performance Characteristics.

## APPLICATIONS INFORMATION

### Choosing a Sensor

The LTC2997 is factory calibrated for an ideality factor of 1.004, which is typical of the popular MMBT3904 NPN transistor. Semiconductor purity and wafer-level processing intrinsically limit device-to-device variation, making these devices interchangeable between most manufacturers with a temperature error of typically less than 0.5°C. Some recommended sources are listed in Table 1:

**Table 1. Recommended Transistors for Use as Temperature Sensors.**

MANUFACTURER	PART NUMBER	PACKAGE
Fairchild Semiconductor	MMBT3904	SOT-23
Central Semiconductor	CMPT3904	SOT-23
Diodes, Inc.	MMBT3904	SOT-23
On Semiconductor	MMBT3904LT1	SOT-23
NXP	MMBT3904	SOT-23
Infineon	MMBT3904	SOT-23
Rohm	UMT3904	SC-70

Discrete two terminal diodes usually have ideality factors significantly higher than 1.004 and are therefore not recommended as remote sensing devices.

### Protection

The LTC2997 can withstand up to ±4kV of electrostatic discharge (ESD, human body). ESD beyond this voltage can damage or degrade the device including lowering the remote sensor measurement accuracy due to increased leakage currents on D<sup>+</sup> and D<sup>-</sup>.

To protect the sensing inputs against larger ESD strikes, external protection can be added using TVS diodes to ground (Figure 4). Care must be taken to choose diodes with low capacitance and low leakage currents in order not to degrade the external sensor measurement accuracy (see Typical Performance Characteristics).

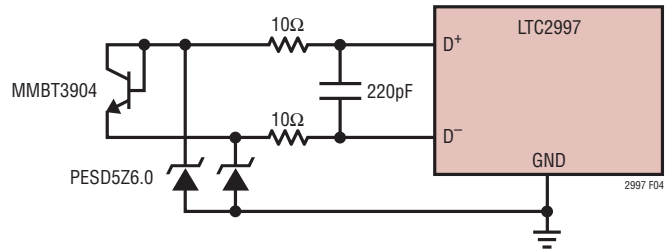

**Figure 4. Increasing ESD Robustness with TVS Diodes**

### Ideality Factor Scaling

While an ideality factor value of 1.004 is typical of many sensor devices, small deviations can yield significant temperature errors. The ideality factor acts as a temperature scaling factor. The temperature error for a 1% deviation is 1% of the Kelvin temperature. Thus, at 25°C (298K) a +1% accurate ideality factor error yields a +2.98 degree error. At 85°C (358K) a +1% error yields a 3.58 degree error. It is possible to scale the PTAT voltage if an external sensor with an ideality factor other than 1.004 is used. The scaling equation for the compensated PTAT voltage is listed below.

LTC2997 Ideality Calibration Value:

$$\eta_{\text{CAL}} = 1.004$$

Actual Remote Sensor Ideality Value:

$$\eta_{\text{ACT}}$$

Compensated PTAT Voltage:

$$V_{\text{PTAT\_COMP}} = \frac{\eta_{\text{CAL}}}{\eta_{\text{ACT}}} \cdot V_{\text{PTAT\_MEAS}}$$

Compensated Kelvin Temperature:

$$T_{\text{KELVIN\_COMP}} = \frac{\eta_{\text{CAL}}}{\eta_{\text{ACT}}} \cdot T_{\text{KELVIN\_MEAS}}$$

Compensated Celsius Temperature:

$$T_{\text{CELSIUS\_COMP}} = \frac{\eta_{\text{CAL}}}{\eta_{\text{ACT}}} \cdot (T_{\text{KELVIN\_MEAS}}) - 273.15$$

## TYPICAL APPLICATIONS

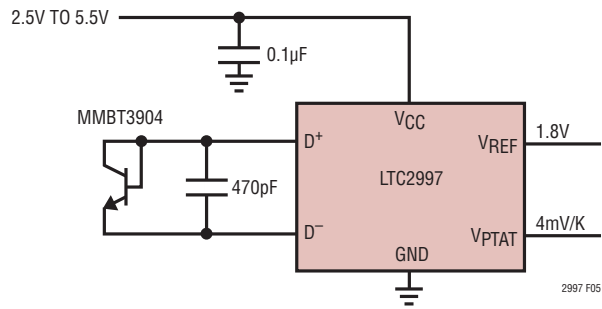

Figure 5. Single Remote Temperature Sensor

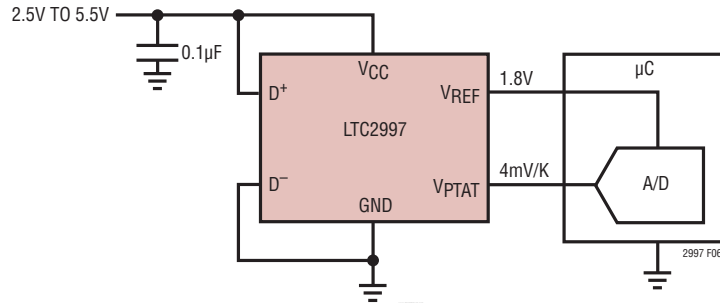

Figure 6. Internal Temperature Sensor

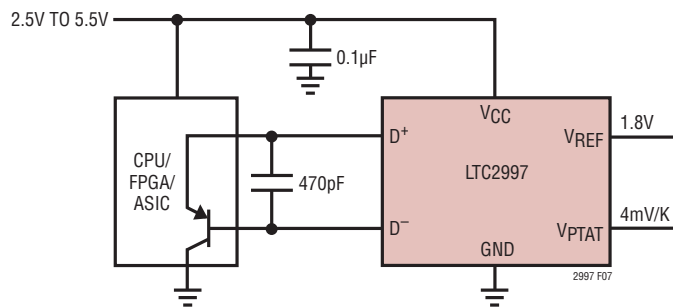

Figure 7. Remote CPU Temperature Sensor

TYPICAL APPLICATIONS

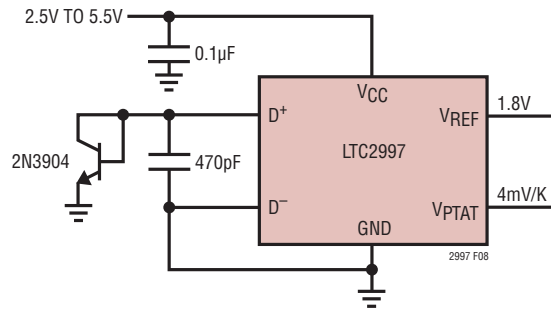

Figure 8. Single Wire Remote Temperature Sensor

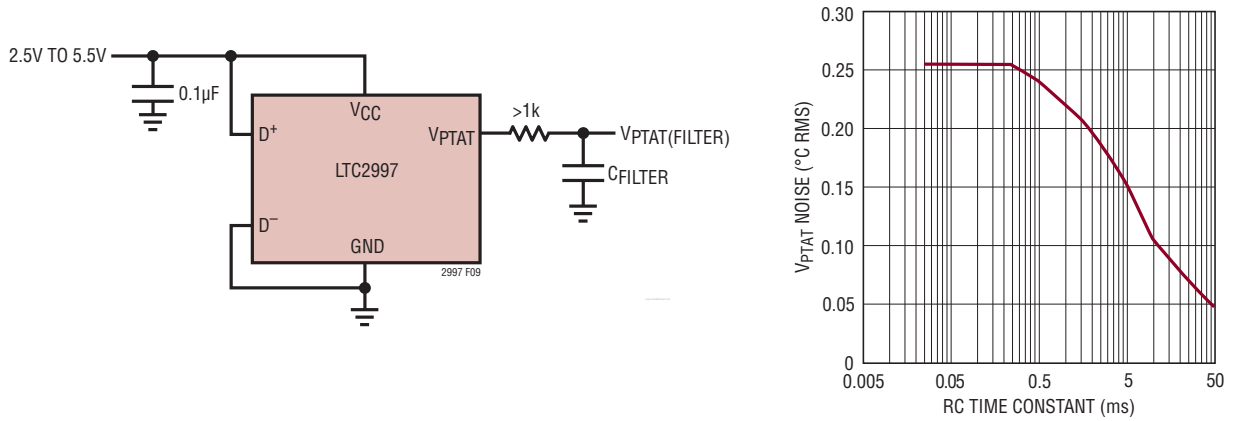

Figure 9. Output Noise Filter

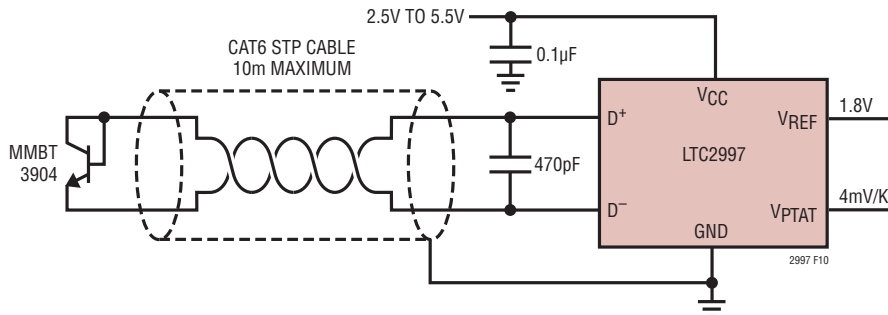

Figure 10. Long Distance Remote Temperature Sensor

TYPICAL APPLICATIONS

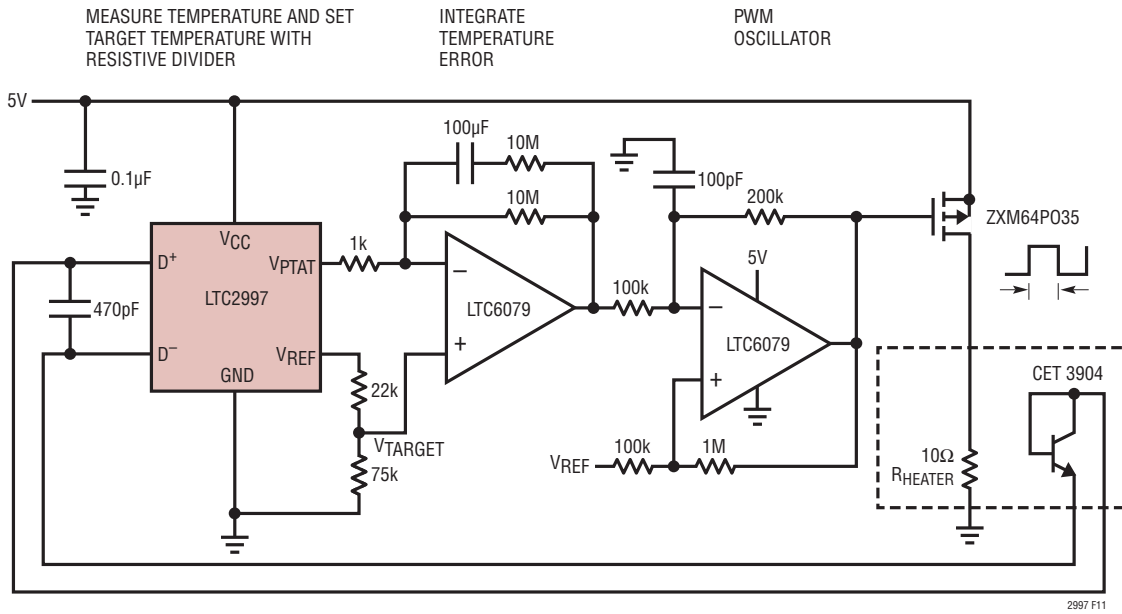

Figure 11. Analog PWM Heater Controller

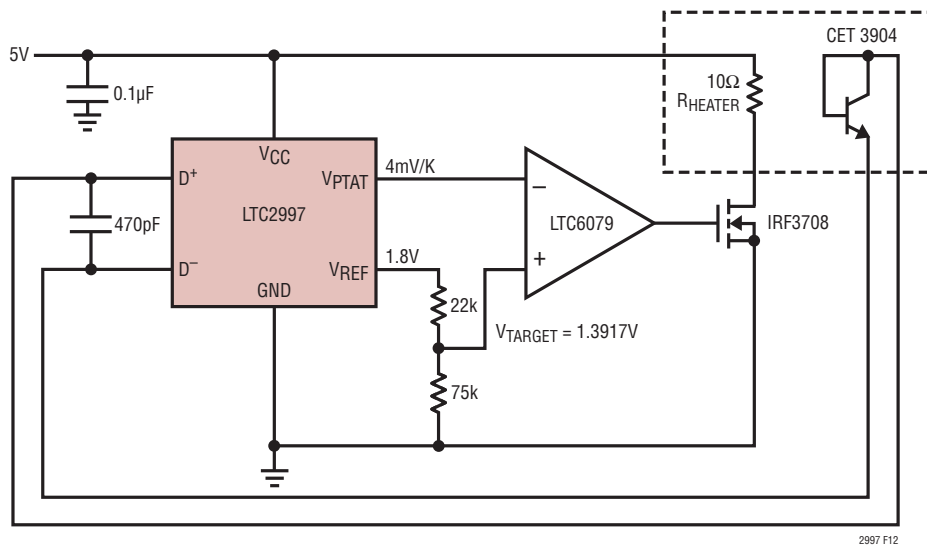

Figure 12. 75°C Analog Heater Controller

TYPICAL APPLICATIONS

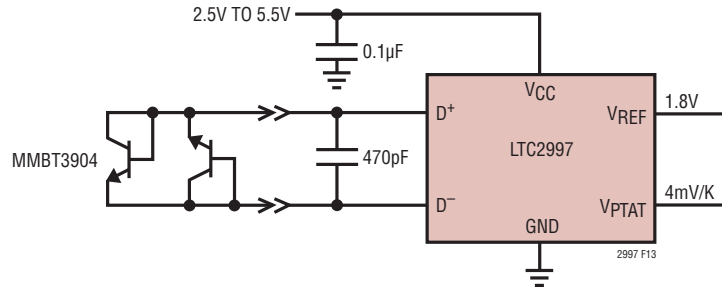

Figure 13. Remote Diode Sensor Insensitive to Cable Connection Polarity

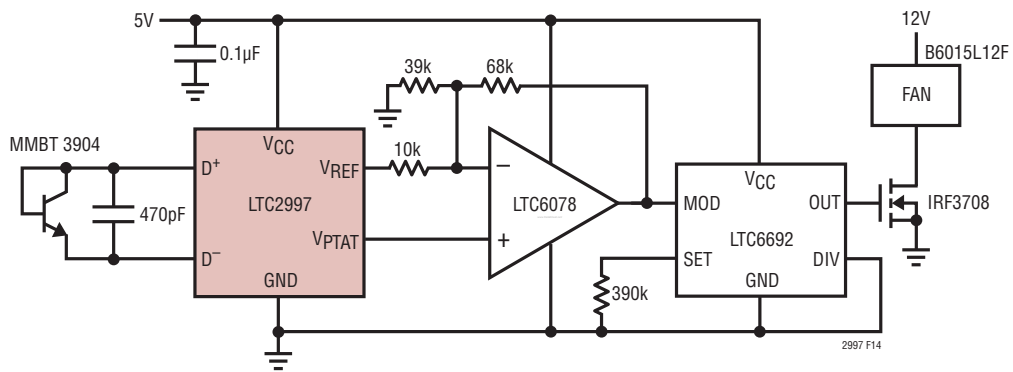

Figure 14. Temperature Proportional PWM Fan Speed Controller

TYPICAL APPLICATIONS

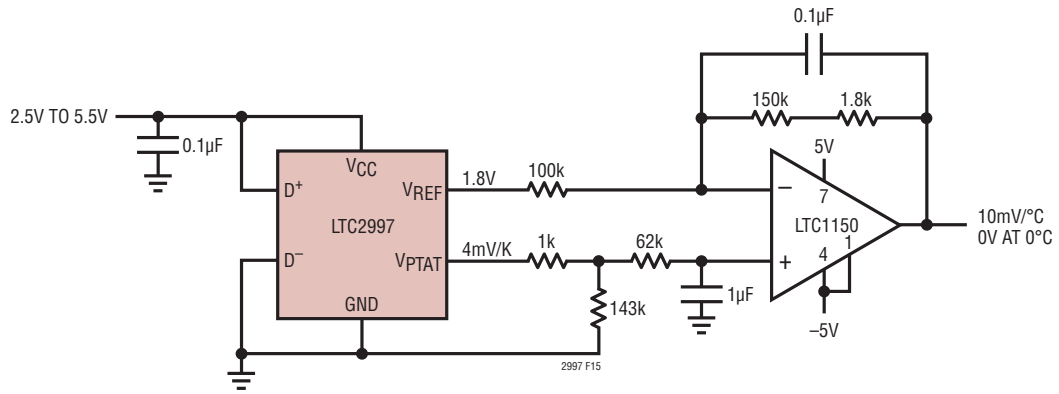

Figure 15. Celsius Thermometer

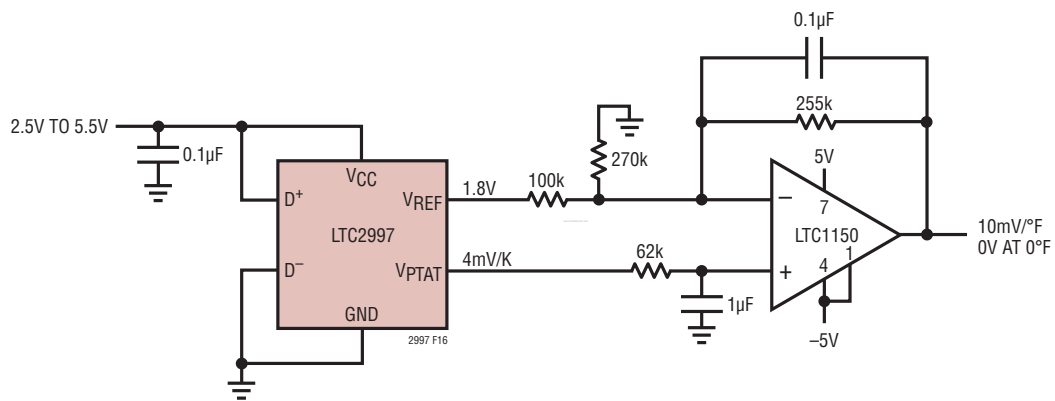
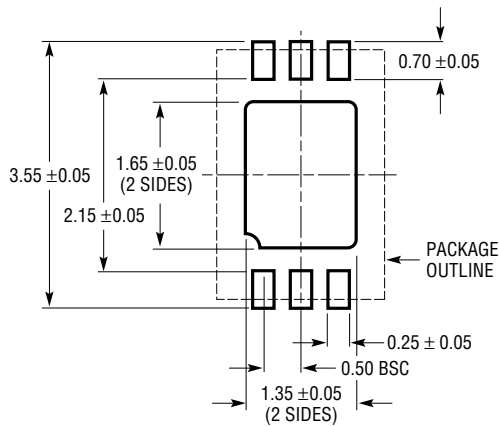

Figure 16. Fahrenheit Thermometer

# PACKAGE DESCRIPTION

Please refer to <http://www.linear.com/designtools/packaging/> for the most recent package drawings.

**DCB Package**  
**6-Lead Plastic DFN (2mm × 3mm)**  
 (Reference LTC DWG # 05-08-1715 Rev A)



RECOMMENDED SOLDER PAD PITCH AND DIMENSIONS

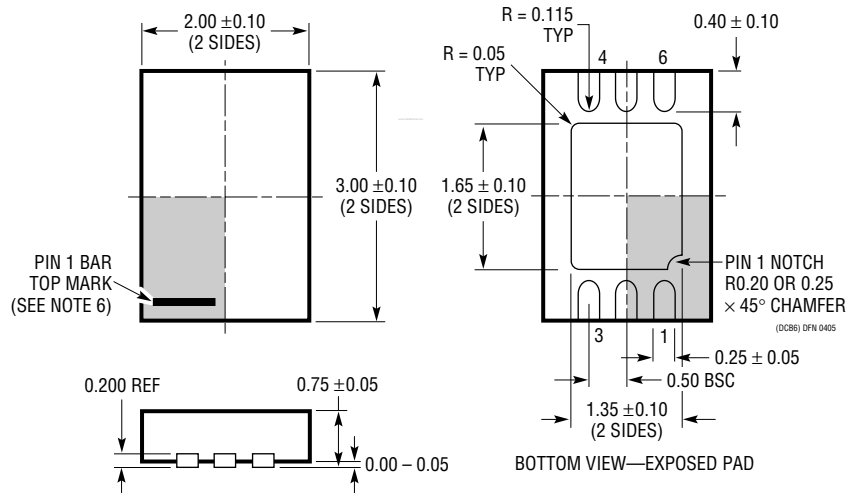

**NOTE:**

1. DRAWING TO BE MADE A JEDEC PACKAGE OUTLINE M0-229 VARIATION OF (TBD)
2. DRAWING NOT TO SCALE
3. ALL DIMENSIONS ARE IN MILLIMETERS
4. DIMENSIONS OF EXPOSED PAD ON BOTTOM OF PACKAGE DO NOT INCLUDE MOLD FLASH. MOLD FLASH, IF PRESENT, SHALL NOT EXCEED 0.15mm ON ANY SIDE
5. EXPOSED PAD SHALL BE SOLDER PLATED
6. SHADED AREA IS ONLY A REFERENCE FOR PIN 1 LOCATION ON THE TOP AND BOTTOM OF PACKAGE



## REVISION HISTORY

REV	DATE	DESCRIPTION	PAGE NUMBER
A	9/11	Changed 4mV/°C to 4mV/°K in Features	1
		Updated Description	1
		Updated Electrical Characteristics	3
		Added Graph G15	5
		Updated Pin Functions	6
		Updated Applications Information	9, 10
		Updated Figures 9, 10, 13, 15, 16	12, 14, 15
		Updated Related Parts	18

## TYPICAL APPLICATION

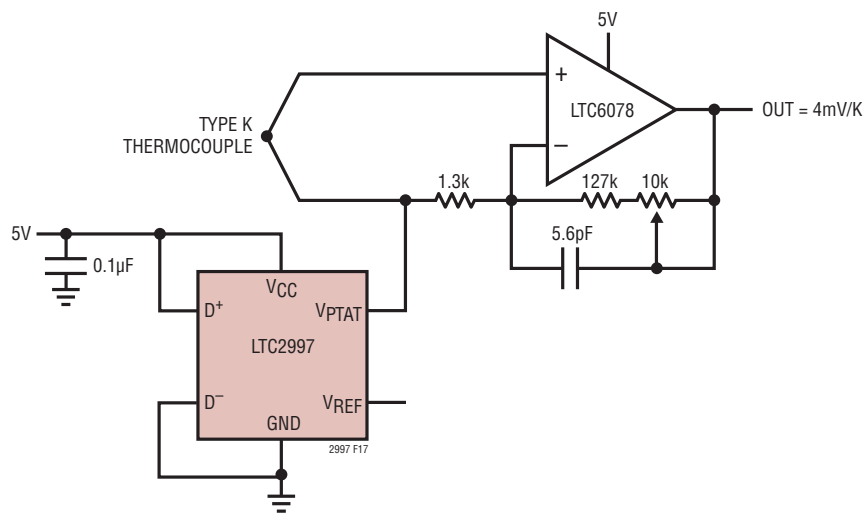

Figure 17. Thermocouple Thermometer with Cold Junction Compensation

## RELATED PARTS

PART NUMBER	DESCRIPTION	COMMENTS
LTC2990	Remote/Internal Temperature, Voltage and Current Monitor	Measures Two Remote Diode Temperatures, $\pm 1^\circ\text{C}$ Accuracy, $0.06^\circ\text{C}$ Resolution, $\pm 2^\circ\text{C}$ Internal Temperature Sensor, $I^2C$ Interface,
LTC2909	Precision Triple/Dual Input UV, OV and Negative Voltage Monitor	Two Adjustable Inputs, $\pm 1.5\%$ Accuracy, 6.5V Shunt Regulator
LTC2919	Precision Triple/Dual Input UV, OV and Negative Voltage Monitor	Two Adjustable Inputs, $\pm 1.5\%$ Accuracy, 6.5V Shunt Regulator, Open-Drain/RST, OUT1 and OUT2 Outputs
LTC6078	LTC6078 Micropower Precision, Dual/Quad CMOS Rail-to-Rail Input/Output Amplifiers	Maximum Offset Voltage of $25\mu\text{V}$ ( $25^\circ\text{C}$ ), Maximum Offset Drift of $0.7\mu\text{V}/^\circ\text{C}$ , Maximum Input Bias of $1\text{pA}$ ( $25^\circ\text{C}$ ) to $50\text{pA}$ ( $\leq 85^\circ\text{C}$ )
LTC6079	Micropower Precision, Dual/Quad CMOS Rail-to-Rail Input/Output Amplifiers	Maximum Offset Voltage of $25\mu\text{V}$ ( $25^\circ\text{C}$ ), Maximum Offset Drift of $0.7\mu\text{V}/^\circ\text{C}$ , Maximum Input Bias of $1\text{pA}$ ( $25^\circ\text{C}$ ) to $50\text{pA}$ ( $\leq 85^\circ\text{C}$ )