



**Product Features:**

Surface Mount Package  
 Reflow Compatible  
 Compatible with Leadfree Processing

**Applications:**

Test Equipment  
 Server & Storage  
 Sonet /SDH

<b>Frequency</b>	1 MHz to 750.000 MHz
<b>Output Level</b> LVDS LVPECL	Vod = 393 mV Typ., 475 mV Max. '0' = Vcc - 1.63 V Max. '1' = Vcc - 1.02 V Min.
<b>Duty Cycle</b>	Specify 50% ±10% or ±5% See Table in Part Number Guide
<b>Rise / Fall Time</b>	0.6 nS Max.
<b>Output Load</b> LVDS LVPECL	100 Ω Differential 50 Ω to Vcc - 2.0 VDC
<b>Frequency Stability</b>	See Frequency Stability Table in Part Numbering Guide (Includes room temperature tolerance and stability over operating temperature)
<b>Start-up Time</b>	10 mS Max.
<b>Enable / Disable Time</b>	100 nS Max.
<b>Supply Voltage</b>	See Input Voltage Table, tolerance ±5 %
<b>Current</b>	LVDS = 90 mA Max., *** LVPECL = 130 mA Max. ***
<b>Operating</b>	See Operating Temperature Table in Part Number Guide
<b>Storage</b>	-55° C to +125° C

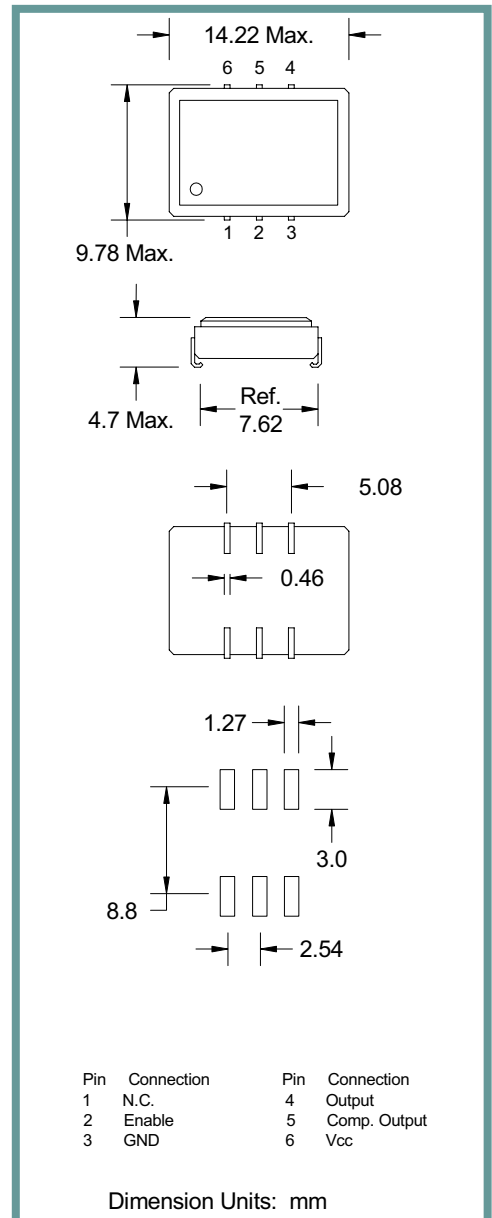

Part Number Guide		Sample Part Number: ISM68 - 3169BH - 156.250					
Package	Input Voltage	Operating Temperature	Symmetry (Duty Cycle)	Output	Stability (in ppm)	Enable / Disable	Frequency
ISM68 -	3 = 3.3 V	1 = 0° C to +70° C	5 = 45 / 55 Max.	8 = LVDS	**A = ±25	H = Enable	- 156.250 MHz
	7 = 3.0 V	6 = -10° C to +70° C	6 = 40 / 60 Max.	9 = LVPECL	B = ±50		
	2 = 2.7 V	3 = -20° C to +70° C			C = ±100		
	6 = 2.5 V	4 = -30° C to +75° C					
		2 = -40° C to +85° C					

NOTE: A 0.01 µF bypass capacitor is recommended between Vcc (pin 6) and GND (pin 3) to minimize power supply noise.

\*\* Not available for all temperature ranges. \*\*\* Frequency, supply, and load related parameters.



9mm x 14 mm Ceramic Package SMD Oscillator, LVPECL / LVDS



ISM68 Series

**Pb Free Solder Reflow Profile:**

**Typical Application:**

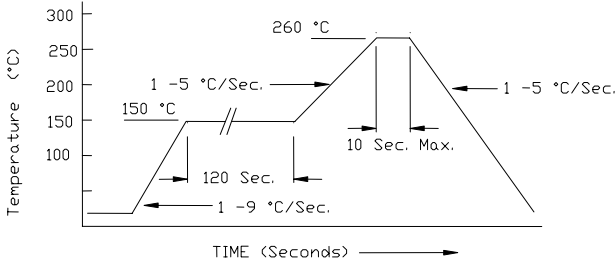

\*Units are backward compatible with 240C reflow processes

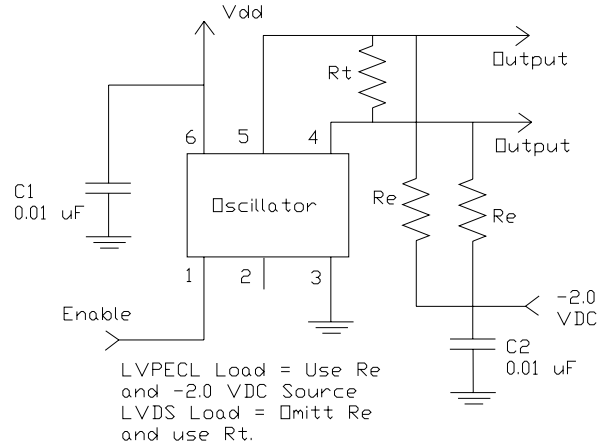

**Package Information:**

MSL = N.A. (package does not contain plastic, storage life is unlimited under normal room conditions).  
 Termination = e4 (Au over Ni over W base metalization).

**Tape and Reel Information:**

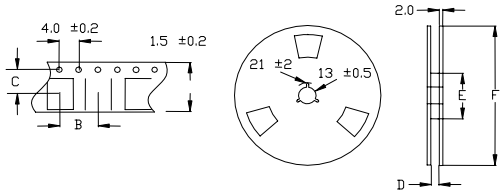

Quantity per Reel	1000
A	24 +/- .3
B	12 +/- .2
C	11.5 +/- .2
D	25 +/- 1.5
E	80 / 100
F	330

**Environmental Specifications**

Thermal Shock	MIL-STD-883, Method 1011, Condition A
Moisture Resistance	MIL-STD-883, Method 1004
Mechanical Shock	MIL-STD-883, Method 2002, Condition B
Mechanical Vibration	MIL-STD-883, Method 2007, Condition A
Resistance to Soldering Heat	J-STD-020C, Table 5-2 Pb-free devices (except 2 cycles max)
Hazardous Substance	Pb-Free / RoHS / Green Compliant
Solderability	JESD22-B102-D Method 2 (Preconditioning E)
Terminal Strength	MIL-STD-883, Method 2004, Test Condition D
Gross Leak	MIL-STD-883, Method 1014, Condition C
Fine Leak	MIL-STD-883, Method 1014, Condition A2, R1=2x10 <sup>-8</sup> atm cc/s
Solvent Resistance	MIL-STD-202, Method 215

**Marking**

Line 1: ILSI and Date Code (YWW)  
 Line 2: Frequency