

Product Features:

Small Surface Mount Package
 CMOS/TTL Compatible Logic Levels
 Compatible with Leadfree Processing

Applications:

SD/HD Video
 Sonet /SDH
 VoIP
 T1/E1, T3/E3
 Wireless Base Station

Frequency	1.000 MHz to 77.760 MHz (Fund.)
Output Level (HCMOS)	V _{OH} = 90% VDD Min. V _{OL} = 10% VDD Max.
Duty Cycle	50% ±10% Std.(5% optional)
Rise / Fall Time	1.0 MHz to 20.0 MHz : 10.0 nS Max. 20.1 MHz to 40.0 MHz : 8.0 nS Max. 40.0 MHz to 77.76 MHz : 5.0 nS Max.
Output Load	15pF
Frequency Stability	See Table Below
Start-up Time	10 mS Max.
Supply Voltage	See Input Voltage Table, tolerance ±5 %
Control Voltage	1.25 VDC ±1.05 VDC for 2.5 VDC, 1.65 VDC ±1.35 VDC for 3.3 VDC, 2.5 VDC ±2.0 VDC for 5.0 VDC
Pull Range	±100 ppm min. (Std). See Table Below.
Current	1.0 MHz to 20.0 MHz : 10.0 mA Max. 20.1 MHz to 40.0 MHz : 15.0 mA Max.(2.5V/3.3V) 20.1 MHz to 40.0 MHz : 20.0 mA Max.(5.0V) 40.0 MHz to 77.76 MHz : 25.0 mA Max.(2.5V/3.3V) 40.0 MHz to 77.76 MHz : 30.0 mA Max.(5.0V)
Enable/Disable(Pin 2 or Pin 5)	70% VDD Min. / 30%VDD Max.
Linearity	10%
Aging	±5ppm/year Max. (±3ppm optional)
Phase Jitter (12kHz to 20kHz)	1.0 pS Max.
Period Jitter (PK-PK)	100pS Max.
Temperature Operating Storage	See Below -55° C to +125° C

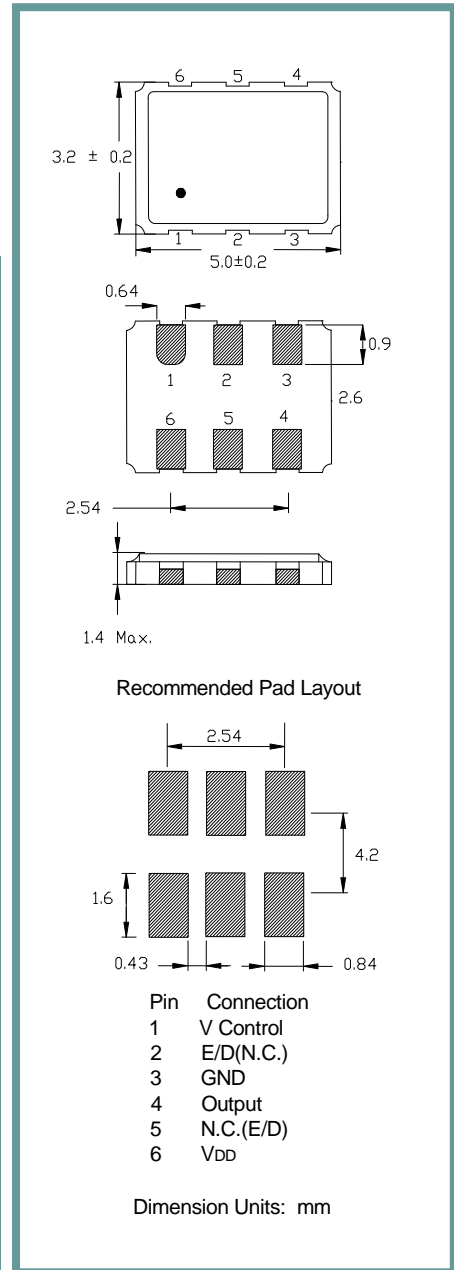

Part Number Guide		Sample Part Number: I603-1BC3H2-20.000				
Package	Operating Temperature	Stability (in ppm)	Pullability	Supply Voltage	Enable / Disable	Frequency
I603 -	1 = 0° C to +70° C	F = ±20	B = ±50 PPM Min.	5 = 5.0 VDC	H2 = Enable(pin 2)	- 20.000 MHz
	2 = -40° C to +85° C	A = ±25	C = ±100 PPM Min.*	3 = 3.3 VDC	H5 = Enable(pin 5)	
		B = ±50	K = ±150 PPM Min.*	6 = 2.5 VDC		

NOTE: A 0.01 µF bypass capacitor is recommended between Vcc (pin 6) and GND (pin 3) to minimize power supply noise. * Not available at all voltages.

Pb Free Solder Reflow Profile:

Typical Application:

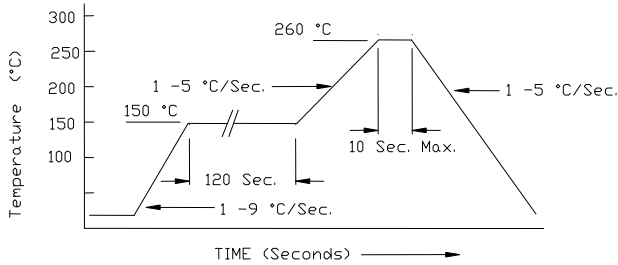

*Units are backward compatible with 240C reflow processes

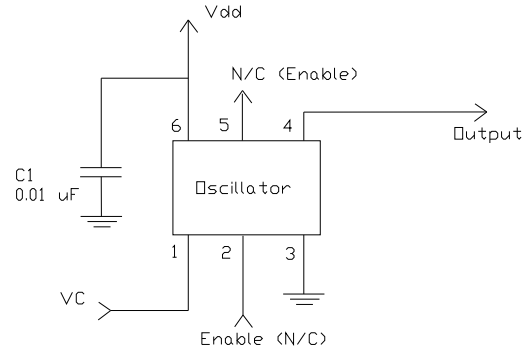

Package Information:

MSL = N.A. (package does not contain plastic, storage life is unlimited under normal room conditions).
Termination = e4 (Au over Ni over W base metalization).

Tape and Reel Information:

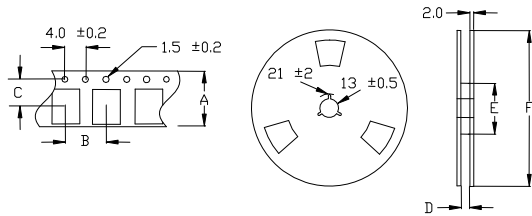

Quantity per Reel	1000
A	16 +/- .3
B	8 +/- .2
C	7.5 +/- .2
D	17.5 +/- .1
E	50 / 60 / 80
F	180 / 250

Environmental Specifications

Thermal Shock	MIL-STD-883, Method 1011, Condition A
Moisture Resistance	MIL-STD-883, Method 1004
Mechanical Shock	MIL-STD-883, Method 2002, Condition B
Mechanical Vibration	MIL-STD-883, Method 2007, Condition A
Resistance to Soldering Heat	J-STD-020C, Table 5-2 Pb-free devices (except 2 cycles max)
Hazardous Substance	Pb-Free / RoHS / Green Compliant
Solderability	JESD22-B102-D Method 2 (Preconditioning E)
Terminal Strength	MIL-STD-883, Method 2004, Test Condition D
Gross Leak	MIL-STD-883, Method 1014, Condition C
Fine Leak	MIL-STD-883, Method 1014, Condition A2, R1=2x10 ⁻⁸ atm cc/s
Solvent Resistance	MIL-STD-202, Method 215

Marking

Line 1: ILSI and Date Code
Line 2: Frequency