

Four-Channel High Voltage Protection T/R Switch

Features

- ▶ Up to $\pm 130\text{V}$ input voltage protection
- ▶ Low on resistance - 15Ω typical
- ▶ Fast switching speed
- ▶ Four electrically isolated channels
- ▶ No external supplies needed

Applications

- ▶ Medical ultrasound imaging
- ▶ NDT applications
- ▶ Fast resettable fuses
- ▶ High side switches
- ▶ Data acquisition

General Description

The Supertex MD0105 is a high voltage current limiting protection device. It is designed to protect a low noise receiver from the high voltage transmit pulses in ultrasound applications and is commonly referred to as a T/R (transmit and receive) switch.

The MD0105 can be considered as a normally closed switch with a typical switch resistance of 15Ω , allowing small signals to pass. Once the voltage drop across the two terminals exceeds a nominal value of $\pm 2.0\text{V}$, the device will start to turn off. In the off state, the MD0105 can withstand up to $\pm 130\text{V}$ across its terminals. A small amount of current, typically $200\mu\text{A}$, is allowed to flow through.

The MD0105 is not limited to just ultrasound applications. It can also be used for resettable fuses to protect power lines, output short circuit protection, and data acquisition. The MD0105 is available in an 18-Lead 5x5mm DFN package as a four-channel device.

Typical Application Circuit

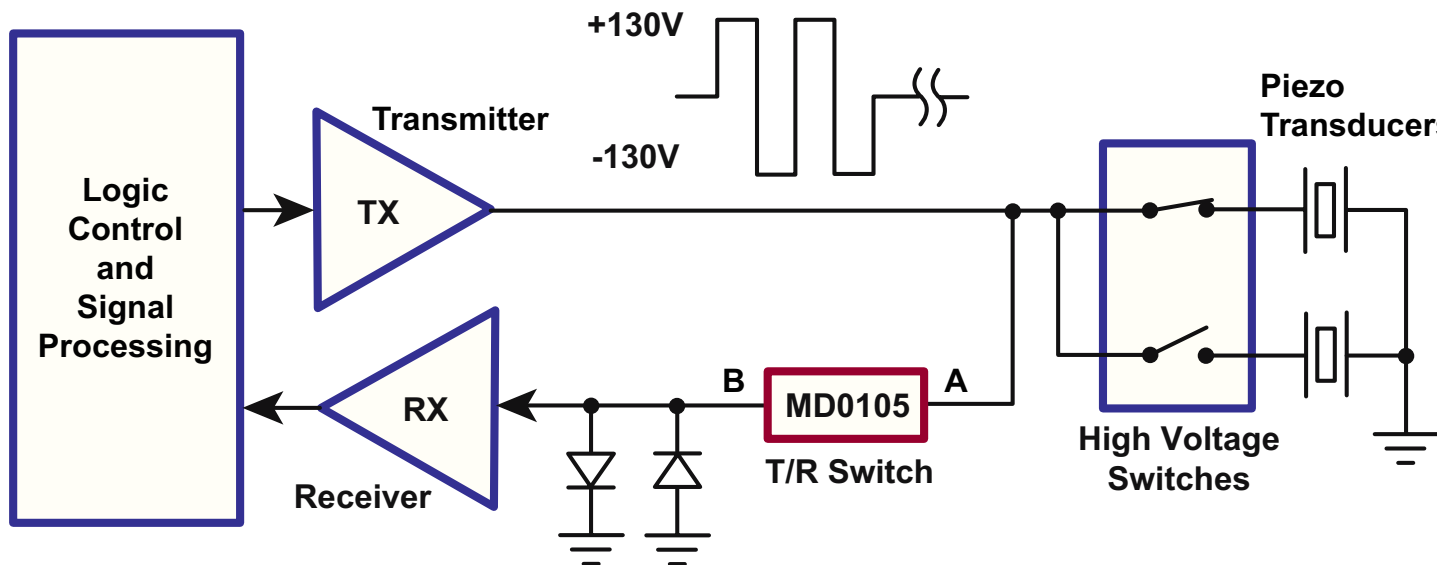

Ordering Information

Device	Package Option
	18-Lead DFN 5.00x5.00mm body 1.00mm height (max) 0.50mm pitch
MD0105	MD0105K6-G

-G indicates package is RoHS compliant ('Green')



ESD Sensitive Device

Pin Configurations

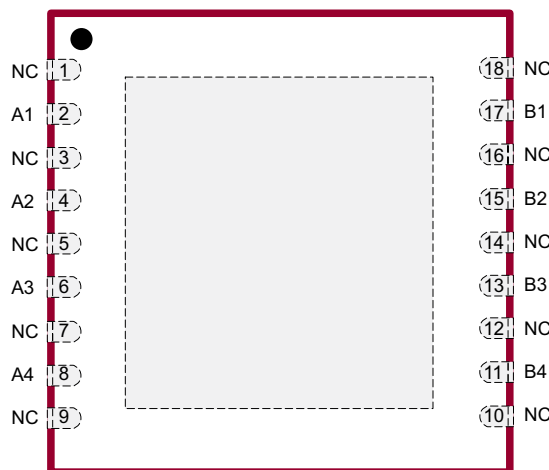

18-Lead DFN (K6)
 (top view)
 (Pads are at bottom of device)

Absolute Maximum Ratings¹

Parameter	Value
$V_A - V_B$, Differential voltage drop	0 to $\pm 140V$
Maximum junction temperature	+125°C
Storage temperature range	-65°C to 150°C
Power dissipation, 18-Lead DFN ²	1.6W

Notes:

1. Absolute Maximum Ratings are those values beyond which damage to the device may occur. Functional operation under these conditions is not implied. Continuous operation of the device at the absolute rating level may affect device reliability. All voltages are referenced to device ground.

2. Mounted on FR4 board, 25mm x 25mm x 1.57mm

Product Marking



L = Lot Number
 YY = Last Digit of Year Sealed
 WW = Code for Week Sealed
 A = Assembler ID
 C = Country of Origin
 — = "Green" Packaging

18-Lead DFN (K6)

Package may or may not include the following marks: Si or

Electrical Characteristics

($T_J = 25^\circ C$, unless otherwise specified)

Sym	Parameter	Min	Typ	Max	Units	Conditions
BV_{A-B}	Breakdown voltage from A to B or B to A	± 130	-	-	V	$I_{A-B} = \pm 1.0mA$
R_{SW}	Switch ON resistance from A to B or B to A	-	15	-	Ω	$I_{A-B} = \pm 5.0mA$
V_{TRIP}	V_{A-B} trip point to turn off	-	± 1.0	± 2.0	V	---
V_{OFF}	Switch turn off voltage	-	± 2.0	-	V	$I_{A-B} = \pm 1.0mA$
$I_{A-B(OFF)}$	Switch off current	-	± 200	± 300	μA	$V_{A-B} = \pm 130V$
I_{PEAK}	Peak switching current	-	± 60	-	mA	---
T_{OFF}	Turn off time	-	-	20	ns	---
T_{ON}	Turn on time	-	-	20	ns	---
$C_{SW(ON)}$	Switch ON capacitance from A to B or B to A	-	21	-	pF	SW = ON
$C_{SW(OFF)}$	Switch OFF capacitance from A to B or B to A	-	15	-	pF	$V_{SW} = 25V$
BW	Small signal bandwidth	-	100	-	MHz	$R_{LOAD} = 50\Omega$
T_J	Operating junction temperature	-40	-	+125	°C	---

Block Diagram

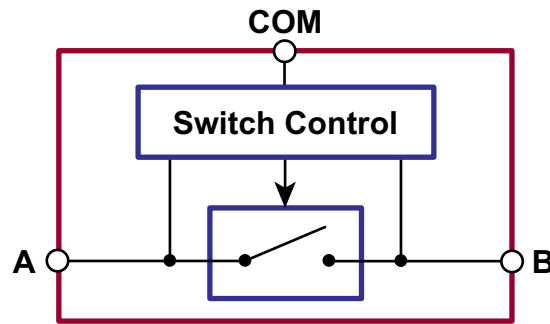

Typical I-V Characteristics

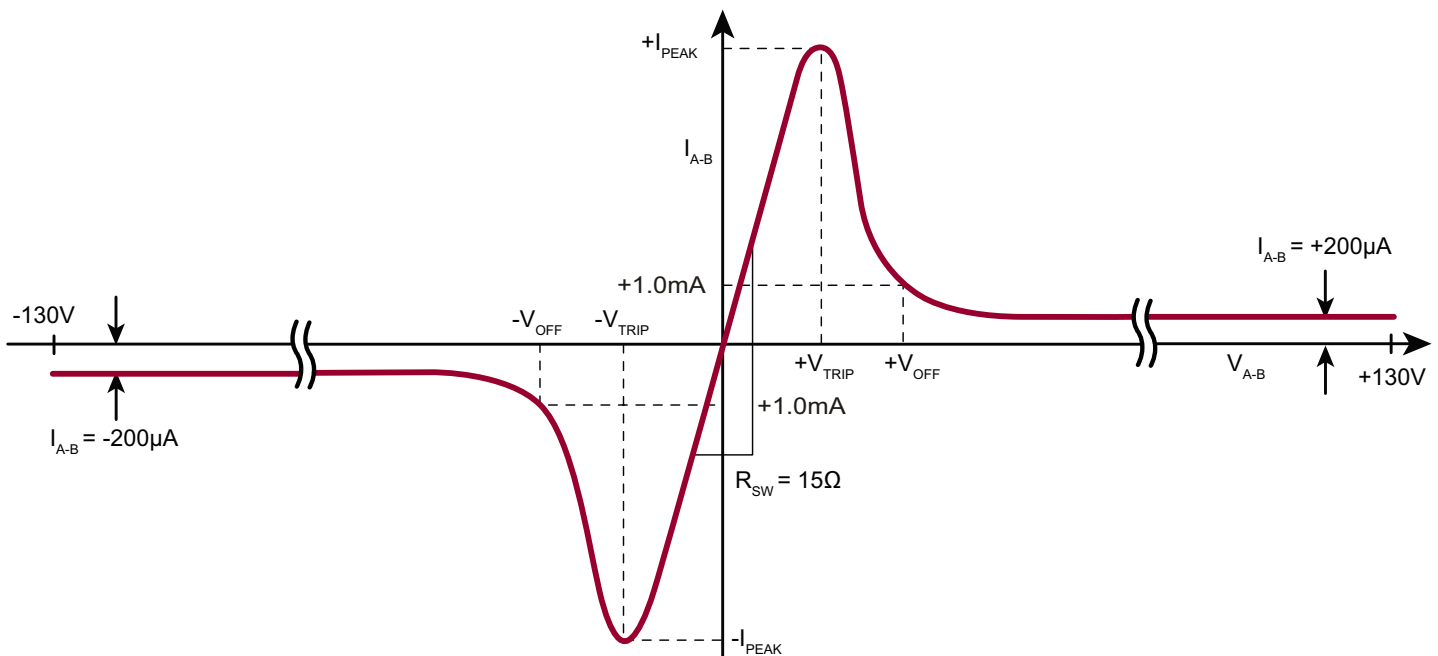

Functional Description

The Supertex MD0105 can be considered as a normally closed switch controlled by a switch control (please refer to the block diagram). The switch control monitors the voltage drop across terminals A and B. If the voltage difference is greater than $\pm 2.0V$, the T/R switch will start to open. Once in the open state, there is a small amount of current flowing through the T/R switch, $200\mu A$, to detect if the high voltage is still present or not.

The T/R switch will not close until the voltage across terminal A and B drops below $\pm 2.0V$. A pair of back-to-back diodes from the receive side of the switch to ground is needed to complete the circuit and to allow the initial peak current (about $60mA$) to flow through the switch so it can drop $\pm 2.0V$. If the diodes are not present, then there is no current path

and the voltage drop across terminal A and B will be less than $\pm 2.0V$, so the switch will remain in the closed position.

The MD0105 does not require any power supply. There are only two active pins; one connects to the transmitter side, one connects to the receiver side.

On Resistance

When the voltage across terminals A and B are below $\pm 2.0V$, the switch is in the receive mode and the R_{ON} is typically 15Ω . Once the voltage across the terminals A and B is greater than $\pm 2.0V$, the switch is in the transmit mode and blocking the high voltage pulses from passing through to the receiver and damaging it.

Switch Capacitance

The typical switch On capacitance ($C_{SW(ON)}$) is 21pF. This is measured from A to B when the switch is ON. The switch OFF capacitance is a function of the voltage across the T/R switch. The $C_{SW(OFF)}$ is about 12 to 19 pF for 10V to 130V of the transmit voltage.

T_{ON} and T_{OFF} Time

The T_{ON} and T_{OFF} of the MD0105 are less than 20ns, which provide a fast switch between the transmit mode and the receive mode. The T_{ON} and T_{OFF} are input rise/fall time dependent. The T/R switch turns ON and OFF faster when the rise and fall times of the transmit pulse are faster. On the other hand, the switch turns ON and OFF slower if the rise and fall times of the transmit pulse are slower.

Pin Description

Pad	Name	Description
1	NC	No internal connection
2	A1	Switch terminal A1
3	NC	No internal connection
4	A2	Switch terminal A2
5	NC	No internal connection
6	A3	Switch terminal A3
7	NC	No internal connection
8	A4	Switch terminal A4
9	NC	No internal connection

Pad	Name	Description
10	NC	No internal connection
11	B4	Switch terminal B4
12	NC	No internal connection
13	B3	Switch terminal B3
14	NC	No internal connection
15	B2	Switch terminal B2
16	NC	No internal connection
17	B1	Switch terminal B1
18	NC	No internal connection
Center Tab	---	Connect to ground

18-Lead DFN Package Outline (K6)

5.00x5.00mm body, 1.00mm height (max), 0.50mm pitch

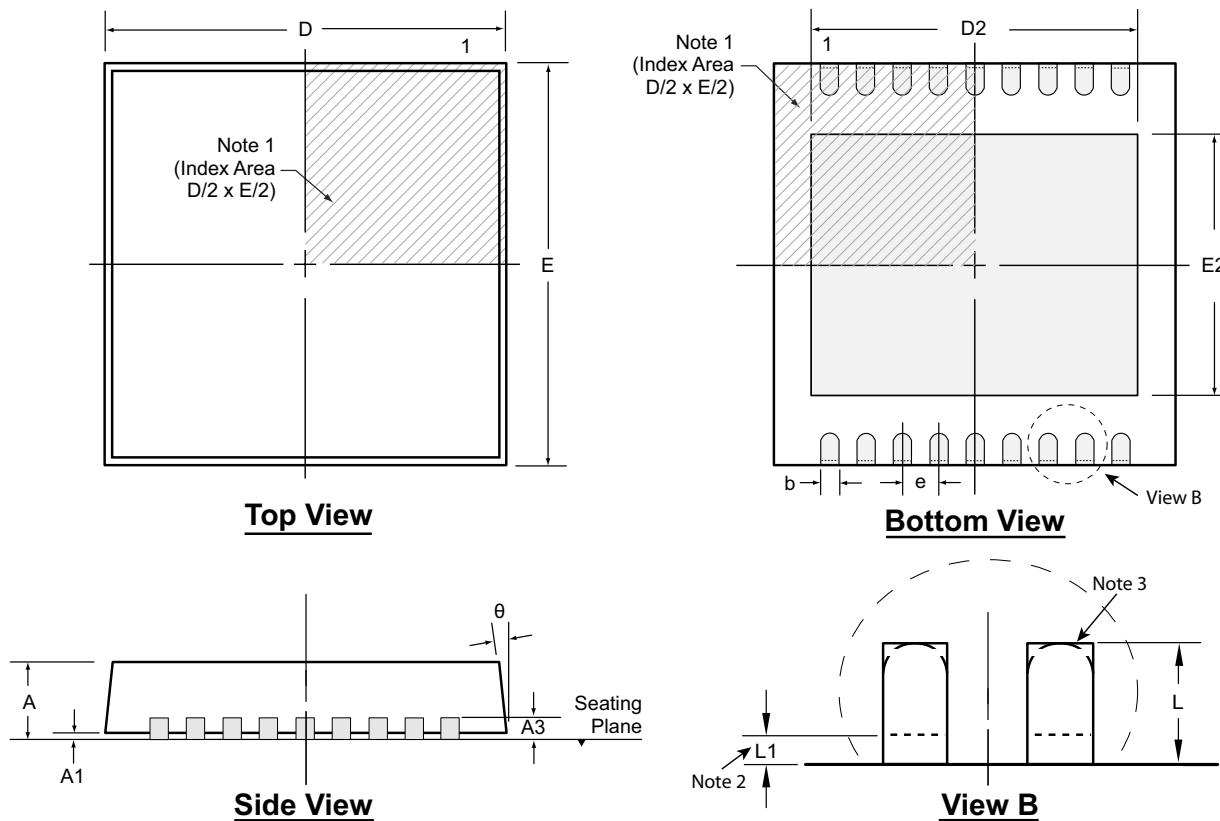

Notes:

1. A Pin 1 identifier must be located in the index area indicated. The Pin 1 identifier can be: a molded mark/identifier; an embedded metal marker; or a printed indicator.
2. Depending on the method of manufacturing, a maximum of 0.15mm pullback (L1) may be present.
3. The inner tip of the lead may be either rounded or square.

Symbol		A	A1	A3	b	D	D2	E	E2	e	L	L1	θ
Dimension (mm)	MIN	0.80	0.00	0.20 REF	0.18	4.85*	4.20†	4.85*	3.50†	0.50 BSC	0.30†	0.00*	0°
	NOM	0.90	0.02		0.25	5.00	4.35†	5.00	3.65†		0.40†	-	-
	MAX	1.00	0.05		0.30	5.15*	4.45†	5.15*	3.75†		0.50†	0.15	14°

JEDEC Registration MO-229, Variation VJJD-2, Issue C, Aug. 2003.

* This dimension is not specified in the JEDEC drawing.

† This dimension differs from the JEDEC drawing.

Drawings not to scale.

Supertex Doc. #: DSPD-18DFNK65X5P050, Version A013111.

(The package drawing(s) in this data sheet may not reflect the most current specifications. For the latest package outline information go to <http://www.supertex.com/packaging.html>.)

Supertex inc. does not recommend the use of its products in life support applications, and will not knowingly sell them for use in such applications unless it receives an adequate "product liability indemnification insurance agreement." Supertex inc. does not assume responsibility for use of devices described, and limits its liability to the replacement of the devices determined defective due to workmanship. No responsibility is assumed for possible omissions and inaccuracies. Circuitry and specifications are subject to change without notice. For the latest product specifications refer to the Supertex inc. (website: <http://www.supertex.com>)