

LINEAR IC**8-Bit D/A Converter
with Operational Amplifier Output Buffers****MB88344/88344B****■ DESCRIPTION**

MB88344/MB88344B are 8-bit 36 channels D/A converters which have two reference voltages to use 36 channels as 12 channels and 24 channels independently.

Each output channels has an operational amplifier output buffer and so large current drive is possible.

In the MB88344B, 6 Channels of DAC output (AO_{31} - AO_{36}) have four data registers each and so, the analog output can be changed by the address input from A0 and A1 pins.

Digital data are input to the devices in serial and it is controlled by CLK and LD pins. This configuration makes a cascade connections between devices.

The MB88344/MB88344B are suitable for electronic volumes and replacement for potentiometers for adjustment, in addition to normal D/A converter applications.

■ FEATURES

- Ultra low power consumption : Type. 1.1mW/channel
- Ultra small package
- Conversion method : R-2R resistor ladder
- On-chip operational amplifier output buffers : Max. +1.0/-1.0mA analog output sink/source current capability
- Analog data output range : 0 to V_{CC} [V]
- Two analog output reference voltage : Analog data can be output in different reference voltages.

*(Continued)***■ PACKAGES**

48 pin, Plastic SH-DIP

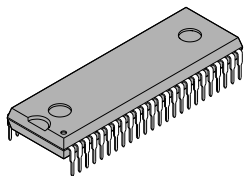

(DIP-48P-M01)

48 pin, Plastic QFP

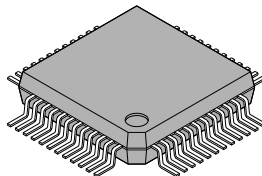

(FPT-48P-M16)

48 pin, Plastic LQFP

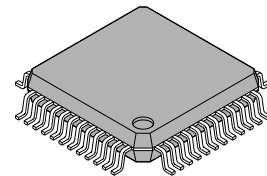

(FPT-48P-M05)

This device contains circuitry to protect the inputs against damage due to high static voltages or electric fields. However, it is advised that normal precautions be taken to avoid application of any voltage higher than maximum rated voltages to this high impedance circuit.

MB88344/MB88344B

(Continued)

- For data registers for AO₃₁-AO₃₆ channels (MB88344B only) : Analog output can be changed by the A0 and A1 analog block.
- Separate supply voltage for digital block and analog block.
- Direct control can be done from 3 V-system MCU:
 - MB88344 : Input "H" Voltage = 0.5 V_{CC}, Input "L" Voltage = 0.2 V_{CC}
 - MB88344B : Input "H" Voltage = 2.1 V, Input "L" Voltage = 0.6 V
- Max. 2.5 MHz serial data input
- Silicon-gate CMOS process
- Package options:
 - MB88344: 48-pin plastic SH-DIP/QFP/LQFP
 - MB88344B: 48-pin plastic SH-DIP/LQFP

MB88344/MB88344B

	MB88344	MB88344B
Number of digital for AO ₃₁ to AO ₃₆	1	4
Shift register	14-bit	16-bit
Shift register format	MSB first	LSB first
Package	SH-DIP-48P/QFP-48P/LQFP-48P	SH-DIP-48P/LQFP-48P

■ PIN ASSIGNMENTS

MB88344

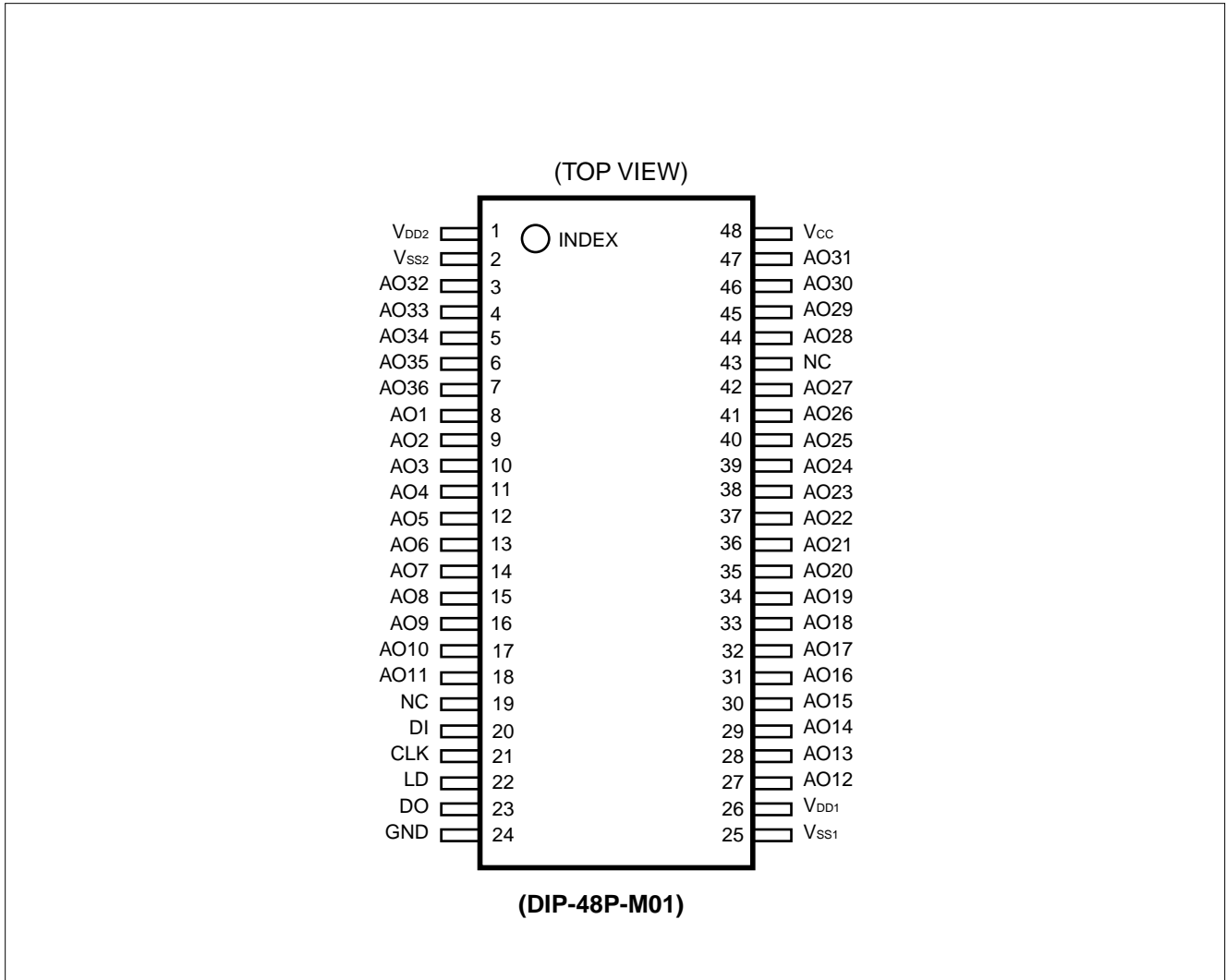

(Continued)

MB88344/MB88344B

(Continued)

(TOP VIEW)

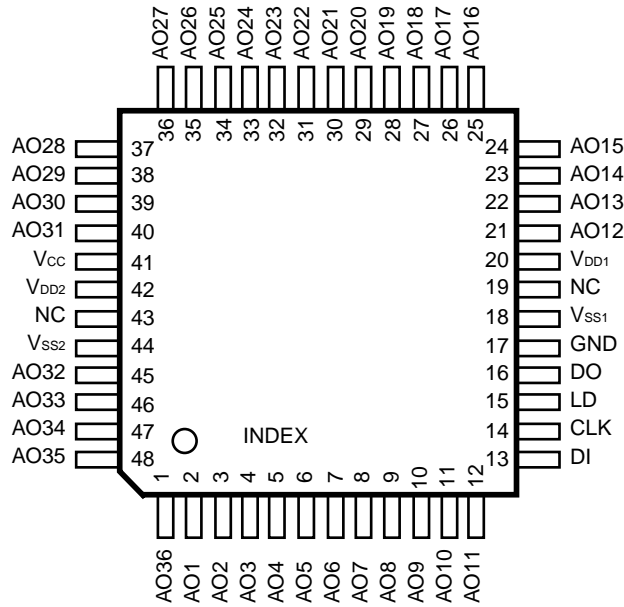

(FPT-48P-M16)

(TOP VIEW)

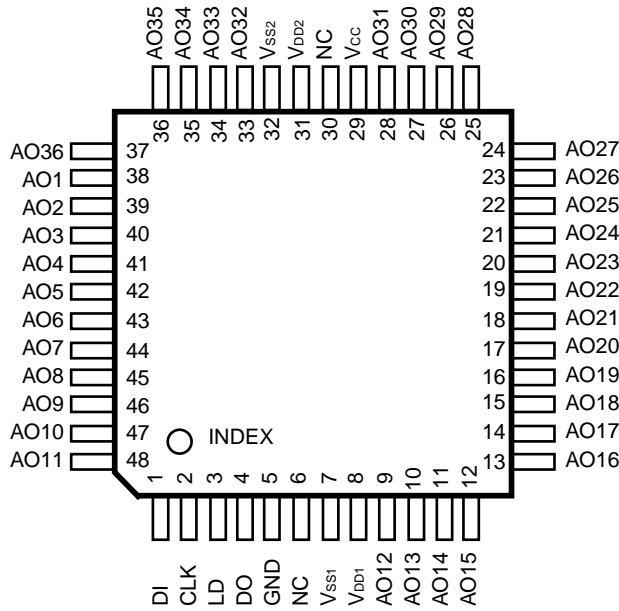

(FPT-48P-M05)

MB88344B

(TOP VIEW)

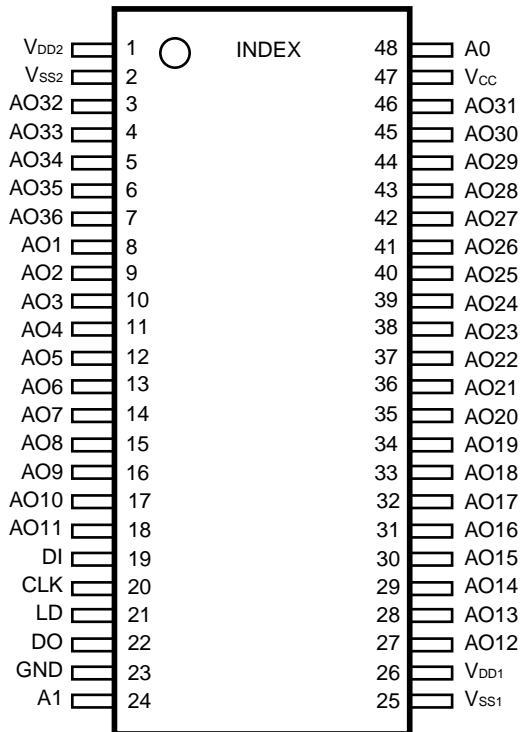

(DIP-48P-M01)

(TOP VIEW)

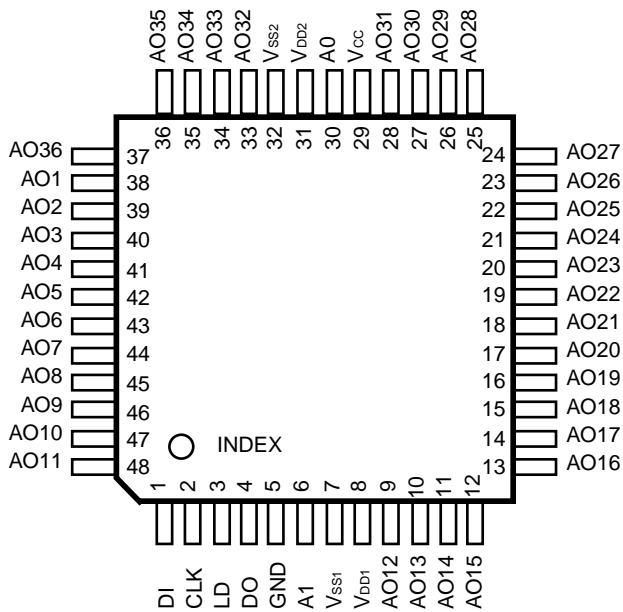

(FPT-48P-M05)

MB88344/MB88344B

■ PIN DESCRIPTION

Table 1 Pin Description

Pin name	Pin No.					I/O	Description
	MB88344			MB88344B			
	SH-DIP	QFP	LQFP	SH-DIP	LQFP		
DI*	20	13	1	19	1	I	Serial data input pin.
CLK*	21	14	2	20	2	I	Shift clock input pin. Serial data input from DI pin are input to the internal shift register by a rising edge of the CLK signal.
LD*	22	15	3	21	3	I	Load strobe input pin. A "high" level on this pin loads the shift register values into the decoder and 8-bit register.
DO	23	16	4	22	4	O	Serial data output pin. Serial data in the shift register are output from this pin. This pin allows a cascade connection of device.
AO ₁ to AO ₁₁	8 to 18	2 to 12	38 to 48	8 to 18	38 to 48	O	D/A converter outputs #1. The analog supply voltage is referred with V _{DD1} –V _{SS1} . Analog output has an operational amplifier output buffer.
AO ₁₂ to AO ₂₄	27 to 39	21 to 33	9 to 21	27 to 39	9 to 21		
AO ₂₅ to AO ₂₇	40 to 42	34 to 36	22 to 24	40 to 42	22 to 24	O	D/A converter outputs #2. The analog supply voltage is referred with V _{DD2} –V _{SS2} . Analog output has an operational amplifier output buffer.
AO ₂₈ to AO ₃₁	44 to 47	37 to 40	25 to 28	43 to 46	25 to 28		
AO ₃₂ to AO ₃₆	3 to 7	45 to 1	33 to 37	3 to 7	33 to 37		
A0	–	–	–	48	30	I	Address input pins to select the DAC output register for the AO ₃₁ –AO ₃₆ pins. (Those address inputs are not applied to other analog output pins.)
A1	–	–	–	24	6		
V _{CC}	48	41	29	47	29	–	Supply voltage pin for digital block and operational amplifier output buffers.
GND	24	17	5	23	5	–	Ground pin for digital block and op-amp. output buffers.
V _{DD1}	26	20	8	26	8	–	Supply voltage pin for D/A converter (for AO ₁ –AO ₂₄ outputs).
V _{SS1}	25	18	7	25	7	–	Ground pin for D/A converter (for AO ₁ –AO ₂₄ outputs).
V _{DD2}	1	42	31	1	31	–	Supply voltage pin for D/A converter (for AO ₂₅ –AO ₃₆ outputs).
V _{SS2}	2	44	32	2	32	–	Ground pin for D/A converter (for AO ₂₅ –AO ₃₆ outputs).
NC	19	19	6	–	–	–	No connection. Those are open pins and do not connect to those pins.
	43	43	30	–	–		

* : DI, CLK, and LD pins should be fixed with "Low" level while no data are transferred.

■ BLOCK DIAGRAM

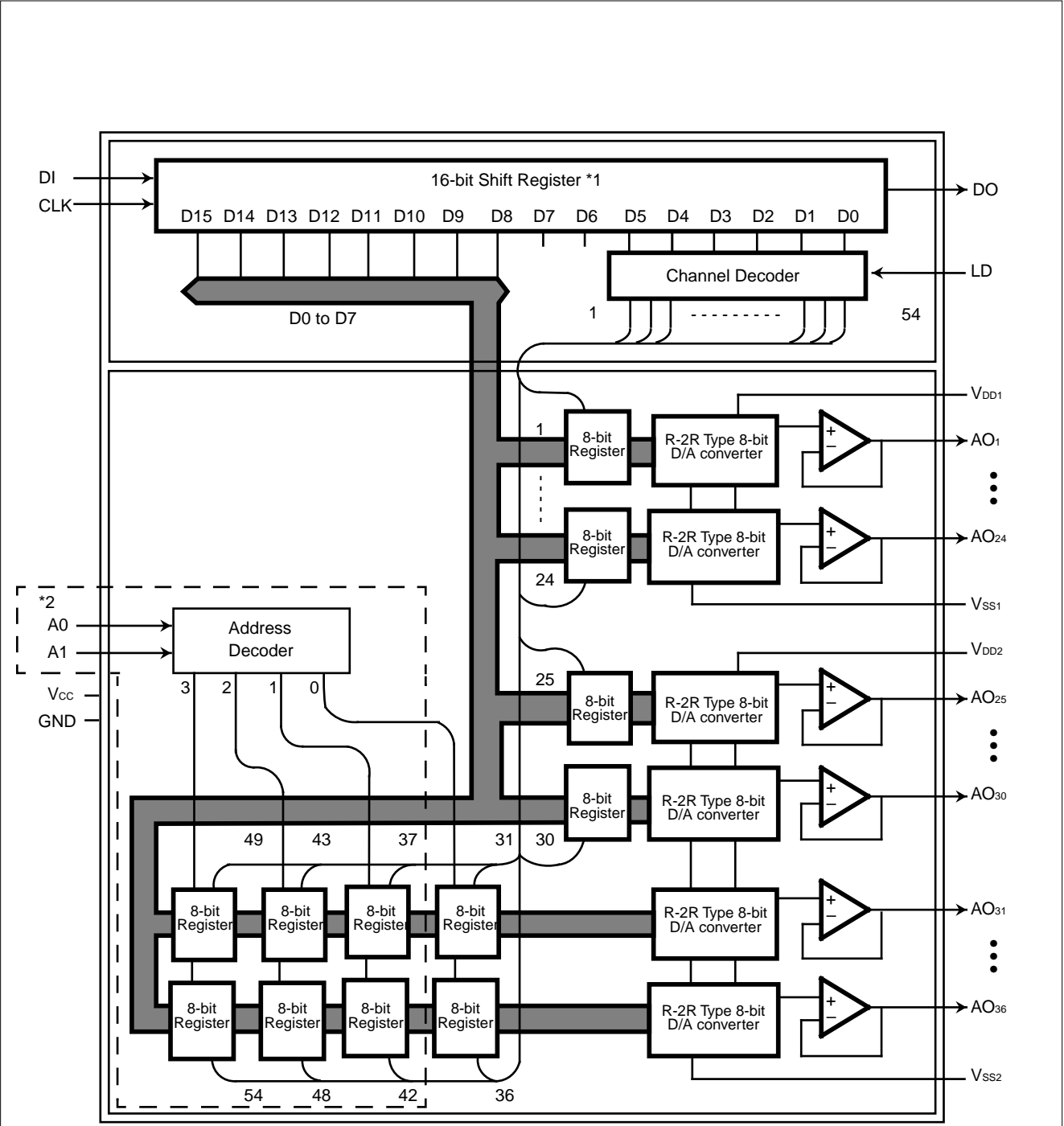

*1 : In MB88344, the Shift register is a 14-bit and the format is MSB-first.
 *2 : MB88344 does not have A0, A1 pins and register addresses #37 to #54.

MB88344/MB88344B

■ DEVICE CONTROL

The MB88344 has a 14-bit shift register, and MB88344B has a 16-bit shift register to store the digital data and channel selection.

1. 14-bit Shift Register (MB88344)

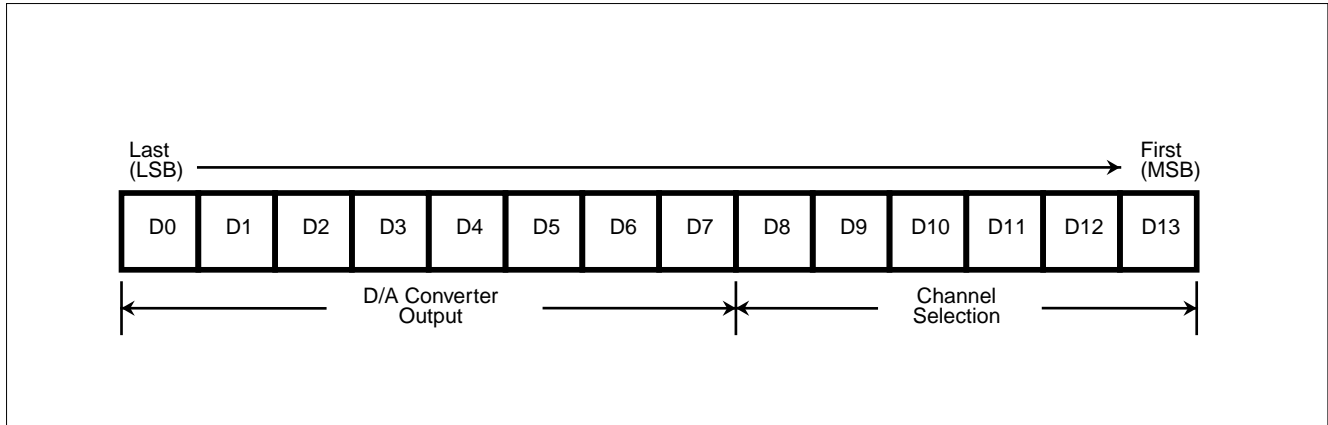

D/A Converter Output

Input data								DAC output
D0	D1	D2	D3	D4	D5	D6	D7	
0	0	0	0	0	0	0	0	$\cong V_{SS}$
1	0	0	0	0	0	0	0	$\cong V_{REF}/256 \times 1 + V_{SS}$
⋮	⋮	⋮	⋮	⋮	⋮	⋮	⋮	⋮
0	1	1	1	1	1	1	1	$\cong V_{REF}/256 \times 254 + V_{SS}$
1	1	1	1	1	1	1	1	$\cong V_{REF}/256 \times 255 + V_{SS}$

$$V_{REF} = V_{DD} - V_{SS}$$

Channel Selection

Input data						Selected channel
D8	D9	D10	D11	D12	D13	
0	0	0	0	0	0	Deselected
0	0	0	0	0	1	AO ₁ to AO ₃₀ selected
0	1	1	1	1	0	
0	1	1	1	1	1	AO ₃₁ to AO ₃₆ selected (address 0)
1	0	0	1	0	0	
1	0	0	1	0	1	Deselected
1	1	1	1	1	1	

MB88344/MB88344B

2. 016-bit Shift Register (MB88344B)

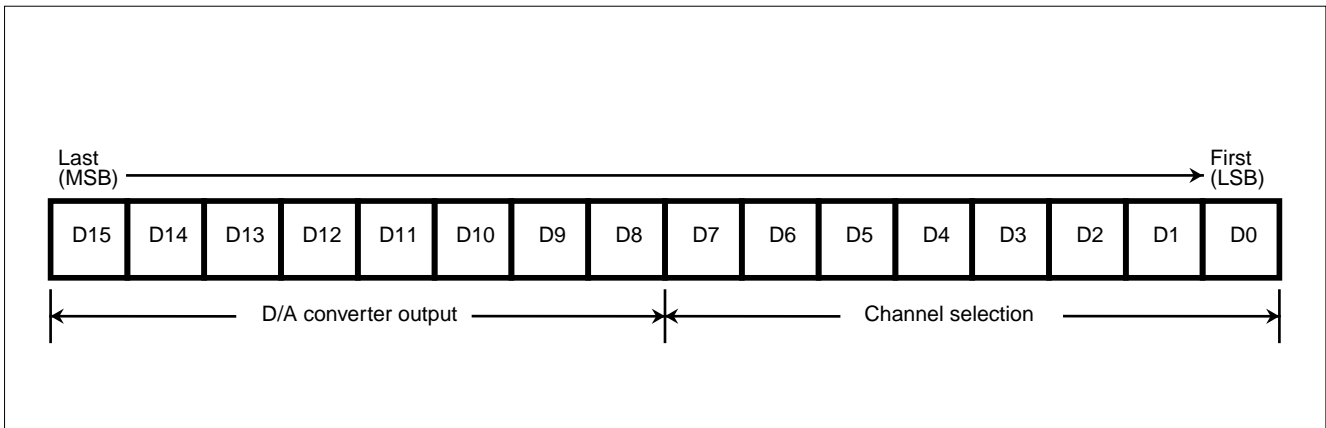

D/A Converter Output

Input data								DAC output
D15	D14	D13	D12	D11	D10	D9	D8	
0	0	0	0	0	0	0	0	$\equiv V_{SS}$
0	0	0	0	0	0	0	1	$\equiv V_{REF}/256 \times 1 + V_{SS}$
⋮	⋮	⋮	⋮	⋮	⋮	⋮	⋮	⋮
1	1	1	1	1	1	1	0	$\equiv V_{REF}/256 \times 254 + V_{SS}$
1	1	1	1	1	1	1	1	$\equiv V_{REF}/256 \times 255 + V_{SS}$

$$V_{REF} = V_{DD} - V_{SS}$$

Channel Selection

Input data								Selected channel
D7	D6	D5	D4	D3	D2	D1	D0	
×	×	0	0	0	0	0	0	Deselected
×	×	0	0	0	0	0	1	AO ₁ to AO ₃₀ selected
×	×	0	1	1	1	1	0	
×	×	0	1	1	1	1	1	AO ₃₁ to AO ₃₆ selected (address 0)
×	×	1	0	0	1	0	0	
×	×	1	0	0	1	0	1	AO ₃₁ to AO ₃₆ selected (address 1)
×	×	1	0	1	0	1	0	
×	×	1	0	1	0	1	1	AO ₃₁ to AO ₃₆ selected (address 2)
×	×	1	1	0	0	0	0	
×	×	1	1	0	0	0	1	AO ₃₁ to AO ₃₆ selected (address 3)
×	×	1	1	0	1	1	0	
×	×	1	1	0	1	1	1	Deselected
×	×	1	1	1	1	1	1	

×: Don't Care

Output Register Selection

A1	A0	Output register selected
0	0	address 0
0	1	address 1
1	0	address 2
1	1	address 3

MB88344/MB88344B

■ TIMING CHART

MB88344

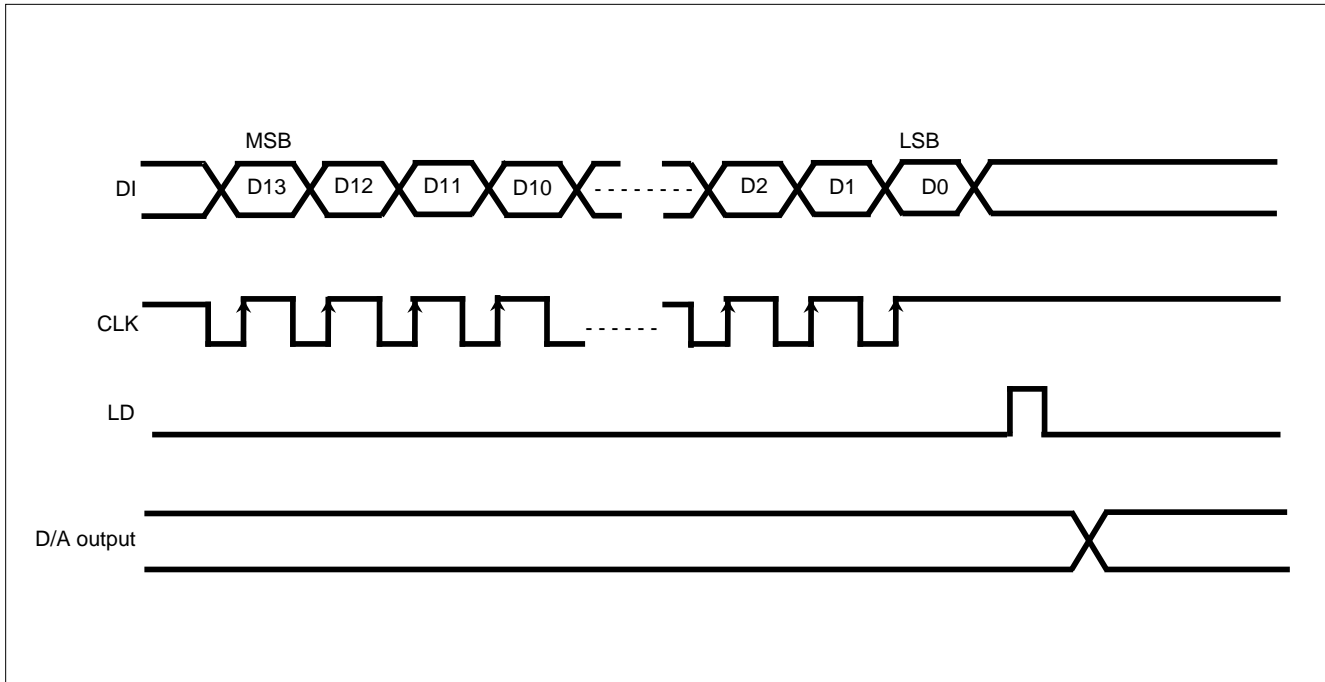

MB88344B

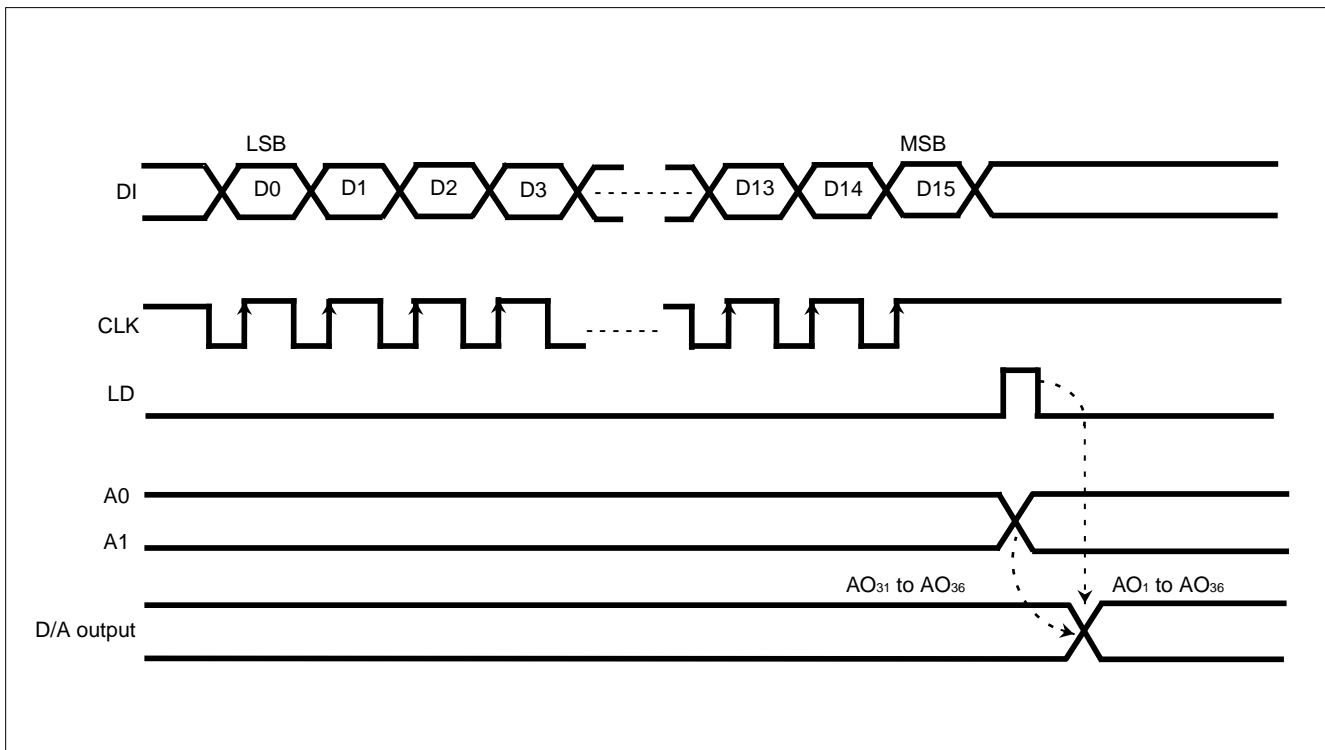

■ ANALOG OUTPUT VOLTAGE RANGE

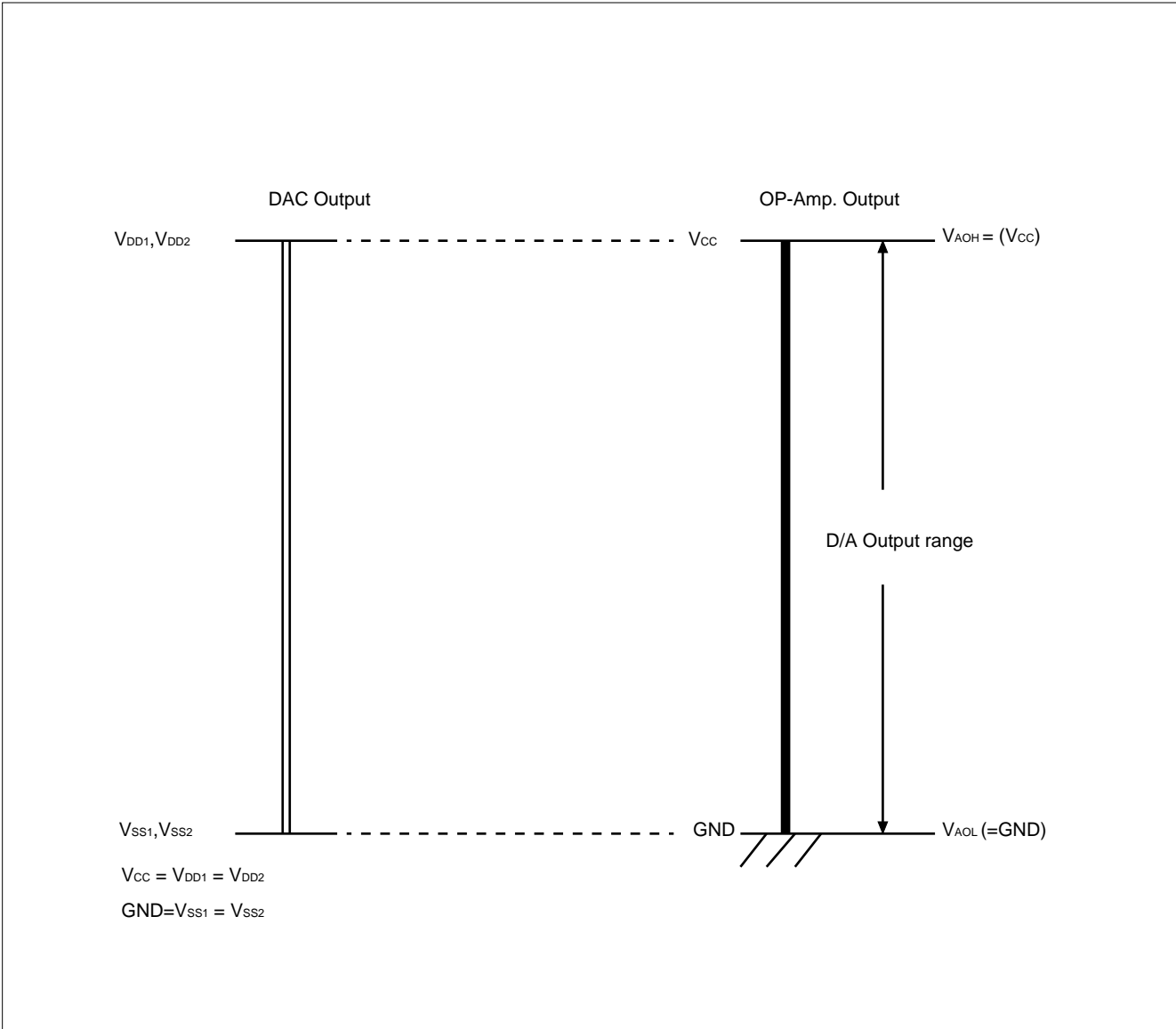

MB88344/MB88344B

■ ABSOLUTE MAXIMUM RATINGS (See WARNING)

Parameter	Symbol	Condition	Rating			Unit
			Min.	Typ.	Max.	
Power supply voltage	V_{CC}	$T_a = +25^\circ\text{C}$ $\text{GND} = 0\text{ V}, V_{DD1} \leq V_{CC},$ $V_{DD2} \leq V_{CC}$	-0.3	—	7.0	V
	V_{DD1}, V_{DD2}		-0.3	—	7.0	V
Input voltage	V_{IN}	$T_a = +25^\circ\text{C}$ $\text{GND} = 0\text{ V}$ Should not exceed $V_{CC} + 0.3\text{ V}$	-0.3	—	$V_{CC} + 0.3$	V
Output voltage	V_{OUT}		-0.3	—	$V_{CC} + 0.3$	V
Power dissipation	P_D	—	—	—	250	mW
Operating ambient temperature	T_a	—	-20	—	+85	$^\circ\text{C}$
Storage temperature	T_{STG}	—	-55	—	+150	$^\circ\text{C}$

WARNING: Semiconductor devices can be permanently damaged by application of stress (voltage, current, temperature, etc.) in excess of absolute maximum ratings. Do not exceed these ratings.

■ RECOMMENDED OPERATING CONDITIONS

Parameter	Symbol	Condition	Value			Unit
			Min	Typ.	Max.	
Power supply voltage (for MCU interface/ OP.-amp. block)	V_{CC}	$V_{CC} \geq V_{DD}$	4.5	5.0	5.5	V
	GND		—	0	—	V
Power supply voltage (for analog block*)	V_{DD1}, V_{DD2}	$V_{DD1} - V_{SS1} \geq 2.0\text{ V},$ $V_{DD2} - V_{SS2} \geq 2.0\text{ V}$	2.0	—	V_{CC}	V
	V_{SS1}, V_{SS2}		GND	—	$V_{CC} - 2.0$	V
Analog output source current	$ I_{AL} $	—	—	—	-1.0	mA
Analog output sink current	$ I_{AH} $	—	—	—	+1.0	mA
Analog output load capacitance for oscillation limit	C_{AL}	—	—	—	1.0	μF
Operating ambient temperature	T_a	—	-20	—	+85	$^\circ\text{C}$

* : Except operational amplifier output buffer block. Also, V_{DD1} (V_{SS1}) and V_{DD2} (V_{SS2}) can be set independently.

■ ELECTRICAL CHARACTERISTICS

1. DC Characteristics

(Recommended operating conditions unless otherwise noted.)

Digital Block (MCU Interface)

Parameter	Pin	Symbol	Condition	Value			Unit
				Min.	Typ.	Max.	
Active supply current (V _{CC})*	V _{CC}	I _{CC}	CLK = 1MHz, unloaded	—	3.5	8.0	mA
Input leakage current (CLK, DI, and LD)	CLK DI LD	I _{ILK}	V _{IN} = 0 to V _{CC}	-10	—	+10	μA
Input low voltage (CLK, DI, and LD)		V _{IL}	For MB88344	—	—	0.2•V _{CC}	V
			For MB88344B	—	—	0.6	V
Input high voltage (CLK, DI, and LD)		V _{IH}	For MB88344	0.5•V _{CC}	—	—	V
	For MB88344B		2.1	—	—	V	
Output low voltage (DO)	DO	V _{OL}	I _{OL} = 2.5 mA	—	—	0.4	V
Output high voltage (DO)		V _{OH}	I _{OH} = -400 μA	V _{CC} - 0.4	—	—	V

* : Including the supply current to the operational amplifier block

MB88344/MB88344B

Analog Block (D/A Converters with Operational Amplifier Output Buffers)

Parameter	Symbol	Pin	Condition	Value			Unit
				Min.	Typ.	Max.	
Supply current (V _{DD})**	I _{DD}	V _{DD1} V _{DD2}	Unloaded, I _{DD} is a total current value for DAC outputs #1 and #2.	—	4.5	6.5	mA
Min. analog output voltage 1 (AO _x)	V _{AO1}	AO ₁ to AO ₃₆	V _{DD1,2} = V _{CC} V _{SS1,2} = GND = 0.0 V I _{AL} = 0 μA Digital data = #00	V _{SS1,2}	—	V _{SS1,2} + 0.1	V
Min. analog output voltage 2 (AO _x)	V _{AO2}		V _{DD1,2} = V _{CC} = 5.0 V V _{SS1,2} = GND = 0.0 V I _{AL} = 500 μA Digital data = #00	V _{SS1,2} - 0.2	V _{SS1,2}	V _{SS1,2} + 0.2	V
Min. analog output voltage 3 (AO _x)	V _{AO3}		V _{DD1,2} = V _{CC} = 5.0 V V _{SS1,2} = GND = 0.0 V I _{AH} = 500 μA Digital data = #00	V _{SS1,2}	—	V _{SS1,2} + 0.2	V
Min. analog output voltage 4 (AO _x)	V _{AO4}		V _{DD1,2} = V _{CC} = 5.0 V V _{SS1,2} = GND = 0.0 V I _{AL} = 1.0 mA Digital data = #00	V _{SS1,2} - 0.3	V _{SS1,2}	V _{SS1,2} + 0.3	V
Min. analog output voltage 5 (AO _x)	V _{AO5}		V _{DD1,2} = V _{CC} = 5.0 V V _{SS1,2} = GND = 0.0 V I _{AH} = 1.0 mA Digital data = #00	V _{SS1,2}	—	V _{SS1,2} + 0.3	V
Max. analog output voltage 1 (AO _x)	V _{AOH1}		V _{DD1,2} = V _{CC} V _{SS1,2} = GND = 0.0 V I _{AL} = 0 μA Digital data = #FF	V _{DD1,2} - 0.1	—	V _{DD1,2}	V
Max. analog output voltage 2 (AO _x)	V _{AOH2}		V _{DD1,2} = V _{CC} = 5.0 V V _{SS1,2} = GND = 0.0 V I _{AL} = 500 μA Digital data = #FF	V _{DD1,2} - 0.2	—	V _{DD1,2}	V
Max. analog output voltage 3 (AO _x)	V _{AOH3}		V _{DD1,2} = V _{CC} = 5.0 V V _{SS1,2} = GND = 0.0 V I _{AH} = 500 μA Digital data = #FF	V _{DD1,2} - 0.2	V _{DD1,2}	V _{DD1,2} + 0.2	V
Max. analog output voltage 4 (AO _x)	V _{AOH4}		V _{DD1,2} = V _{CC} = 5.0 V V _{SS1,2} = GND = 0.0 V I _{AL} = 1.0 mA Digital data = #FF	V _{DD1,2} - 0.3	—	V _{DD1,2}	V
Max. analog output voltage 5 (AO _x)	V _{AOH5}		V _{DD1,2} = V _{CC} = 5.0 V V _{SS1,2} = GND = 0.0 V I _{AH} = 1.0 mA Digital data = #FF	V _{DD1,2} - 0.3	V _{DD1,2}	V _{SS1,2} + 0.3	V
Resolution (AO _x)	Res			—	8	—	bit
Linearity error (AO _x)	LE			Unloaded, V _{DD} ≤ V _{CC} -0.1 V, V _{SS} ≥ 0.1 V	-1.5	—	1.5
Differential linearity error (AO _x)	DLE		Unloaded	-1.0	—	1.0	LSB

** : Excluding the supply current to the operational amplifier block

2. AC Characteristics

(Recommended operating conditions unless otherwise noted.)

Parameter	Symbol	Condition	Value		Unit
			Min.	Max.	
Clock low time	t_{CKL}	—	200	—	ns
Clock high time	t_{CKH}	—	200	—	ns
Clock rise time	t_{Cr}	—	—	200	ns
Clock fall time	t_{Cf}	—	—	200	ns
Data setup time	t_{DCH}	—	30	—	ns
Data hold time	t_{CHD}	—	60	—	ns
Load strobe high time	t_{LDH}	—	100	—	ns
Load strobe setup time	t_{CHL}	—	200	—	ns
Load strobe hold time	t_{LDC}	—	100	—	ns
DAC output setting time	t_{LDD}	* $R_{AL} = 10\text{ k}\Omega$, $C_{AL} = 50\text{ pF}$	—	100	μs
Data output delay time	t_{DO}	** $C_L = 20\text{ pF (Min.)}$, 100 pF (Max.)	70	350	ns

■ DEFINITION OF NONLINEARITY ERROR

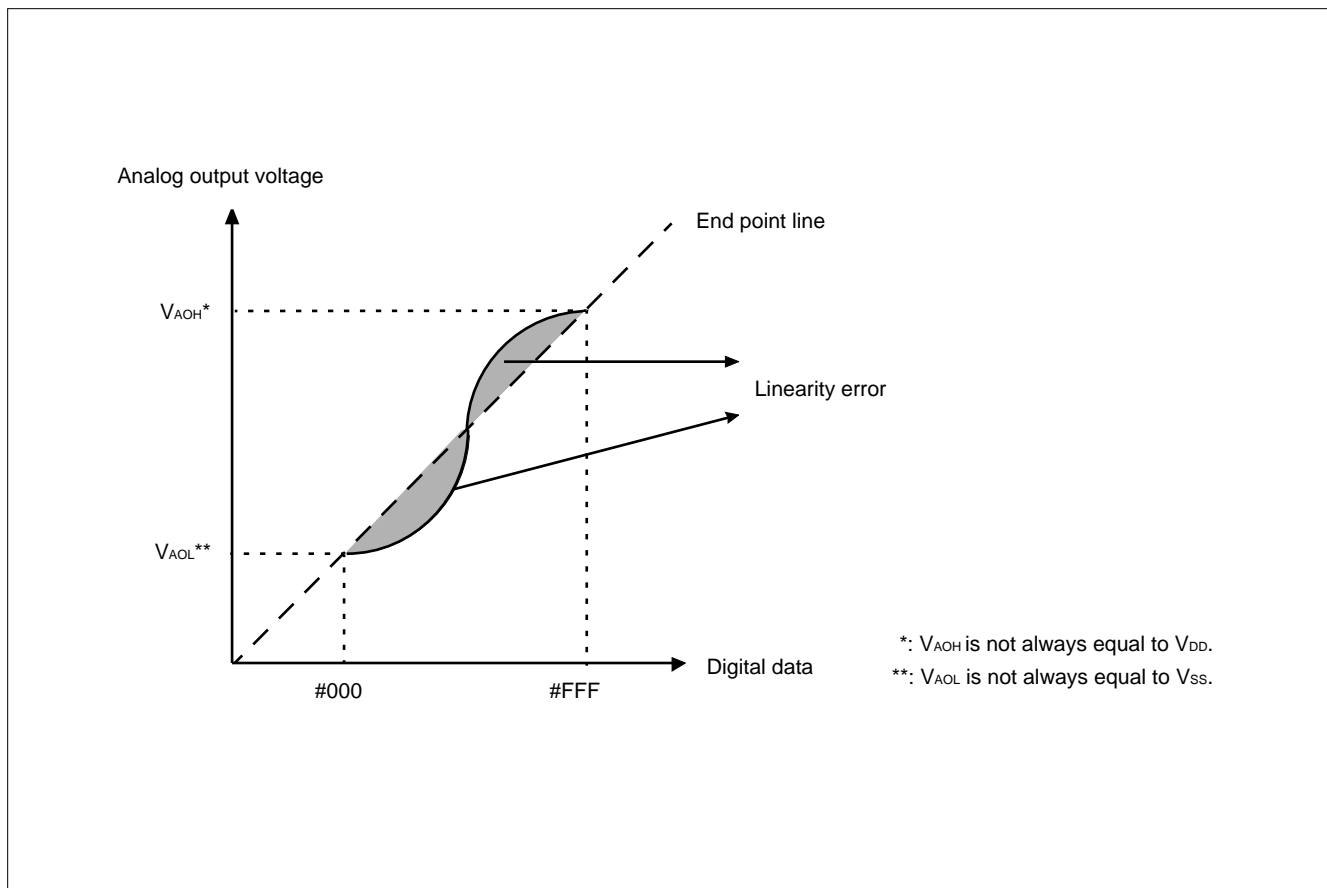

MB88344/MB88344B

AC TEST CONDITIONS

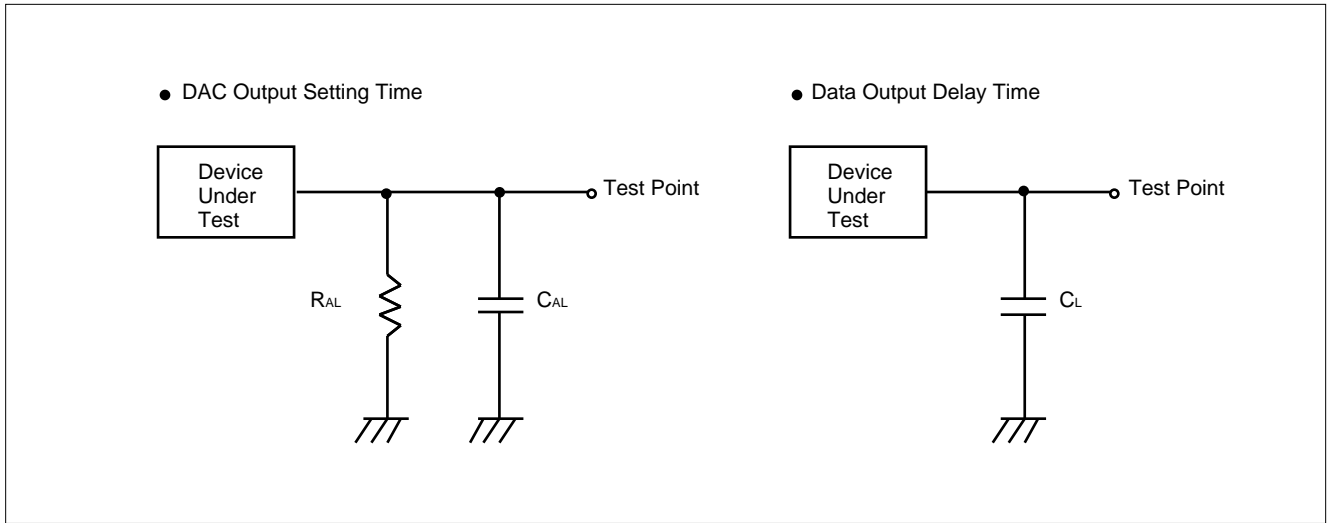

INPUT/OUTPUT TIMING

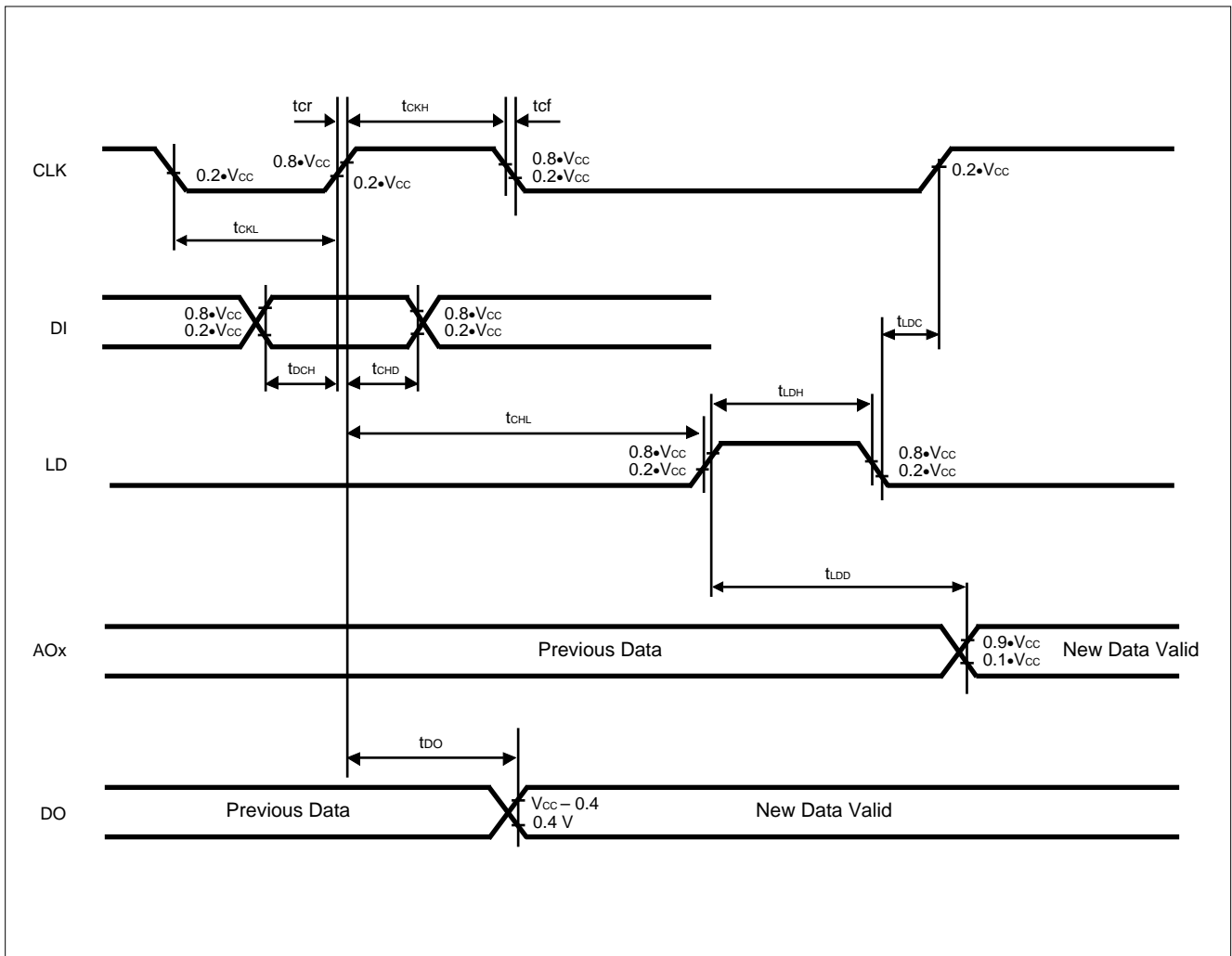

■ V_{AO} vs. I_{AO} CHARACTERISTIC CURVE (EXAMPLE)

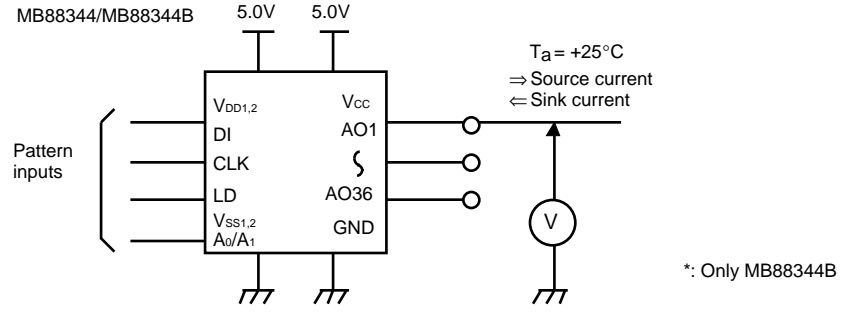
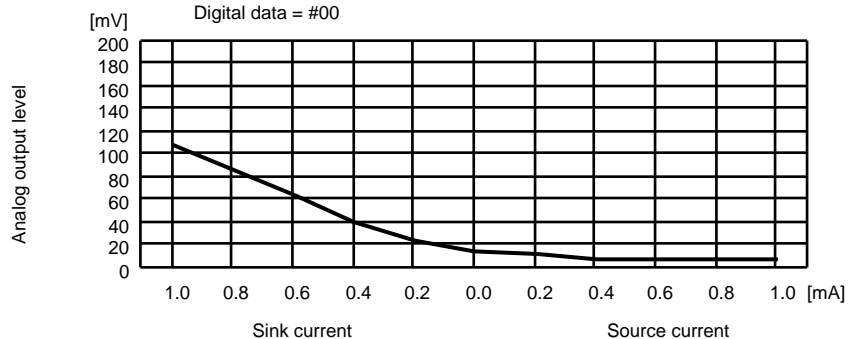
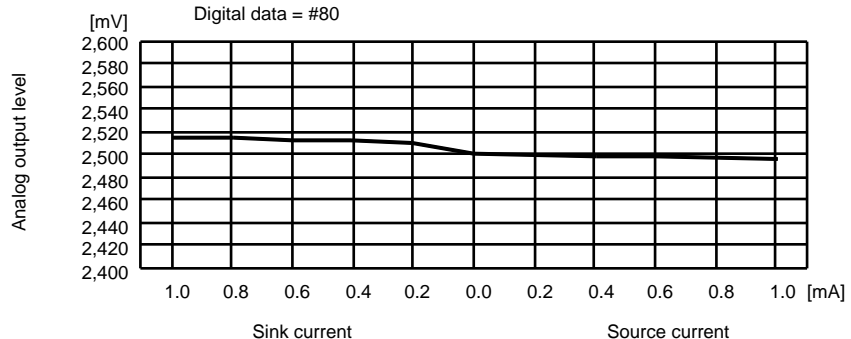
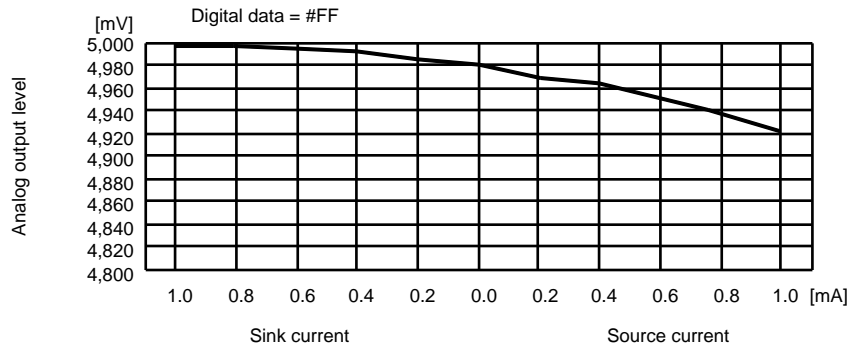

MB88344/MB88344B

■ PACKAGE DIMENSIONS

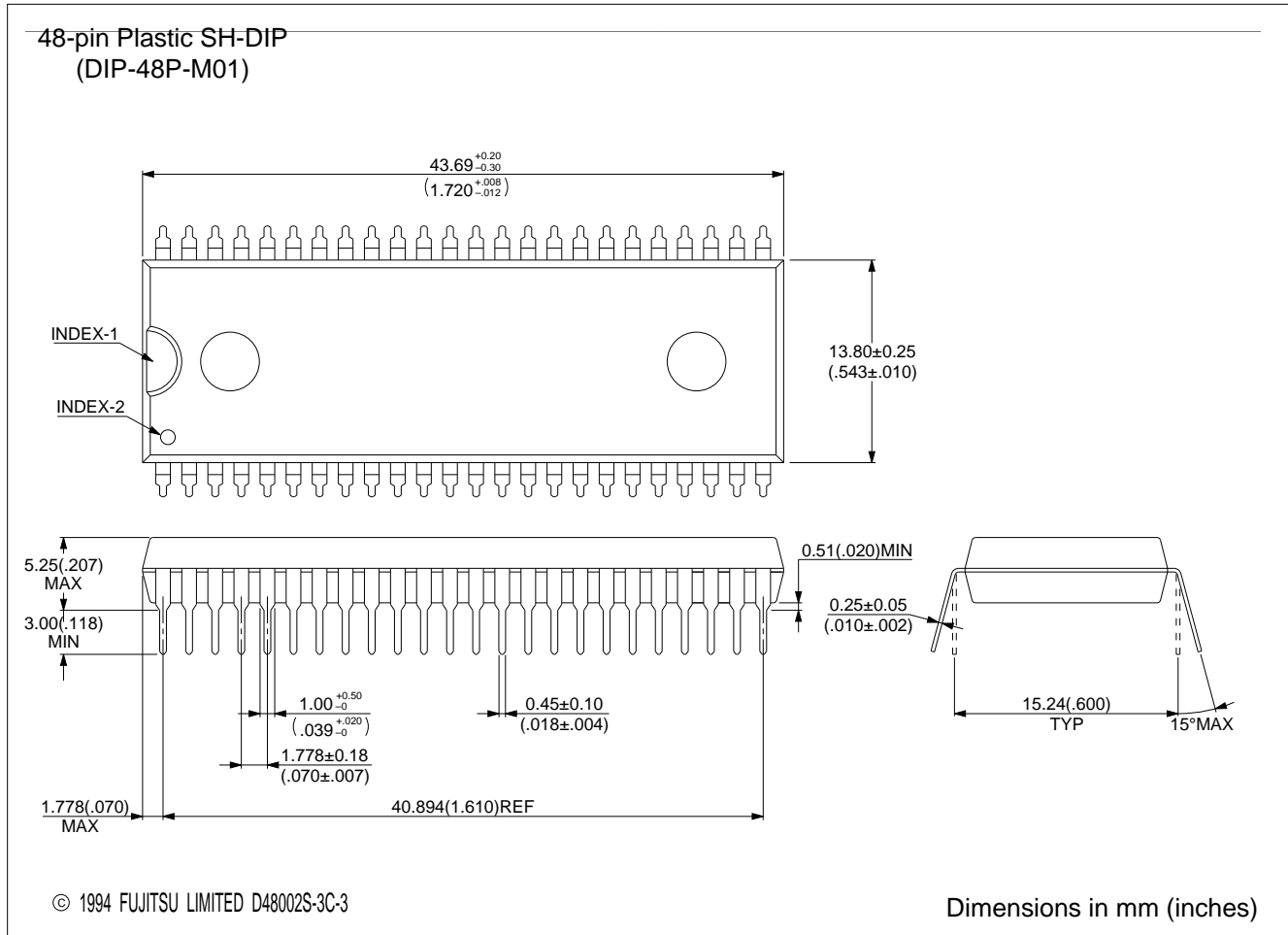

(Continued)

(Continued)

48-pin Plastic QFP
(FPT-48P-M16)

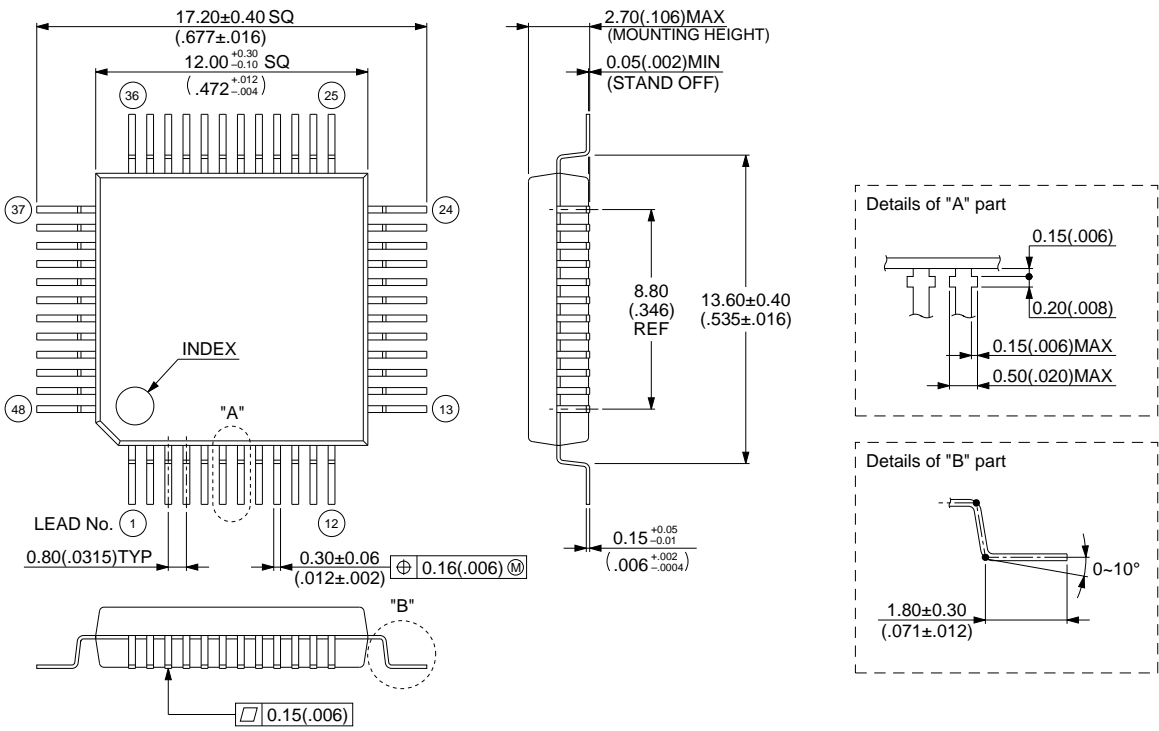

© 1994 FUJITSU LIMITED F48026S-1C-1

Dimensions in mm (inches)

(Continued)

MB88344/MB88344B

(Continued)

48-pin Plastic LQFP
(FPT-48P-M05)

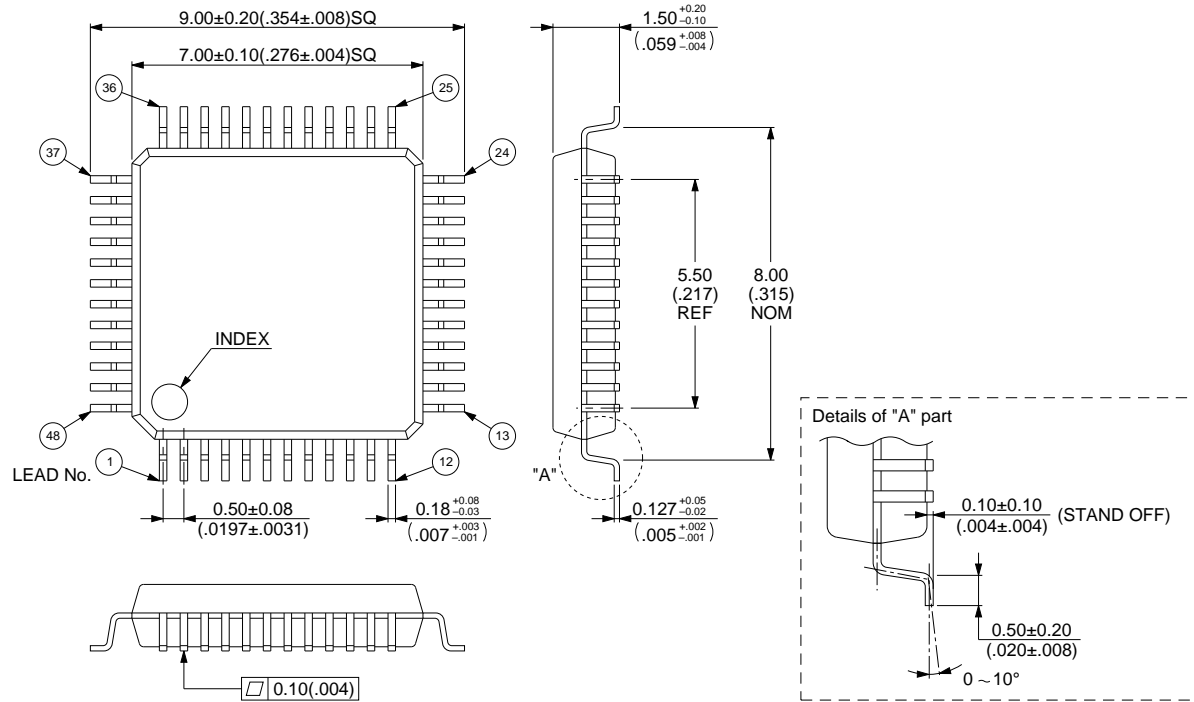

© 1994 FUJITSU LIMITED F48013S-2C-4

Dimensions in mm (inches)

FUJITSU LIMITED

For further information please contact:

Japan

FUJITSU LIMITED
Corporate Global Business Support Division
Electronic Devices
KAWASAKI PLANT, 4-1-1, Kamikodanaka
Nakahara-ku, Kawasaki-shi
Kanagawa 211-88, Japan
Tel: (044) 754-3763
Fax: (044) 754-3329

North and South America

FUJITSU MICROELECTRONICS, INC.
Semiconductor Division
3545 North First Street
San Jose, CA 95134-1804, U.S.A.
Tel: (408) 922-9000
Fax: (408) 432-9044/9045

Europe

FUJITSU MIKROELEKTRONIK GmbH
Am Siebenstein 6-10
63303 Dreieich-Buchsschlag
Germany
Tel: (06103) 690-0
Fax: (06103) 690-122

Asia Pacific

FUJITSU MICROELECTRONICS ASIA PTE. LIMITED
#05-08, 151 Lorong Chuan
New Tech Park
Singapore 556741
Tel: (65) 281-0770
Fax: (65) 281-0220

F9704

© FUJITSU LIMITED Printed in Japan

All Rights Reserved.

The contents of this document are subject to change without notice. Customers are advised to consult with FUJITSU sales representatives before ordering.

The information and circuit diagrams in this document presented as examples of semiconductor device applications, and are not intended to be incorporated in devices for actual use. Also, FUJITSU is unable to assume responsibility for infringement of any patent rights or other rights of third parties arising from the use of this information or circuit diagrams.

FUJITSU semiconductor devices are intended for use in standard applications (computers, office automation and other office equipment, industrial, communications, and measurement equipment, personal or household devices, etc.).

CAUTION:

Customers considering the use of our products in special applications where failure or abnormal operation may directly affect human lives or cause physical injury or property damage, or where extremely high levels of reliability are demanded (such as aerospace systems, atomic energy controls, sea floor repeaters, vehicle operating controls, medical devices for life support, etc.) are requested to consult with FUJITSU sales representatives before such use. The company will not be responsible for damages arising from such use without prior approval.

Any semiconductor devices have inherently a certain rate of failure. You must protect against injury, damage or loss from such failures by incorporating safety design measures into your facility and equipment such as redundancy, fire protection, and prevention of over-current levels and other abnormal operating conditions.

If any products described in this document represent goods or technologies subject to certain restrictions on export under the Foreign Exchange and Foreign Trade Control Law of Japan, the prior authorization by Japanese government should be required for export of those products from Japan.