

Fractional Load RS-485 and RS-422 Isolated Transceivers

Functional Diagrams

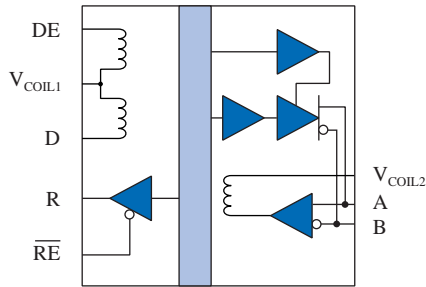

IL3285

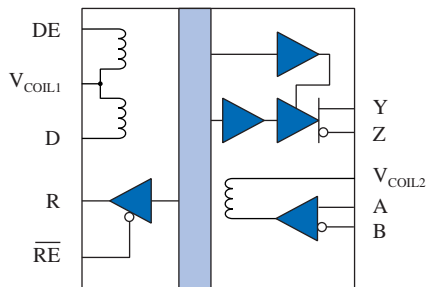

IL3222

IL3285 Truth Table

$V_{(A-B)}$	DE	D	R	RE	Mode
≥ 200 mV	H	H	H	L	Drive
≤ -200 mV	H	L	L	L	Drive
≥ 200 mV	L	X	H	L	Receive
≤ -200 mV	L	X	L	L	Receive
X	X	X	Z	H	X
Open	L	X	H	L	Receive

Z = High Impedance X = Irrelevant

IL 3222 Receiver

RE-bar	R	$V_{(A-B)}$
H	Z	X
L	H	≥ 200 mV
L	L	≤ -200 mV
L	H	Open

IL3222 Driver

DE	D	$V_{(Y-Z)}$
L	X	Z
H	H	≥ 200 mV
H	L	≤ -200 mV

Selection Table

Model	Full/Half Duplex	No. of Devices Allowed on Bus	Data Rate Mbps	Fail-Safe
IL3285	half	256	5	yes
IL3222	full	256	5	yes

IsoLoop® is a registered trademark of NVE Corporation.

*U.S. Patent number 5,831,426; 6,300,617 and others.

Features

- 3.3 V / 5 V Input Supply Compatible
- 5 Mbps Data Rate
- 1/8 Unit Load
- ± 15 kV ESD Protection
- 2500 V_{RMS} Isolation (1 minute)
- 20 kV/ μ s Typical Common Mode Rejection
- 15 kV bus ESD protection
- Low EMC Footprint
- -40°C to $+85^{\circ}\text{C}$ Temperature Range
- Thermal Shutdown Protection
- UL1577 and IEC 61010-2001 Approved
- 0.15" or 0.3" 16-pin SOIC Packages

Applications

- High Node-Count Networks
- Security Networks
- Building Environmental Controls
- Industrial Control Networks
- Gaming Systems

Description

The IL3285 and IL3222 are galvanically isolated, differential bus transceivers designed for bidirectional data communication over balanced transmission lines. The devices use NVE's patented* IsoLoop spintronic Giant Magnetoresistance (GMR) technology. The IL3285 delivers at least 1.5 V into a 54 Ω load, and the IL3222 at least 2 V into a 100 Ω load, allowing excellent data integrity over long cables. These devices are also compatible with 3.3 V input supplies, allowing interface to standard microcontrollers without additional level shifting.

Both the IL3285 and IL3222 have current limiting and thermal shutdown features to protect against output short circuits and bus contentions that may cause excessive power dissipation. The receivers also incorporate a "fail-safe if open" design, ensuring a logic high on R if the bus lines are disconnected or "floating."

Receiver input resistance of 96 k Ω is eight times the RS-485 "Unit Load" (UL) minimum of 12 k Ω . Thus these products are known as "one-eighth UL" transceivers. There can be up to 256 of these devices on a network while still complying with the RS-485 loading specification.

A capacitor (C_{Boost} ; see page 7) must be placed across the current limit resistor to ensure the full specified performance.

REV. K

Absolute Maximum Ratings

Operating at absolute maximum ratings will not damage the device. However, extended periods of operation at the absolute maximum ratings may affect performance and reliability.

Parameters	Symbol	Min.	Typ.	Max.	Units	Test Conditions
Storage Temperature	T_S	-65		150	°C	
Ambient Operating Temperature	T_A	-40		85	°C	
Voltage Range at A or B Bus Pins		-7		12	V	
Supply Voltage ⁽¹⁾	V_{DD1}, V_{DD2}	-0.5		7	V	
Digital Input Voltage		-0.5		$V_{DD}+0.5$	V	
Digital Output Voltage		-0.5		$V_{DD}+1$	V	
ESD Protection		±15			kV	
Input Current	I_{IN}	-25		+25	mA	
ESD (all bus nodes)		15			kV	HBM

Recommended Operating Conditions

Parameters	Symbol	Min.	Typ.	Max.	Units	Test Conditions
Supply Voltage	V_{DD1} V_{DD2}	3.0 4.5		5.5 5.5	V	
Ambient Operating Temperature	T_A	-40		85	°C	
Input Voltage at any Bus Terminal (separately or common mode)	V_I V_{IC}			12 -7	V	
Input Threshold for Output Logic High	I_{INH}		1.5	0.8	mA	
Input Threshold for Output Logic Low	I_{INL}	5	3.5		mA	
Differential Input Voltage ⁽²⁾	V_{ID}			+12/-7	V	
High-Level Output Current (Driver)	I_{OH}			-60	mA	
High-Level Digital Output Current (Receiver)	I_{OH}	-8		8	mA	
Low-Level Output Current (Driver)	I_{OL}	-60		60	mA	
Low-Level Digital Output Current (Receiver)	I_{OL}	-8		8	mA	
Ambient Operating Temperature	T_A	-40		85	°C	
Digital Input Signal Rise, Fall Times	t_{IR}, t_{IF}			1	µs	

Insulation Specifications

Parameters	Symbol	Min.	Typ.	Max.	Units	Test Conditions
Creepage Distance (external)		8.08			mm	
Barrier Impedance			$>10^{14} 7$		ΩpF	
Leakage Current			0.2		µA	240 V_{RMS} , 60 Hz

Safety Approvals

IEC61010-2001

TUV Certificate Numbers: N1502812, N1502812-101

Classification: Reinforced Insulation

Model	Package	Pollution Degree	Material Group	Max. Working Voltage
IL3222E, IL3285E, IL3222-3E, IL3285-3E	SOIC (0.15" and 0.3")	II	III	300 V_{RMS}

UL 1577

Rated 2500 V_{RMS} for 1 minute

Component Recognition Program File Number: E207481

Soldering Profile

Per JEDEC J-STD-020C, MSL=2

Electrostatic Discharge Sensitivity

This product has been tested for electrostatic sensitivity to the limits stated in the specifications. However, NVE recommends that all integrated circuits be handled with appropriate care to avoid damage. Damage caused by inappropriate handling or storage could range from performance degradation to complete failure.

IL3285-3 Pin Connections (0.15" SOIC Package)

1	V _{DD1}	Input power supply
2	GND ₁	Ground return for V _{DD1}
3	R	Output data from bus
4	$\overline{\text{RE}}$	Read enable (if RE is high, R is high impedance)
5	DE	Drive enable
6	V _{COIL1}	Coils for DE and D (connect to V _{DD1})
7	D	Data input to bus
8	NC	No internal connection
9	GND ₂	Ground return for V _{DD2}
10	NC	No internal connection
11	V _{DD2}	Output power supply
12	A	Non-inverting bus line
13	B	Inverting bus line
14	NC	No internal connection
15	GND ₂	Ground return for V _{DD2}
16	V _{COIL2}	Coil for R (connect to V _{DD2})

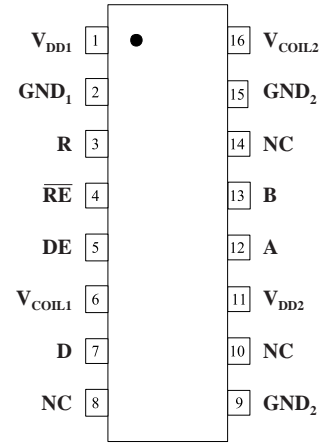

IL3285-3

IL3222-3 Pin Connections (0.15" SOIC Package)

1	V _{DD1}	Input power supply
2	GND ₁	Ground return for V _{DD1}
3	R	Output data from bus
4	$\overline{\text{RE}}$	Read enable (if RE is high, R is high impedance)
5	DE	Drive enable
6	V _{COIL1}	Coils for DE and D (connect to V _{DD1})
7	D	Data input to bus
8	NC	No internal connection
9	GND ₂	Ground return for V _{DD2}
10	Y	Non-inverting driver bus line
11	V _{DD2}	Output power supply
12	Z	Inverting driver bus line
13	B	Inverting receiver bus line
14	A	Non-inverting receiver bus line
15	GND ₂	Ground return for V _{DD2}
16	V _{COIL2}	Coil for R (connect to V _{DD2})

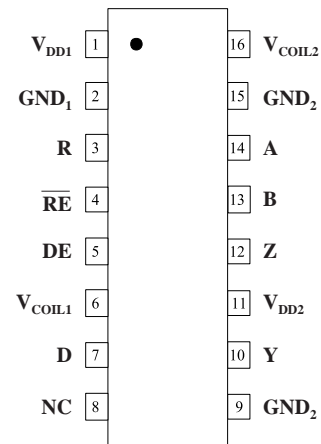

IL3222-3

IL3285 Pin Connections (0.3" SOIC Package)

1	V _{DD1}	Input power supply
2	GND ₁	Ground return for V _{DD1}
3	R	Output data from bus
4	$\overline{\text{RE}}$	Read enable (if RE is high, R is high impedance)
5	DE	Drive enable
6	V _{COIL1}	Coils for DE and D (connect to V _{DD1})
7	D	Data input to bus
8	GND ₁	V _{DD1} ground return for 0.3" package (no internal connection on 0.15" IL3285-3)
9	GND ₂	Ground return for V _{DD2}
10	NC	No internal connection
11	V _{DD2}	Output power supply
12	A	Non-inverting bus line
13	B	Inverting bus line
14	NC	No internal connection
15	GND ₂	Ground return for V _{DD2}
16	V _{COIL2}	Coil for R (connect to V _{DD2})

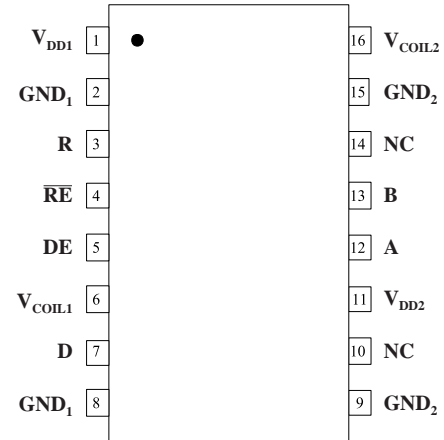

IL3285

IL3222 Pin Connections (0.3" SOIC Package)

1	V _{DD1}	Input power supply
2	GND ₁	Ground return for V _{DD1}
3	R	Output data from bus
4	$\overline{\text{RE}}$	Read enable (if RE is high, R is high impedance)
5	DE	Drive enable
6	V _{COIL1}	Coils for DE and D (connect to V _{DD1})
7	D	Data input to bus
8	GND ₁	V _{DD1} ground return for 0.3" package (no internal connection on 0.15" IL3222-3)
9	GND ₂	Ground return for V _{DD2}
10	Y	Non-inverting driver bus line
11	V _{DD2}	Output power supply
12	Z	Inverting driver bus line
13	B	Inverting receiver bus line
14	A	Non-inverting receiver bus line
15	GND ₂	Ground return for V _{DD2}
16	V _{COIL2}	Coil for R (connect to V _{DD2})

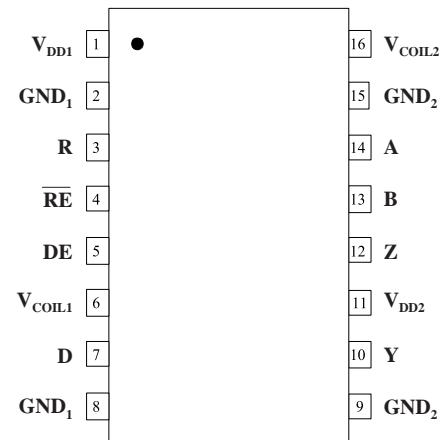

IL3222

Driver Section

Electrical specifications are T_{min} to T_{max} unless otherwise stated.

Parameters	Symbol	Min.	Typ.	Max.	Units	Test Conditions
Coil Input Impedance	Z_{COIL}		85 9		ΩnH	$T_{AMB} = 25^{\circ}C$ $V_{DD} = 3.0 V$ to $5.5 V$
Temperature Coefficient of Coil Resistance	TC R_{COIL}		0.2	0.25	$\Omega/^{\circ}C$	$V_{DD} = 3.0 V$ to $5.5 V$
Output voltage				V_{DD}	V	$I_O = 0$
Differential Output Voltage	$ V_{OD1} $			V_{DD}	V	$I_O = 0$
Differential Output Voltage	$ V_{OD2} $	2	3		V	$R_L = 100 \Omega$, $V_{DD} = 5 V$
Differential Output Voltage ⁽⁶⁾	V_{OD3}	1.5	2.3		V	$R_L = 54 \Omega$, $V_{DD} = 5 V$
Change in Magnitude ⁽⁷⁾ of Differential Output Voltage	$\Delta V_{OD} $			± 0.2	V	$R_L = 54 \Omega$ or 100Ω
Common Mode Output Voltage	V_{OC}			3	V	$R_L = 54 \Omega$ or 100Ω
Change in Magnitude ⁽⁷⁾ of Common Mode Output Voltage	$\Delta V_{OC} $			0.2	V	$R_L = 54 \Omega$ or 100Ω
Output Current ⁽⁴⁾				1 -0.8	mA mA	Output disabled, $V_O = 12 V$ $V_O = -7 V$
High Level Input Current	I_{IH}			0.8	mA	
Low Level Input Current	I_{IL}	5	3.5		mA	
Short-circuit Output Current	I_{OS}	60		250	mA	$-7 V < V_O < 12 V$
Supply Current ($V_{DD2} = +5 V$)	I_{DD2}		6	7	mA	No Load
($V_{DD1} = +5 V$)	I_{DD1}		2.5	3	mA	(Outputs Enabled)
Supply Current ($V_{DD1} = +3.3 V$)	I_{DD2}		1.3	2	mA	No Load (Outputs Enabled)

Switching Specifications ($V_{DD1} = +5 V$, $C_{boost} = 16pF$)

Parameters	Symbol	Min.	Typ.	Max.	Units	Test Conditions
Data Rate		5			Mbps	$R_L = 54 \Omega$, $C_L = 50 pF$
Differential Output Prop Delay	$t_D(OD)$		40	65	ns	$R_L = 54 \Omega$, $C_L = 50 pF$
Pulse Skew ⁽¹⁰⁾	$t_{SK}(P)$		6	20	ns	$R_L = 54 \Omega$, $C_L = 50 pF$
Differential Output Rise and Fall Time	$t_T(OD)$	3	12	25	ns	$R_L = 54 \Omega$, $C_L = 50 pF$
Output Enable Time to High Level	t_{PZH}		25	80	ns	$R_L = 54 \Omega$, $C_L = 50 pF$
Output Enable Time to Low Level	t_{PZL}		25	80	ns	$R_L = 54 \Omega$, $C_L = 50 pF$
Output Disable Time from High Level	t_{PHZ}		25	80	ns	$R_L = 54 \Omega$, $C_L = 50 pF$
Output Disable Time from Low Level	t_{PLZ}		25	80	ns	$R_L = 54 \Omega$, $C_L = 50 pF$
Skew Limit ⁽³⁾	$t_{SK}(LIM)$			8	ns	$R_L = 54 \Omega$, $C_L = 50pF$
Common Mode Rejection	$ CM_H , CM_L $	15	20		kV/ μs	$V_T = 300 V_{peak}$

Switching Specifications ($V_{DD1} = +3.3 V$, $C_{boost} = 16pF$)

Parameters	Symbol	Min.	Typ.	Max.	Units	Test Conditions
Data Rate		5			Mbps	$R_L = 54 \Omega$, $C_L = 50 pF$
Differential Output Prop Delay	$t_D(OD)$		40	65	ns	$R_L = 54 \Omega$, $C_L = 50 pF$
Pulse Skew ⁽¹⁰⁾	$t_{SK}(P)$		6	20	ns	$R_L = 54 \Omega$, $C_L = 50 pF$
Differential Output Rise and Fall Time	$t_T(OD)$	3	12	25	ns	$R_L = 54 \Omega$, $C_L = 50 pF$
Output Enable Time to High Level	t_{PZH}		25	80	ns	$R_L = 54 \Omega$, $C_L = 50 pF$
Output Enable Time to Low Level	t_{PZL}		25	80	ns	$R_L = 54 \Omega$, $C_L = 50 pF$
Output Disable Time from High Level	t_{PHZ}		25	80	ns	$R_L = 54 \Omega$, $C_L = 50 pF$
Output Disable Time from Low Level	t_{PLZ}		25	80	ns	$R_L = 54 \Omega$, $C_L = 50 pF$
Skew Limit ⁽³⁾	$t_{SK}(LIM)$			8	ns	$R_L = 54 \Omega$, $C_L = 50pF$
Common Mode Rejection	$ CM_H , CM_L $	15	20		kV/ μs	$V_T = 300 V_{peak}$

Receiver Section

Electrical specifications are T_{min} to T_{max} unless otherwise stated.

Parameters	Symbol	Min.	Typ.	Max.	Units	Test Conditions
Coil Input Impedance	Z_{COIL}		85 9		ΩnH	$T_{AMB} = 25^{\circ}C$ $V_{DD} = 3.0 V$ to 5.5 V
Temperature Coefficient of Coil Resistance	TC R_{COIL}		0.2	0.25	$\Omega/^{\circ}C$	$V_{DD} = 3.0 V$ to 5.5 V
Positive-going Input Threshold	V_{IT+}			0.2	V	$-7 V < V_{CM} < 12 V$
Negative-going Input Threshold	V_{IT-}	-0.2			V	$-7 V < V_{CM} < 12 V$
Hysteresis Voltage ($V_{it+} - V_{it-}$)	V_{HYS}		70		mV	$V_{CM} = 0V, T = 25^{\circ}C$
High Level Digital Output Voltage	V_{OH}	$V_{DD} - 0.2$	$V_{DD} - 0.2$		V	$V_{ID} = 200 mV$ $I_{OH} = 4 mA$
Low Level Digital Output Voltage	V_{OL}			0.8	V	$V_{ID} = -200 mV$ $I_{OL} = 4 mA$
High impedance state output current	I_{OZ}			10	μA	$0.4 \leq V_{O} \leq (V_{DD2} - 0.5) V$
Line Input Current ⁽⁸⁾	I_I			1	mA	$V_I = 12 V$
				-0.8		$V_I = -7 V$
Input Resistance	r_I	96			k Ω	
Switching Characteristics. ($V_{DD1} = +5 V, C_{boost} = 16pF$)						
Parameters	Symbol	Min.	Typ.	Max.	Units	Test Conditions
Data Rate		5			Mbps	$R_L = 54 \Omega, C_L = 50 pF$
Propagation Delay ⁽⁹⁾	t_{PD}		90	150	ns	$-1.5 \leq V_O \leq 1.5 V,$ $C_L = 15 pF$
Pulse Skew ⁽¹⁰⁾	$t_{SK}(P)$		6	20	ns	$-1.5 \leq V_O \leq 1.5 V,$ $C_L = 15 pF$
Skew Limit ⁽³⁾	$t_{SK}(LIM)$		2	8	ns	$R_L = 54 \Omega, C_L = 50 pF$
Output Enable Time to High Level	t_{PZH}		4	10	ns	$C_L = 15 pF$
Output Enable Time to Low Level	t_{PZL}		4	10	ns	$C_L = 15 pF$
Output Disable Time from High Level	t_{PHZ}		4	10	ns	$C_L = 15 pF$
Output Disable Time from Low Level	t_{PLZ}		4	10	ns	$C_L = 15 pF$
Switching Characteristics. ($V_{DD1} = +3.3 V, C_{boost} = 16pF$)						
Parameters	Symbol	Min.	Typ.	Max.	Units	Test Conditions
Data Rate		5			Mbps	$R_L = 54 \Omega, C_L = 50 pF$
Propagation Delay ⁽⁹⁾	t_{PD}		100	150	ns	$-1.5 \leq V_O \leq 1.5 V,$ $C_L = 15 pF$
Pulse Skew ⁽¹⁰⁾	$t_{SK}(P)$		10	20	ns	$-1.5 \leq V_O \leq 1.5 V,$ $C_L = 15 pF$
Skew Limit ⁽³⁾	$t_{SK}(LIM)$		4	10	ns	$R_L = 54 \Omega, C_L = 50 pF$
Output Enable Time to High Level	t_{PZH}		5	10	ns	$C_L = 15 pF$
Output Enable Time to Low Level	t_{PZL}		5	10	ns	$C_L = 15 pF$
Output Disable Time from High Level	t_{PHZ}		5	10	ns	$C_L = 15 pF$
Output Disable Time from Low Level	t_{PLZ}		17	10	ns	$C_L = 15 pF$

Notes (apply to both driver and receiver sections):

- All voltage values are with respect to network ground except differential I/O bus voltages.
- Differential input/output voltage is measured at the non-inverting terminal A with respect to the inverting terminal B.
- Skew limit is the maximum difference in any two channels in one device.
- The power-off measurement in ANSI Standard EIA/TIA-422-B applies to disabled outputs only and is not applied to combined inputs and outputs.
- All typical values are at $V_{DD1}, V_{DD2} = 5 V$ or $V_{DD1} = 3.3 V$ and $T_A = 25^{\circ}C$.
- While $-7 V < V_{CM} < 12 V$, the minimum V_{OD2} with a 54 Ω load is either $\frac{1}{2} V_{OD1}$ or 1.5 V, whichever is greater.
- $\Delta|V_{OD}|$ and $\Delta|V_{OC}|$ are the changes in magnitude of V_{OD} and V_{OC} , respectively, that occur when the input is changed from one logic state to the other.
- This applies for both power on and power off; refer to ANSI standard RS-485 for exact condition. The EIA/TIA-422-B limit does not apply for a combined driver and receiver terminal.
- Includes 10 ns read enable time. Maximum propagation delay is 25 ns after read assertion.
- Pulse skew is defined as the $|t_{PLH} - t_{PHL}|$ of each channel.

Power Supply Decoupling

Both V_{DD1} and V_{DD2} must be bypassed with 47 nF ceramic capacitors. These should be placed as close as possible to V_{DD} pins for proper operation. Additionally, V_{DD2} should be bypassed with a 10 μ F tantalum capacitor.

Operation

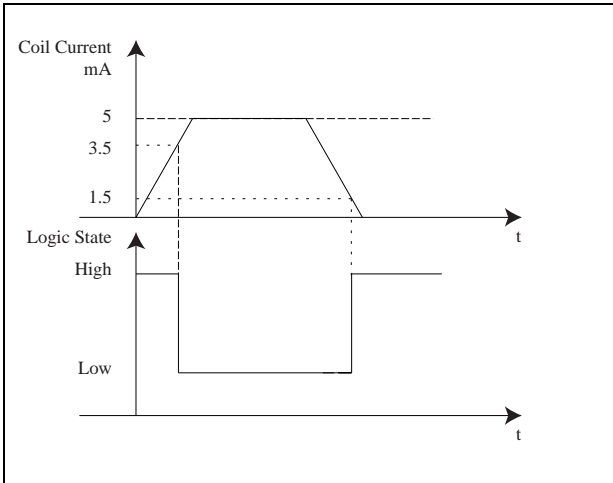

Figure 1. IL3000 Series Input Transfer Function

The IL3222 and IL3285 are current-mode devices. Changes in input coil current switch internal spintronic GMR sensors, which then change the logic state of the outputs. The GMR bridge is designed so the output of the isolator is logic high when no field signal is present.

A single resistor is required to limit the input coil current to the recommended 5 mA. The absolute maximum current through any coil is 25 mA DC. Although logic threshold currents are typically less than the worst-case 5 mA, NVE recommends designing for 5 mA logic threshold current in all applications.

Figure 1 shows the input response of the IL3222 and IL3285. Output logic high is the zero input current state. The output switches to the low state with approximately 3.5 mA of coil current, and back to the high state when the input current falls below approximately 1.5 mA. This allows glitch-free interface with low slew-rate signals.

Typical Resistor Values

V_{COIL}	0.125W, 5% Resistor
3.3 V	510 Ω
5 V	820 Ω

The table shows typical values for the external resistor in 5 V and 3 V logic systems. As always, these values are approximate and should be adjusted for temperature or other application specifics. If the expected temperature range is large, 1% tolerance resistors may provide additional design margin.

Boost Capacitor

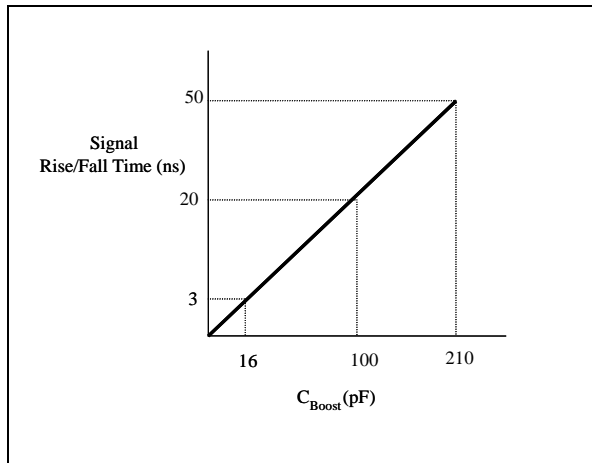

Figure 2. C_{boost} Selector

The boost capacitor in parallel with the current-limiting resistor boosts the instantaneous coil current at the signal transition. The boost current pushes the GMR bridge output through the comparator threshold voltage in a bipolar fashion providing important magnetic centering and very reliable switching. **Select the value of the boost capacitor based on the rise and fall times of the signal driving the inputs.**

Use the chart as a guide to boost capacitor selection. The capacitor value is generally not critical, and can often vary $\pm 50\%$ with little noticeable difference in device performance provided the center value is correct. If in doubt, choose a value higher than indicated, up to a maximum of 470 nF. Note however that power dissipation in the input coil increases in proportion to the capacitor value.

The correct boost capacitor gives a great deal of design headroom and can usually eliminate design concerns related to temperature and power supply fluctuations.

Magnetic Field Immunity

IsoLoop devices operate by imposing a magnetic field on a GMR sensor, which translates the change in field into a change in logic state. The devices are manufactured with a magnetic shield above the sensor. The shield acts as a flux concentrator to boost the magnetic signal from the internal coil, and as a shield against external magnetic fields. The shield absorbs surrounding stray flux until it becomes saturated. At saturation the shield is transparent to external applied fields, and the GMR sensor may react to the field. To compensate for this effect, IsoLoop Isolators use Wheatstone Bridge structures that are only sensitive to differential magnetic fields. There are several ways to further enhanced the magnetic field immunity of IL3000 Transceivers. Providing a larger internal field will reduce the effect of an external field on the GMR sensor. Immunity to external magnetic fields can also be enhanced by proper orientation of the device with respect to the field direction and field boosting capacitors.

Orientation of the device with respect to the field direction

An applied field in the “H1” direction is the worst case for magnetic immunity. In this case the external field is in the same

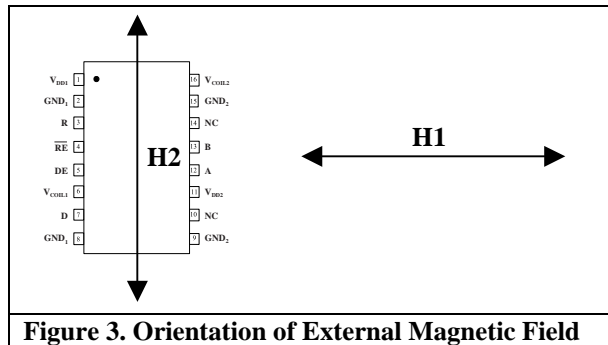

direction as the applied internal field. In one direction it will tend to help switching; in the other it will hinder switching. This can cause unpredictable operation.

An applied field in the direction of “H2” has considerably less effect on the sensor and will result in significantly higher immunity levels as shown in Table 1.

The greatest magnetic immunity is achieved by adding the current boost capacitor across the input resistor. Very high immunity can be achieved with this method.

Figure 3. Orientation of External Magnetic Field

Method	Approximate Immunity	Immunity Description
Field applied in direction H1	±20 Gauss	A DC current of 16 A flowing in a conductor 1 cm from the device could cause disturbance
Field applied in direction H2	±70 Gauss	A DC current of 56 A flowing in a conductor 1 cm from the device could cause disturbance
Field applied in any direction but with field booster capacitor (470 pF) in circuit	±250 Gauss	A DC current of 200 A flowing in a conductor 1 cm from the device could cause disturbance

Table 1. Magnetic Immunity

Data Rate and Magnetic Field Immunity

It is easier to disrupt an isolated DC signal with an external magnetic field than it is to disrupt an isolated AC signal. Similarly, a DC magnetic field will have a greater effect on the device than an AC magnetic field of the same effective magnitude. For example, signals with pulses greater than 100 μs long are more susceptible to magnetic fields than shorter pulse widths. For input signals faster than 1 MHz, rising in less than 3 ns, a 470 pF field-boost capacitor provides as much as 400 Gauss immunity, while the same input capacitor might provide just 70 Gauss of immunity at 50 kHz.

Applications Information

RS-485 and RS-422 are differential (balanced) data transmission standards for use over long distances or in noisy environments. RS-422 is an RS-485 subset, so RS-485 transceivers are also RS-422-compliant. RS-422 is a multi-drop standard allowing only one driver and up to 10 receivers on each bus (assuming unit load receivers). RS-485 is a true multipoint standard which allows up to 32 unit load devices (any combination of drivers and receivers) on each bus. To allow for multipoint operation, RS-485 requires drivers to handle bus contention without damage. Another important advantage of RS-485 is the extended common-mode range (CMR), which requires driver outputs and receiver inputs withstand +12 V to -7 V. RS-422 and RS-485 are intended for runs as long as 4,000 feet (1,200 m), so the wide CMR is necessary for ground potential differences, as well as voltages induced in the cable by external fields.

Receiver Features

IL3000 transceivers have differential input receivers for maximum noise immunity and common-mode rejection. Input sensitivity is ± 200 mV as required by the RS-422 and RS-485 specifications. The receivers include a “fail-safe if open” function that guarantees a high level receiver output if the receiver inputs are unconnected (floating). Receivers easily meet the data rates supported by the corresponding driver. IL3000-Series receiver outputs have tri-state capabilities with active low RE inputs.

Driver Features

The RS485/422 driver is a differential output device that delivers at least 1.5 V across a 54 Ω load (RS-485), and at least 2 V across a 100 Ω load (RS-422). The driver features low propagation delay skew to maximize bit width and minimize EMI. IL3222 and IL3285 drivers have tri-state capability with an active high DE input.

Cabling, Data Rate and Terminations

Cabling:

Use twisted-pair cable. The cable can be unshielded if it is short (<10 m) and the data rate is slow (<100 Kbps). Otherwise, use screened cable with the shield tied to earth ground at one end only. Do not tie the shield to digital ground. The other end of the shield may be tied to earth ground through an RC network. This prevents a DC ground loop in the shield. Shielded cable minimizes EMI emissions and external noise coupling to the bus.

Data Rate:

The longer the cable, the slower the data rate. The RS-485 bus can transmit ground over 4,000 feet (1,200 m) or at 10Mbps, but not both at the same time. Transducer and cable characteristics combine to act as a filter with the general response shown in Figure 4. Other parameters such as acceptable jitter affect the final cable length versus data rate tradeoff. Less jitter means better signal quality but shorter cable lengths or slower data rates. Figure 4 shows a generally accepted 30% jitter and a corresponding data rate versus cable length.

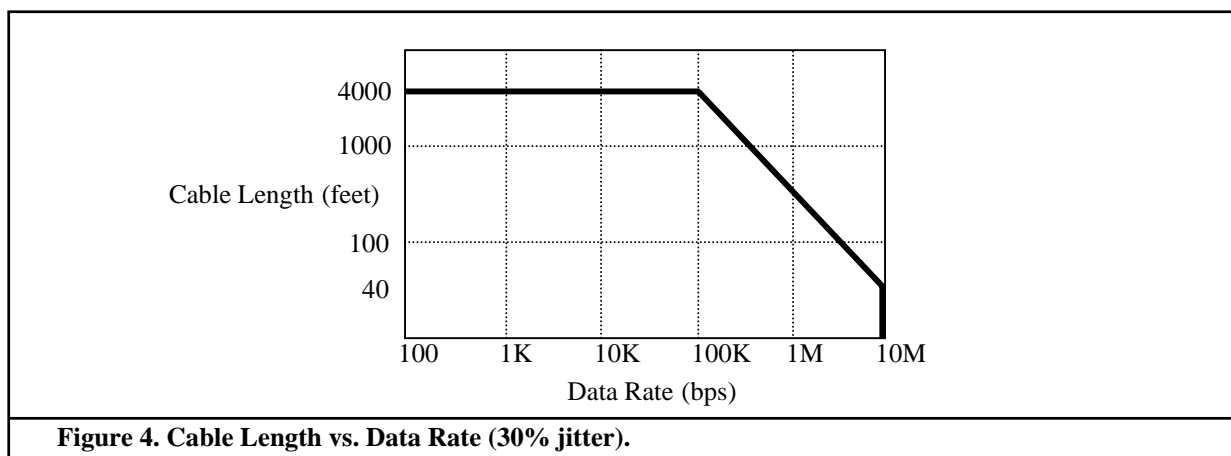

Terminations:

Transmission lines should be terminated to avoid reflections that cause data errors. In RS-485 systems both ends of the bus, not every node, should be terminated. In RS-422 systems only the receiver end should be terminated.

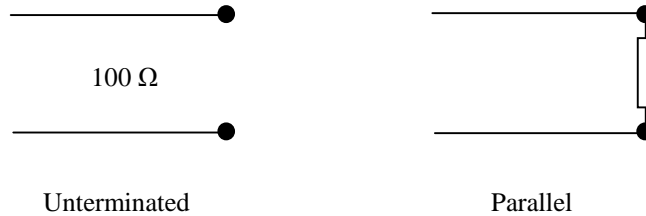

Proper termination is imperative when using IL3285 and IL3222 to minimize reflections. Unterminated lines are only suitable for very low data rates and very short cable runs, otherwise line reflections cause problems. Parallel terminations are the most popular. They allow high data rates and excellent signal quality.

Occasionally in noisy environments, fast pulses or noise appearing on the bus lines cause errors. One way of alleviating such errors without adding circuit delays is to place a series resistor in the bus line. Depending on the power supply, the resistor should be between 300 Ω (3 V supply) and 500 Ω (5 V supply).

Typical Coil Connections	
$V_{DD1} = V_{DD2} = 5\text{ V}$ $V_{DD1} = 3.3\text{ V}$	$R1, R2, R3 = 820\ \Omega$ $R1, R2 = 510\ \Omega; R3 = 820\ \Omega$
$V_{DD1} = V_{DD2} = 5\text{ V}$ $V_{DD1} = 3.3\text{ V}$	$R1, R2, R3 = 820\ \Omega$ $R1, R2 = 510\ \Omega; R3 = 820\ \Omega$

Fail-Safe Operation:

“Fail-safe operation” is defined here as the forcing of a logic high state on the “R” output in response to an open-circuit condition between the “A” and “B” lines of the bus, or when no drivers are active on the bus.

Proper biasing can ensure fail-safe operation, that is a known state when there are no active drivers on the bus. IL3285 and IL3222 Isolated Transceivers include internal pull-up and pull-down resistors of approximately 200 kΩ in the receiver section (R_{FS-INT} ; see figure below). These internal resistors are designed to ensure failsafe operation but only if there are no termination resistors. The entire V_{DD} will appear between inputs “A” and “B” if there is no loading and no termination resistors, and there will be more than the required 200 mV with up to four RS-485/RS-422 worst-case one-eighth unit loads of 96 kΩ. Many designs operating below 1 Mbps or less than 1,000 feet are unterminated. Termination resistors may not be necessary for very low data rates and very short cable runs because reflections have time to settle before data sampling, which occurs at the middle of the bit interval.

In busses with low-impedance termination resistors, however, the differential voltage across the conductor pair will be close to zero with no active drivers. In this case the state of the bus is indeterminate, and the idle bus will be susceptible to noise. For example, with 120 Ω termination resistors (R_T) on each end of the cable, and four eighth unit loads (96 kΩ each), without external fail-safe biasing resistors the internal pull-up and pull-down resistors will produce a voltage between inputs “A” and “B” of only about one millivolt. This is not nearly enough to ensure a known state. External fail-safe biasing resistors (R_{FS-EXT}) at one end of the bus can ensure fail-safe operation with a terminated bus. Resistors should be selected so that under worst-case power supply and resistor tolerances there is at least 200 mV across the conductor pair with no active drivers to meet the input sensitivity specification of the RS-422 and RS-485 standards.

Using the same value for pull-up and pull-down biasing resistors maintains balance for positive- and negative going transitions. Lower-value resistors increase inactive noise immunity at the expense of quiescent power consumption. Note that each Unit Load on the bus adds a worst-case loading of 12 kΩ across the conductor pair, and 256 one-eighth unit loads add 375 Ω worst-case loading. The more loads on the bus, the lower the required values of the biasing resistors.

In the example with two 120 Ω termination resistors and four eighth unit loads, 560 Ω external biasing resistors provide more than 200 mV between “A” and “B” with adequate margin for power supply variations and resistor tolerances. This ensures a known state when there are no active drivers. Other illustrative examples are shown in the table below.

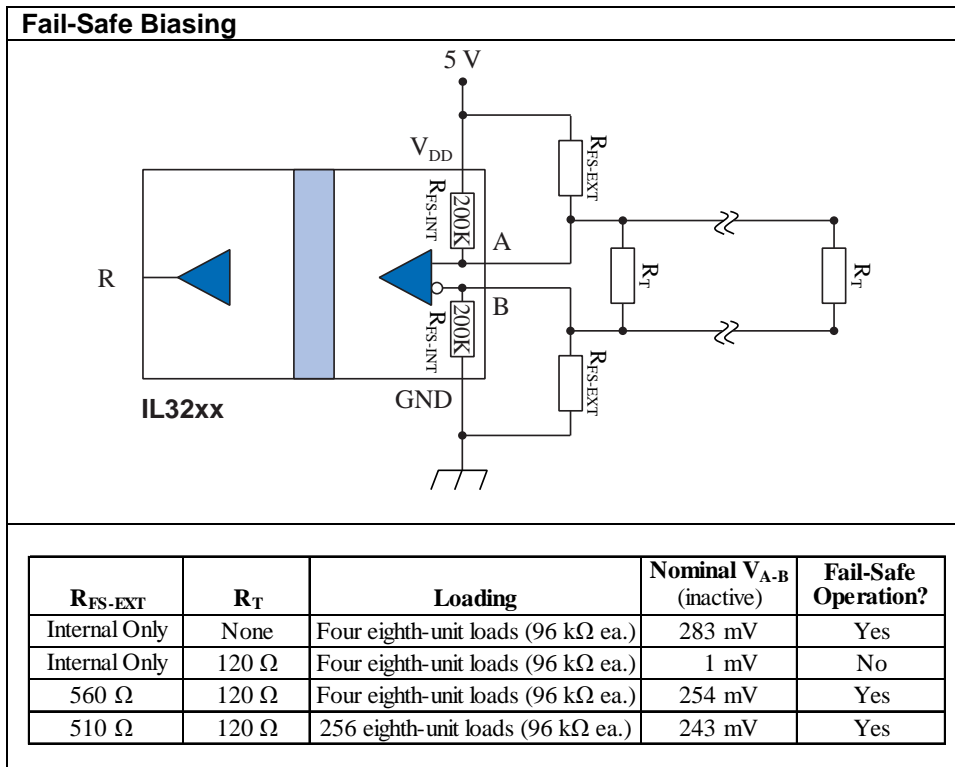

Package Drawings, Dimensions and Specifications

0.15" 16-pin SOIC

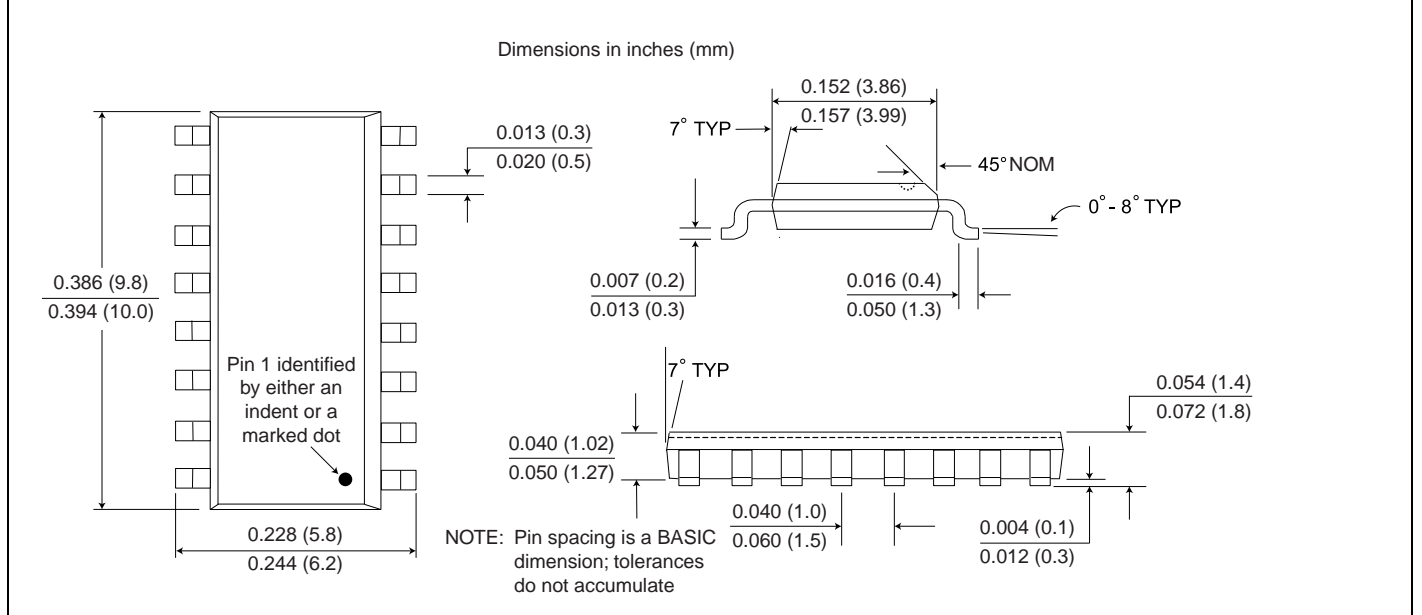

0.3" 16-pin SOIC

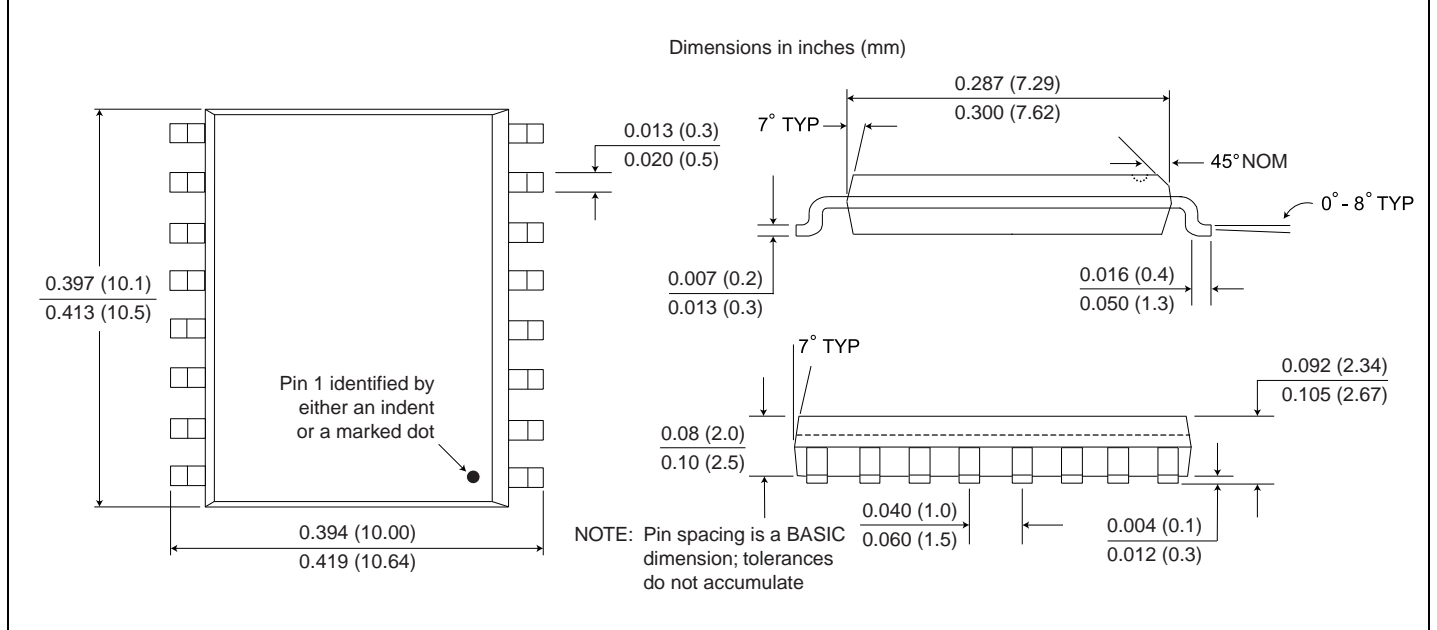

Ordering Information and Valid Part Numbers

IL 32 85 -3 E TR13

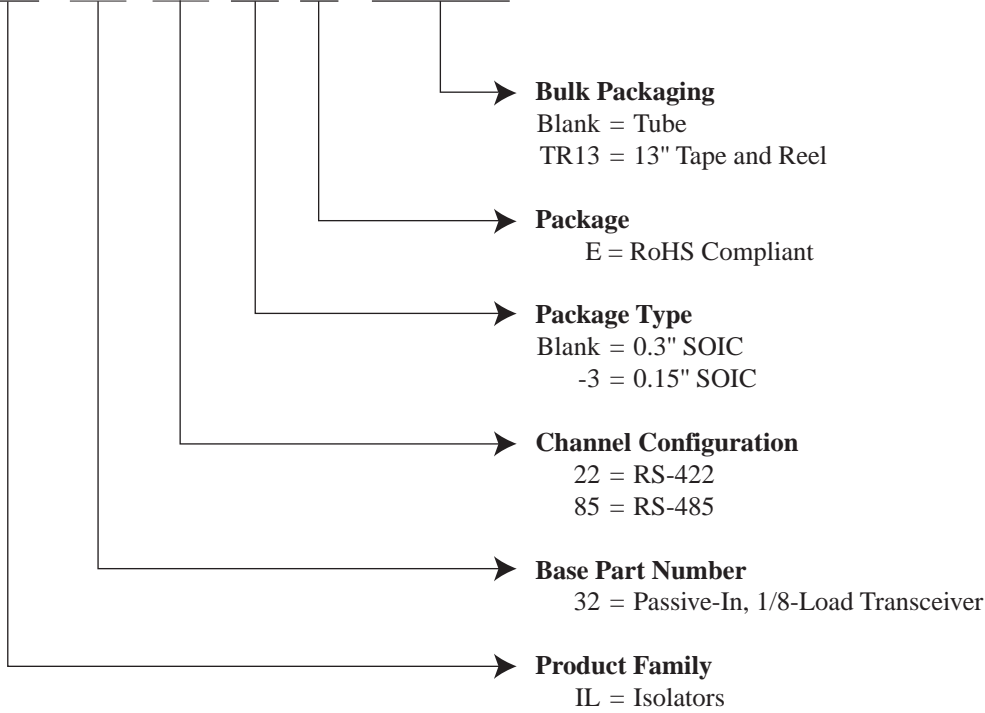

Valid Part Numbers

- IL3285E
- IL3285E TR13
- IL3285-3E
- IL3285-3E TR13

- IL3222E
- IL3222E TR13
- IL3222-3E
- IL3222-3E TR13



Revision History

ISB-DS-001-IL3185/22-K
August 2009

Changes

- Changes to current-limiting resistor values (pp. 7 and 10).
- Details for boost capacitor selection (p. 7).

ISB-DS-001-IL3285/22-J

Change

- Noted UL1577 Approval.

ISB-DS-001-IL3285/22-I

Change

- Added bus-protection ESD specification (15 kV).

ISB-DS-001-IL3285/22-H

Changes

- Added typical coil resistance and temperature coefficient specifications.
- Added note on package drawings that pin-spacing tolerances are non-accumulating.

ISB-DS-001-IL3285/22-G

Changes

- Changed ordering information to reflect that devices are now fully RoHS compliant with no exemptions.

ISB-DS-001-IL3285/22-F

Changes

- Eliminated soldering profile chart

ISB-DS-001-IL3285/22-E

Changes

- Separate pinout diagrams for narrow- and wide-body packages

ISB-DS-001-IL3285/22-D

Changes

- Added “Open” input condition to truth tables
- Fail-safe biasing section added
- Narrow-body SOIC packages added

ISB-DS-001-IL3285/22-C

Changes

1. Capacitor Information added on page 1
2. Input Signal Rise/Fall times changed from 10 μ s to 1 μ s
3. Typical coil formations show C_{Boost}
4. Switching characteristics show $C_{Boost} = 16$ pF

ISB-DS-001-IL3285/22-B

Revision A not released

ISB-DS-001-IL3285/22-A

Internal Release ONLY

About NVE

An ISO 9001 Certified Company

NVE Corporation manufactures innovative products based on unique spintronic Giant Magnetoresistive (GMR) technology. Products include Magnetic Field Sensors, Magnetic Field Gradient Sensors (Gradiometers), Digital Magnetic Field Sensors, Digital Signal Isolators, and Isolated Bus Transceivers.

NVE pioneered spintronics and in 1994 introduced the world's first products using GMR material, a line of ultra-precise magnetic sensors for position, magnetic media, gear speed and current sensing.

NVE Corporation
11409 Valley View Road
Eden Prairie, MN 55344-3617 USA
Telephone: (952) 829-9217
Fax: (952) 829-9189
Internet: www.nve.com
e-mail: isoinfo@nve.com

The information provided by NVE Corporation is believed to be accurate. However, no responsibility is assumed by NVE Corporation for its use, nor for any infringement of patents, nor rights or licenses granted to third parties, which may result from its use. No license is granted by implication, or otherwise, under any patent or patent rights of NVE Corporation. NVE Corporation does not authorize, nor warrant, any NVE Corporation product for use in life support devices or systems or other critical applications, without the express written approval of the President of NVE Corporation.

Specifications are subject to change without notice.

ISB-DS-001-IL3285/22-K
August 2009