

**Silicon N-Channel MOSFET**

**Features**

- 1A,600V, RDS(on)(Max 15.0Ω)@VGS=10V
- Ultra-low Gate Charge(Typical 6.1nC)
- Fast Switching Capability
- 100%Avalanche Tested
- Maximum Junction Temperature Range(150°C)

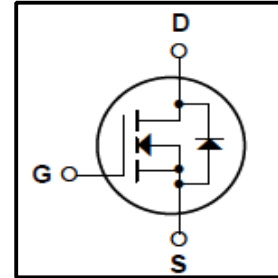

**General Description**

This Power MOSFET is produced using Winsemi's advanced planar stripe, VDMOS technology. This latest technology has been especially designed to minimize on-state resistance, have a high rugged avalanche characteristics. This devices is specially well suited for high efficiency switch mode power supply. electronic Lamp ballasts based on half bridge and UPS.

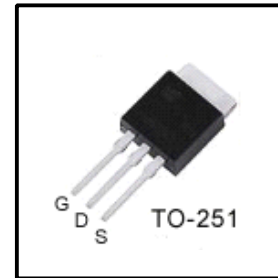

**Absolute Maximum Ratings**

Symbol	Parameter	Value	Units
V <sub>DSS</sub>	Drain Source Voltage	600	V
I <sub>D</sub>	Continuous Drain Current(@Tc=25°C)	1.0	A
	Continuous Drain Current(@Tc=100°C)	0.62	A
I <sub>DM</sub>	Drain Current Pulsed (Note1)	4.0	A
V <sub>GS</sub>	Gate to Source Voltage	±30	V
E <sub>AS</sub>	Single Pulsed Avalanche Energy (Note 2)	47	mJ
E <sub>AR</sub>	Repetitive Avalanche Energy (Note 1)	3.1	mJ
dv/dt	Peak Diode Recovery dv/dt (Note 3)	4.5	V/ns
P <sub>D</sub>	Total Power Dissipation(@Tc=25°C)	30	W
	Derating Factor above 25°C	0.24	W/°C
T <sub>J</sub> , T <sub>stg</sub>	Junction and Storage Temperature	-55~150	°C
T <sub>L</sub>	Channel Temperature	300	°C

**Thermal Characteristics**

Symbol	Parameter	Value			Units
		Min	Typ	Max	
R <sub>QJC</sub>	Thermal Resistance, Junction-to-Case	-	-	4.16	°C/W
R <sub>QCS</sub>	Thermal Resistance, Case-to-Sink	0.5	-	-	°C/W
R <sub>QJA</sub>	Thermal Resistance, Junction-to-Ambient	-	-	105	°C/W

## Electrical Characteristics (T<sub>c</sub> = 25 °C)

Characteristics	Symbol	Test Condition	Min	Type	Max	Unit	
Gate leakage current	I <sub>GSS</sub>	V <sub>GS</sub> = ±30 V, V <sub>DS</sub> = 0 V	-	-	±100	nA	
Gate-source breakdown voltage	V <sub>(BR)GSS</sub>	I <sub>G</sub> = ±10 μA, V <sub>DS</sub> = 0 V	±30	-	-	V	
Drain cut-off current	I <sub>DSS</sub>	V <sub>DS</sub> = 600 V, V <sub>GS</sub> = 0 V	-	-	10	μA	
		V <sub>DS</sub> = 480 V, T <sub>c</sub> = 125 °C	-	-	100	μA	
Drain-source breakdown voltage	V <sub>(BR)DSS</sub>	I <sub>D</sub> = 250 μA, V <sub>GS</sub> = 0 V	600	-	-	V	
Break Voltage Temperature Coefficient	ΔBV <sub>DSS</sub> /ΔT <sub>J</sub>	I <sub>D</sub> =250μA, Referenced to 25 °C	-	0.5	-	V/°C	
Gate threshold voltage	V <sub>GS(th)</sub>	V <sub>DS</sub> = 10 V, I <sub>D</sub> = 250 μA	2	-	4	V	
Drain-source ON resistance	R <sub>DS(ON)</sub>	V <sub>GS</sub> = 10 V, I <sub>D</sub> = 0.5A	-	11	15	Ω	
Forward Transconductance	g <sub>fs</sub>	V <sub>DS</sub> = 50 V, I <sub>D</sub> = 0.5A	-	0.8	-	S	
Input capacitance	C <sub>iss</sub>	V <sub>DS</sub> = 25 V,	-	178	221	pF	
Reverse transfer capacitance	C <sub>rss</sub>	V <sub>GS</sub> = 0 V,	-	4	5		
Output capacitance	C <sub>oss</sub>	f = 1 MHz	-	19	27		
Switching time	Rise time	t <sub>r</sub>	V <sub>DD</sub> = 300 V, I <sub>D</sub> = 1A R <sub>G</sub> = 25Ω (Note 4,5)	-	15	45	ns
	Turn-on time	t <sub>on</sub>		-	46	105	
	Fall time	t <sub>f</sub>		-	26	62	
	Turn-off time	t <sub>off</sub>		-	37	82	
Total gate charge (gate-source plus gate-drain)	Q <sub>g</sub>	V <sub>DD</sub> = 4.80 V, V <sub>GS</sub> = 10 V, I <sub>D</sub> = 1 A (Note 4,5)	-	6.1	7.2	nC	
Gate-source charge	Q <sub>gs</sub>		-	1.0	-		
Gate-drain ("miller") Charge	Q <sub>gd</sub>		-	3.0	-		

## Source-Drain Ratings and Characteristics (T<sub>a</sub> = 25 °C)

Characteristics	Symbol	Test Condition	Min	Type	Max	Unit
Continuous drain reverse current	I <sub>DR</sub>	-	-	-	1.0	A
Pulse drain reverse current	I <sub>DRP</sub>	-	-	-	4.0	A
Forward voltage (diode)	V <sub>DSF</sub>	I <sub>DR</sub> = 1A, V <sub>GS</sub> = 0 V	-	-	1.0	V
Reverse recovery time	t <sub>rr</sub>	I <sub>DR</sub> = 1A, V <sub>GS</sub> = 0 V,	-	185	-	ns
Reverse recovery charge	Q <sub>rr</sub>	dI <sub>DR</sub> / dt = 100 A / μs	-	0.51	-	μC

Note 1. Repeatability rating : pulse width limited by junction temperature

2. L=59mH, I<sub>AS</sub>=1A, V<sub>DD</sub>=50V, R<sub>G</sub>=25Ω, Starting T<sub>J</sub>=25°C

3. I<sub>SD</sub>≤1A, di/dt≤200A/us, V<sub>DD</sub><BV<sub>DSS</sub>, STARTING T<sub>J</sub>=25°C

4. Pulse Test: Pulse Width≤300us, Duty Cycle≤2%

5. Essentially independent of operating temperature.

This transistor is an electrostatic sensitive device

Please handle with caution

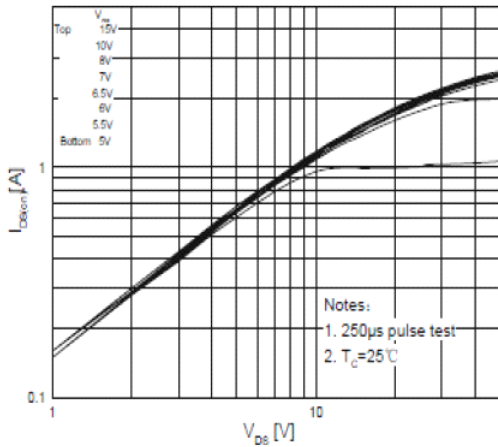

**Fig. 1 On-State Characteristics**

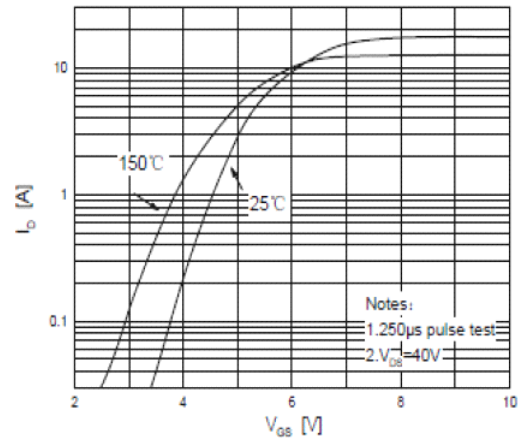

**Fig. 2 Transfer Current Characteristics**

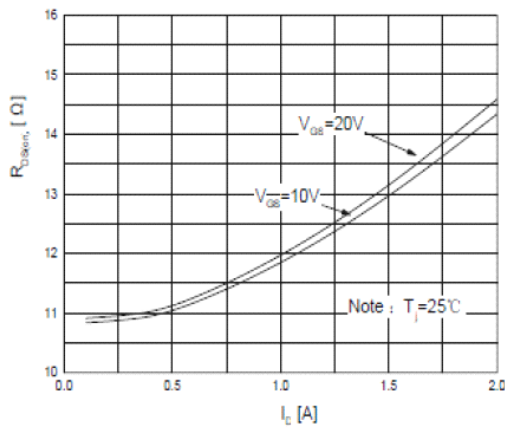

**Fig. 3 On-Resistance Variation vs Drain Current**

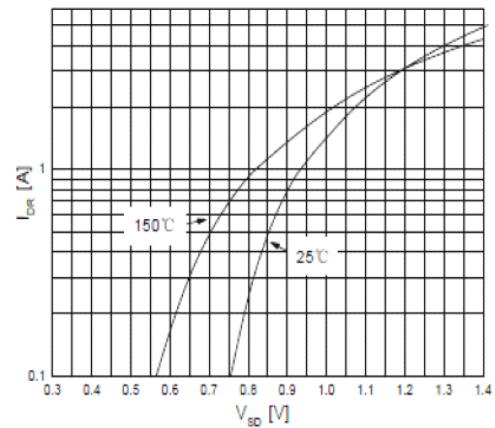

**Figure 4. Body Diode Forward Voltage Variation with Source Current and Temperature**

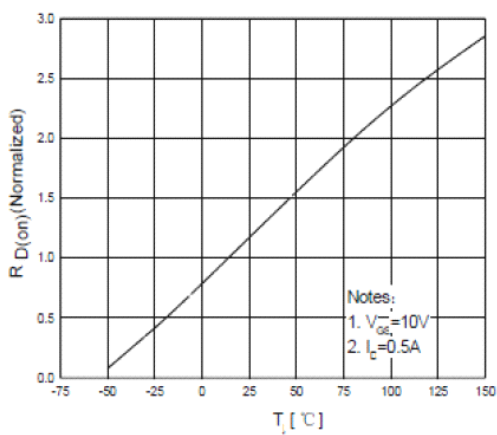

**Fig. 5 On-Resistance Variation vs Junction Temperature**

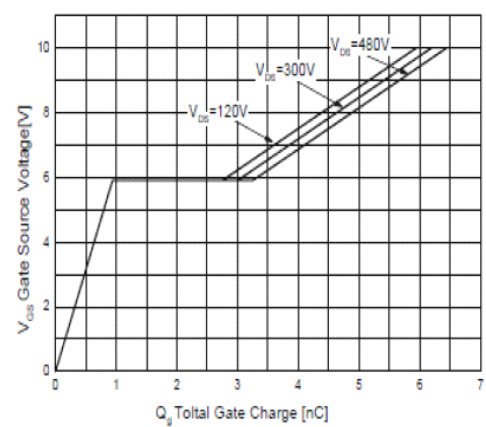

**Fig. 6 Gate Charge Characteristics**

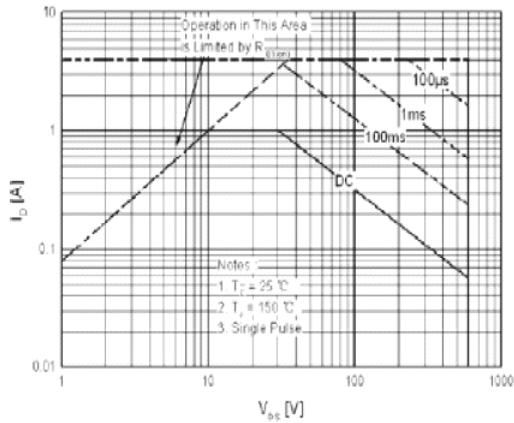

**Fig.7 Maximum Safe Operation Area**

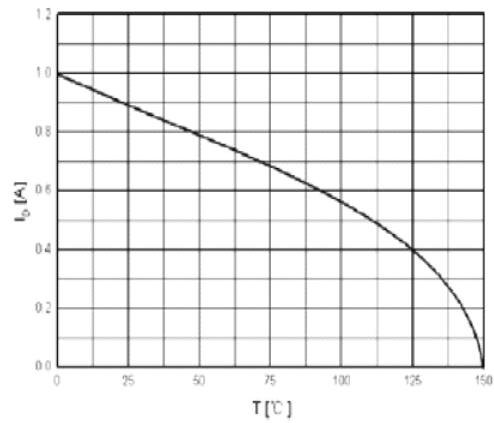

**Fig.8 Maximum Drain Current vs Case Temperature**

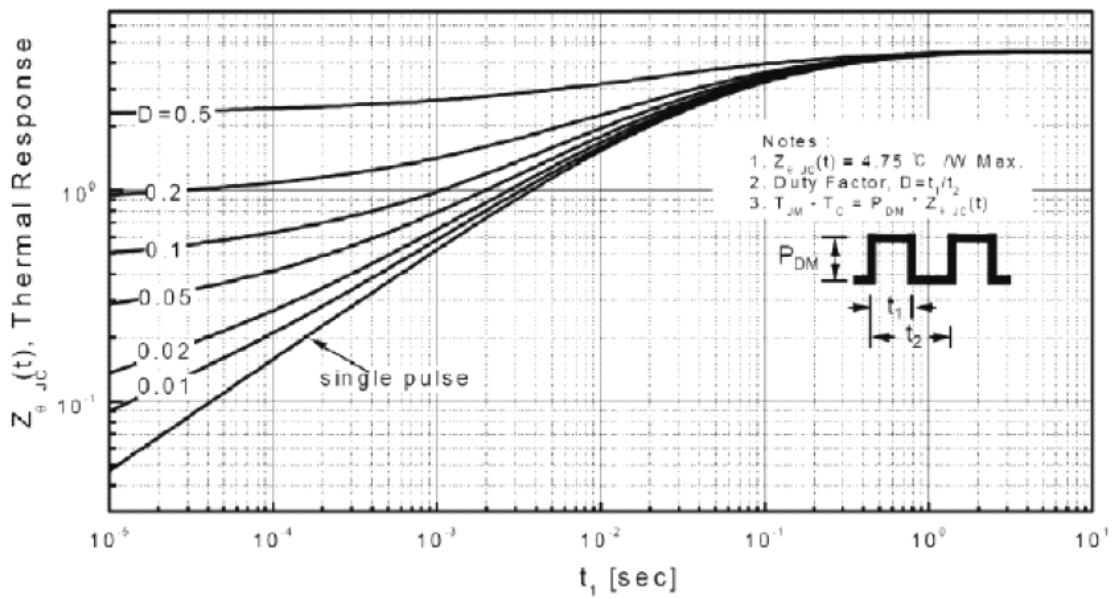

**Fig.9 Transient Thermal Response Curve**

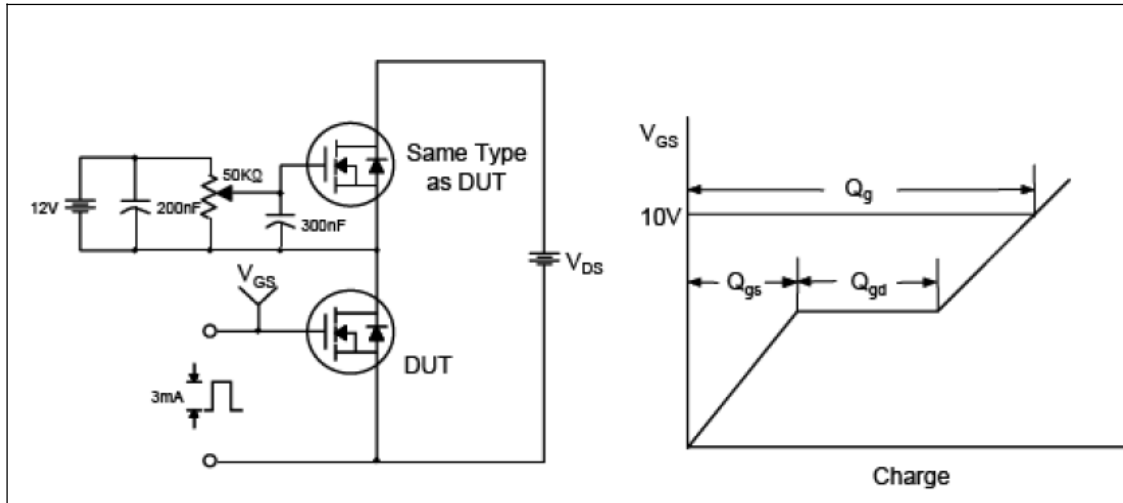

**Fig.10 Gate Test Circuit & Waveform**

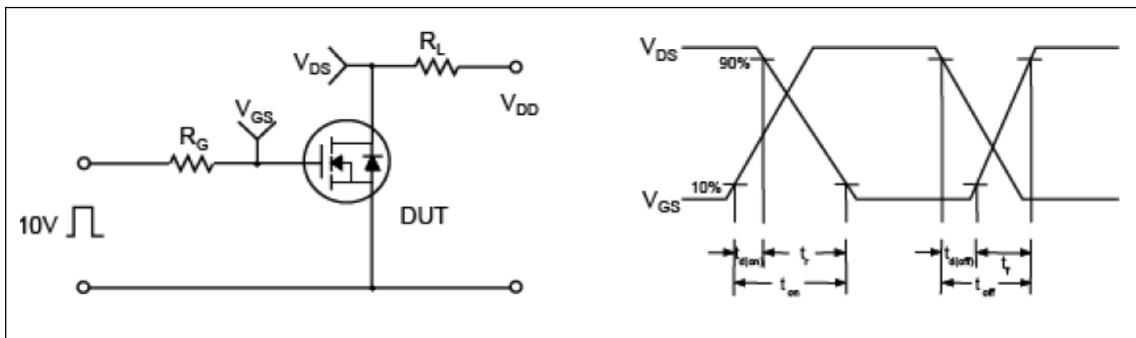

**Fig.11 Resistive Switching Test Circuit & Waveform**

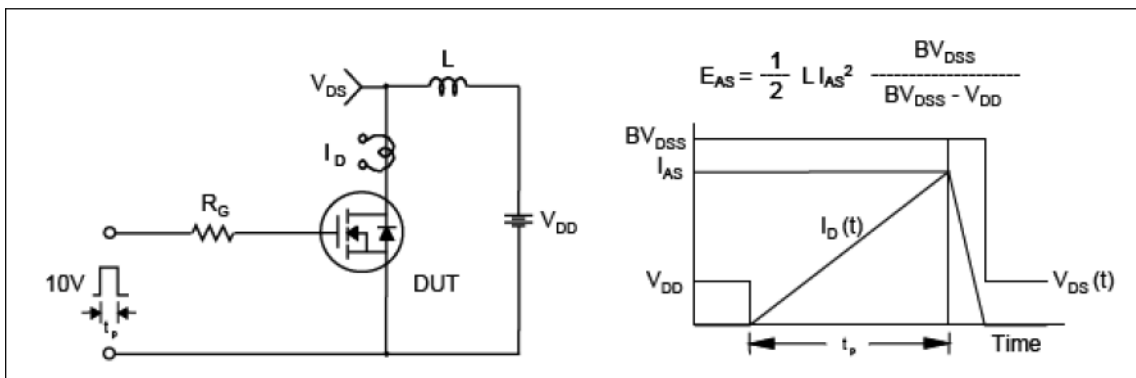

**Fig.12 Unclamped Inductive Switching Test Circuit & Waveform**

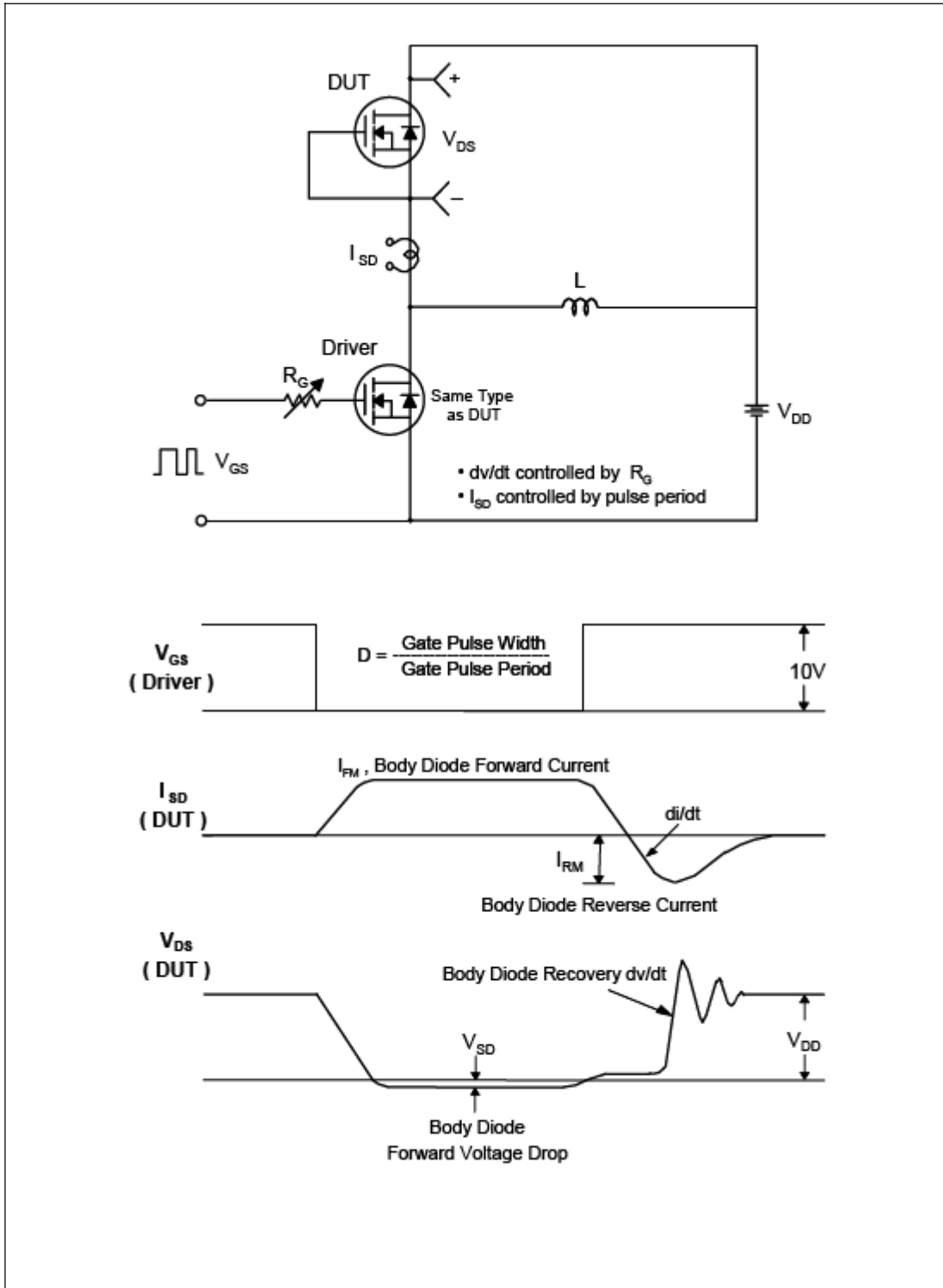

**Fig.13 Peak Diode Recovery  $dv/dt$  Test Circuit & Waveform**

**TO251 Package Dimension**

Unit: mm

