

5150 PIXELS CCD LINEAR IMAGE SENSOR

DESCRIPTION

The μ PD3737 is a 5150-pixel high sensitivity CCD (Charge Coupled Device) linear image sensor which changes optical images to electrical signal.

The μ PD3737 has high speed CCD register, so it is suitable for high resolution scanners and facsimiles which scan high definition document at high speed.

FEATURES

- Valid photocell : 5150 pixels
- Photocell pitch : 7 μ m
- High response sensitivity
- Peak response wavelength : 550 nm (green)
- Resolution : 16 dot/mm A3 (297 \times 420 mm) size (shorter side)
24 dot/mm A4 (210 \times 297 mm) size (shorter side)
- High speed scan : 252 μ s/line
- Drive clock level : CMOS output under +5 V operation
- Data rate : 20 MHz Max.
- Power supply : +12 V

ORDERING INFORMATION

Part Number	Package
★ μ PD3737CY	CCD linear image sensor 32-pin plastic DIP (10.16 mm (400))

The information in this document is subject to change without notice. Before using this document, please confirm that this is the latest version.

Not all products and/or types are available in every country. Please check with an NEC Electronics sales representative for availability and additional information.

★ BLOCK DIAGRAM

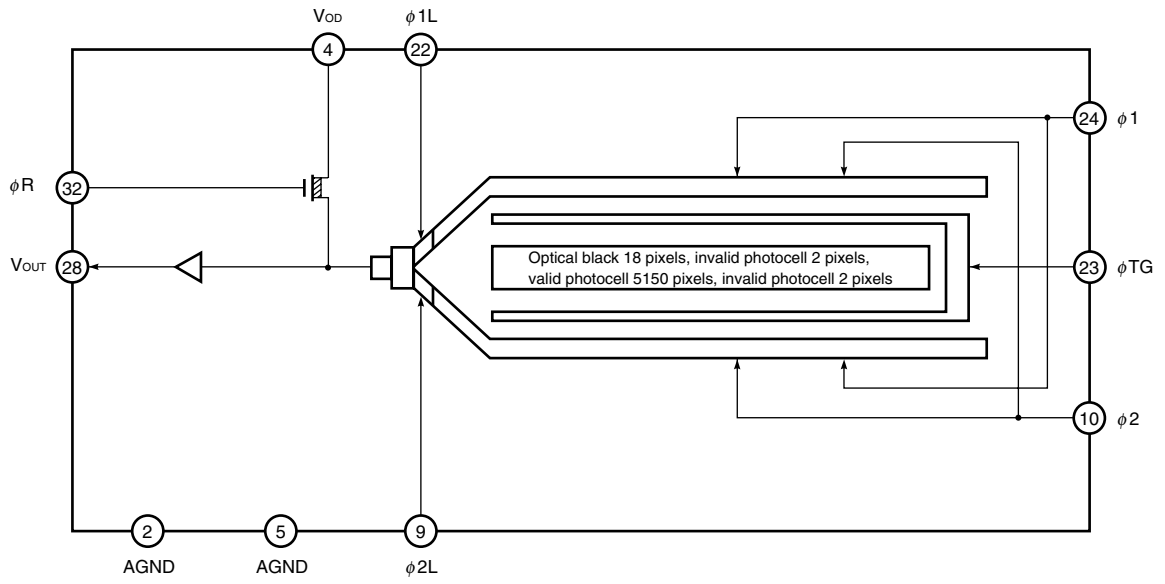

★ PIN CONFIGURATION (Top View)

CCD linear image sensor 32-pin plastic DIP (10.16 mm (400))

• μPD3737CY

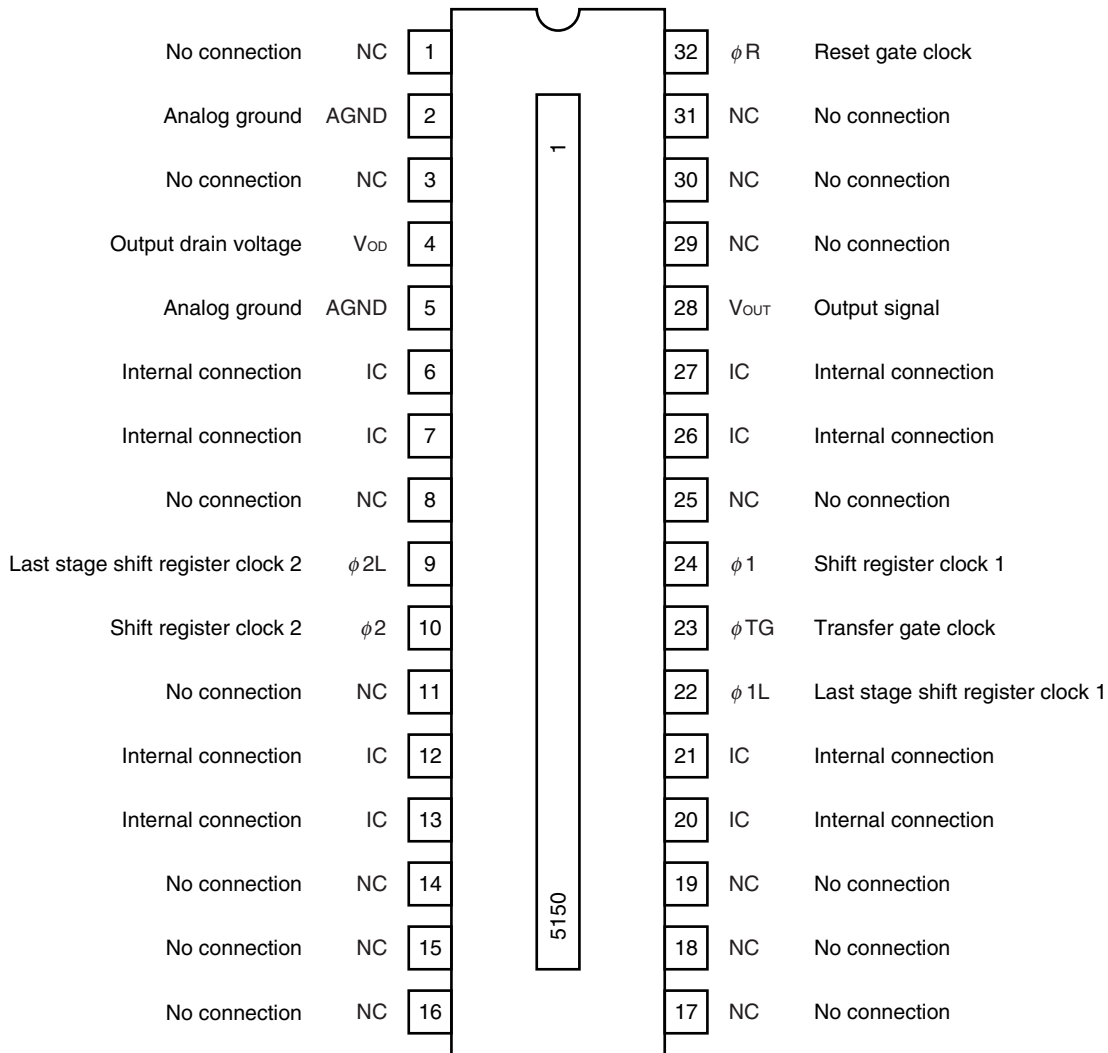

- Cautions**
1. Leave pins 6, 7, 12, 13, 20, 21, 26, 27 (IC) unconnected.
 2. Connect the No connection pins (NC) to GND.

PHOTOCELL STRUCTURE DIAGRAM

★

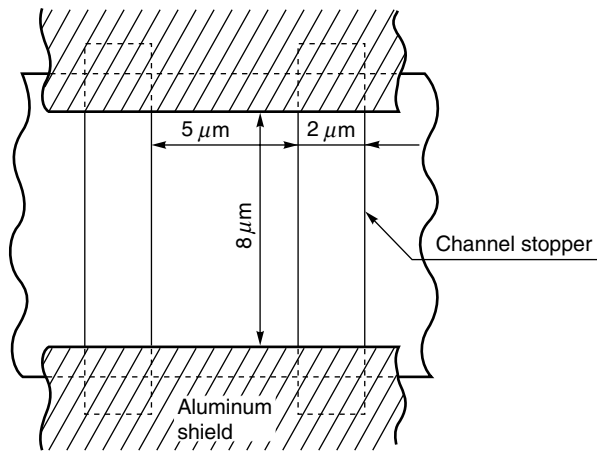

ABSOLUTE MAXIMUM RATINGS (T_A = +25°C)

Parameter	Symbol	Ratings	Unit
Output drain voltage	V _{OD}	-0.3 to +15	V
★ Shift register clock voltage	V _{φ1} , V _{φ2}	-0.3 to +8	V
★ Last stage shift register clock voltage	V _{φ1L} , V _{φ2L}	-0.3 to +8	V
★ Reset signal voltage	V _{φR}	-0.3 to +8	V
★ Transfer gate clock voltage	V _{φTG}	-0.3 to +8	V
★ Operating ambient temperature ^{Note}	T _A	0 to +60	°C
★ Storage temperature	T _{sig}	-40 to +70	°C

Note Use at the condition without dew condensation.

Caution Product quality may suffer if the absolute maximum rating is exceeded even momentarily for any parameter. That is, the absolute maximum ratings are rated values at which the product is on the verge of suffering physical damage, and therefore the product must be used under conditions that ensure that the absolute maximum ratings are not exceeded.

RECOMMENDED OPERATING CONDITIONS (T_A = +25°C)

Parameter	Symbol	Min.	Typ.	Max.	Unit
Output drain voltage	V _{OD}	11.4	12.0	12.6	V
Shift register clock high level	V _{φ1_H} , V _{φ2_H}	4.5	5.0	5.5	V
Shift register clock low level	V _{φ1_L} , V _{φ2_L}	-0.3	0	+0.5	V
★ Last stage shift register clock high level	V _{φ1LH} , V _{φ2LH}	4.5	5.0	5.5	V
★ Last stage shift register clock low level	V _{φ1LL} , V _{φ2LL}	-0.3	0	+0.5	V
Reset signal φR high level	V _{φRH}	4.5	5.0	5.5	V
Reset signal φR low level	V _{φRL}	-0.3	0	+0.5	V
Transfer gate clock high level	V _{φTGH}	4.5	V _{φ1_H} ^{Note}	V _{φ1_H} ^{Note}	V
Transfer gate clock low level	V _{φTGL}	-0.3	0	+0.5	V
★ Shift register clock amplitude	V _{φ1_pp} , V _{φ2_pp}	4.5	5.0	5.8	V
★ Last stage shift register clock amplitude	V _{φ1L_pp} , V _{φ2L_pp}	4.5	5.0	5.8	V
★ Reset signal amplitude	V _{φR_pp}	4.5	5.0	5.8	V
★ Transfer gate clock amplitude	V _{φTG_pp}	4.5	5.0	5.8	V
Data rate	f _{φR}	0.5	1	20	MHz

Note When Transfer gate clock high level (V_{φTGH}) is higher than Shift register clock high level (V_{φ1_H}), Image lag can increase.

- ★ **Remarks1.** Input reset signal φR to pin 32 via capacitor (1000 pF ±20%, non polarity). Concerning the connection method refer to **APPLICATION CIRCUIT EXAMPLE**.
- 2. Operating conditions of reset signal φR is not the condition at device pins but the conditions of the signal which applied to capacitor.

ELECTRICAL CHARACTERISTICS

$T_A = +25^{\circ}\text{C}$, $V_{OD} = 12\text{ V}$, $f_{\phi 1} = 0.5\text{ MHz}$, data rate = 1 MHz, storage time = 10 ms, input signal clock = 5 V_{p-p},
light source : 3200 K halogen lamp + C500 (infrared cut filter, t = 1 mm)

Parameter	Symbol	Test Conditions	Min.	Typ.	Max.	Unit
Saturation voltage	V _{sat}		1.0	1.5	–	V
Saturation exposure	SE	Daylight color fluorescent lamp	–	0.2	–	lx*s
Photo response non-uniformity	PRNU	V _{OUT} = 500 mV	–	±5	±10	%
★ Average dark signal	ADS	Light shielding	–	2.0	6.0	mV
★ Dark signal non-uniformity	DSNU	Light shielding	–	6.0	12.0	mV
★ Power consumption	P _w		–	100	200	mW
Output impedance	Z _o		–	0.2	0.5	kΩ
Response	R _F	Daylight color fluorescent lamp	6.0	7.5	9.0	V/lx*s
Response peak			–	550	–	nm
Image lag	IL	V _{OUT} = 1.0 V	–	0.3	1.0	%
Offset level ^{Note 1}	V _{OS}		2.0	3.0	5.0	V
★ Output fall delay time ^{Note 2}	t _d	Time from 90% to 10% of φ2L fall is 5 ns	21	23	25	ns
Register imbalance	RI	V _{OUT} = 500 mV	–	0	4.0	%
Total transfer efficiency	TTE	V _{OUT} = 500 mV, data rate (f _{φR1}) = 20 MHz	92	98	–	%
★ Dynamic range	DR1	V _{sat} /DSNU	–	250	–	times
Reset feed-through noise ^{Note 1}	RFTN	Light shielding	–	250	500	mV

Notes 1. Refer to **TIMING CHART 2.**

2. t_d is defined as a time from 10% of φ2L to 10% of V_{OUT}, output after passing through two steps of emitter follower in the **APPLICATION CIRCUIT EXAMPLE.**

★ **INPUT PIN CAPACITANCE (T_A = +25°C, V_{OD} = 12 V)**

Parameter	Symbol	Pin name	Pin No.	Min.	Typ.	Max.	Unit
Shift register clock pin capacitance 1	C _{φ1}	φ1	24	440	550	660	pF
Shift register clock pin capacitance 2	C _{φ2}	φ2	10	440	550	660	pF
Last stage shift register clock pin capacitance 1	C _{φ1L}	φ1L	22	40	50	60	pF
Last stage shift register clock pin capacitance 2	C _{φ2L}	φ2L	9	40	50	60	pF
Reset gate clock pin capacitance	C _{φR}	φR	32	8	10	12	pF
Transfer gate clock pin capacitance	C _{φTG}	φTG	23	120	150	180	pF

Remark C_{φ1} and C_{φ2} show the equivalent capacity of the real drive including the capacity of between φ1 and φ2.

★ TIMING CHART 1

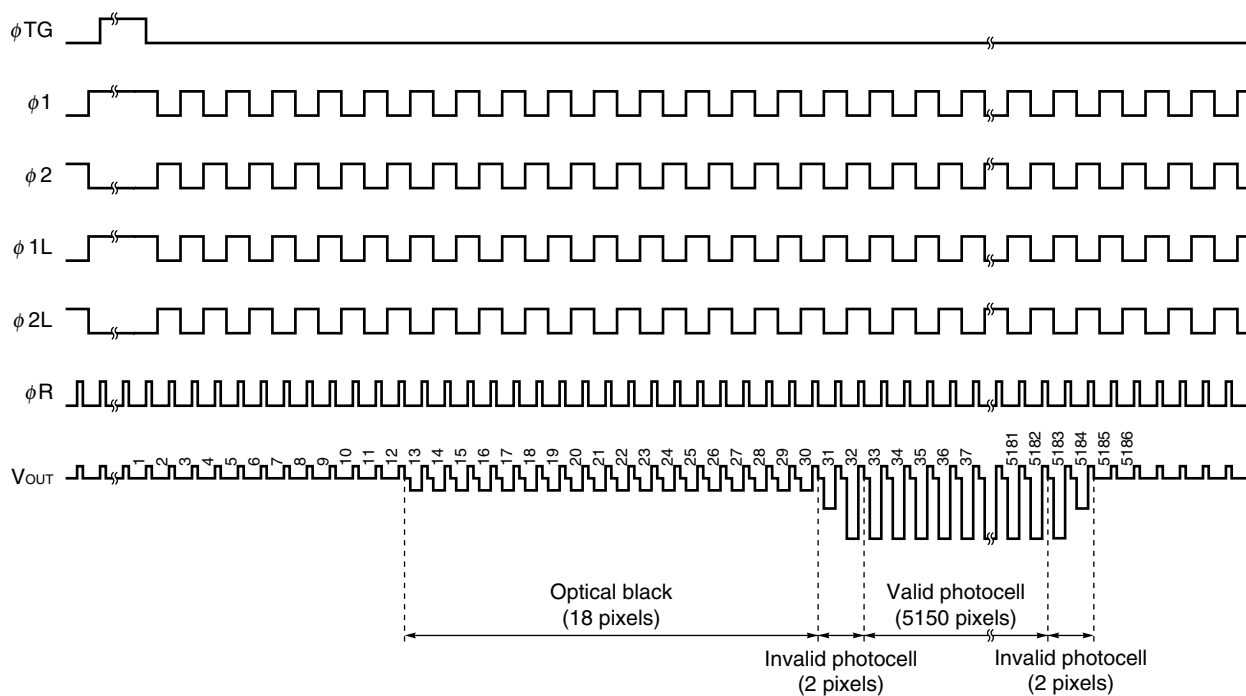

Caution Input the ϕ R pulse continuously during the high level period of ϕ TG.

TIMING CHART 2

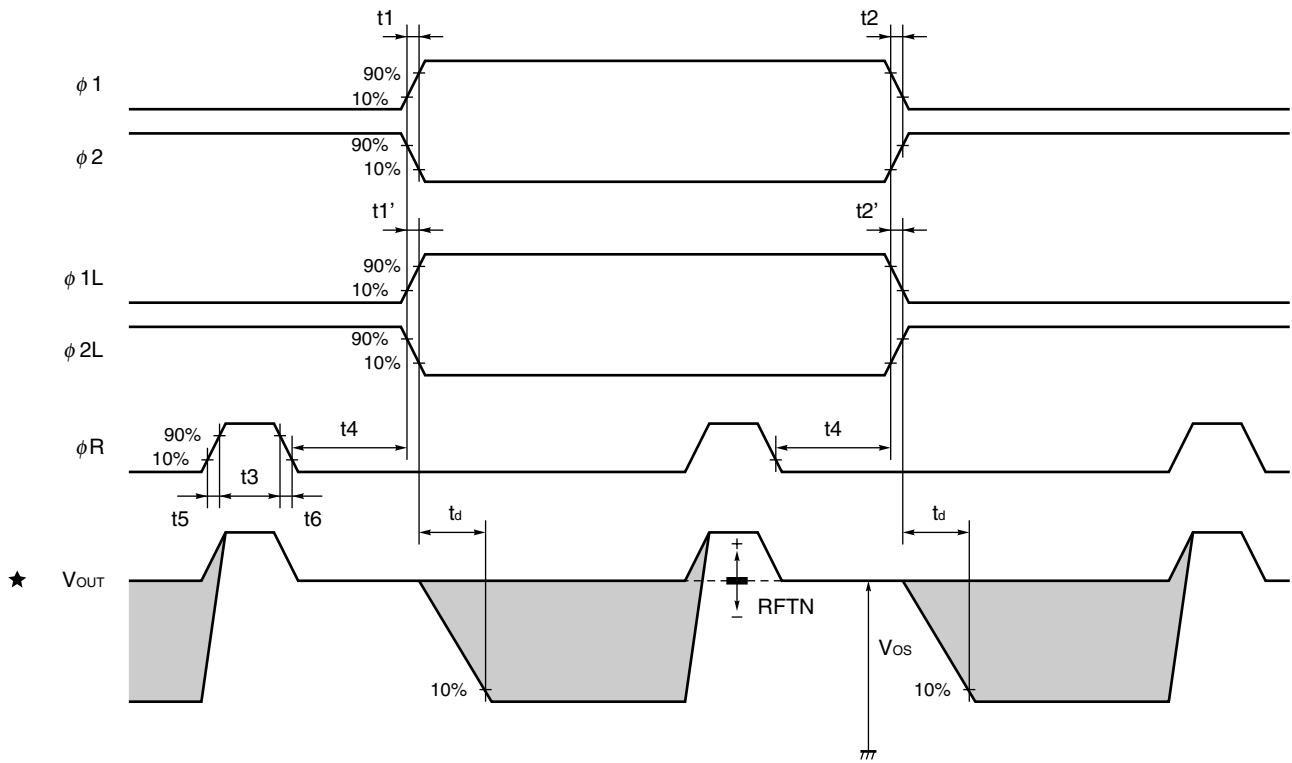

Symbol	Min.	Typ.	Max.	Unit
t_1, t_2	0	50	(150)	ns
t_1', t_2'	0	5	(25)	ns
t_3	15	50	(500)	ns
t_4	2	20	(500)	ns
t_5, t_6	0	20	(50)	ns

Remark The MAX. in the table above shows the operation range in which the output characteristics are kept almost enough for general purpose.

φTG, φ1, φ2 TIMING CHART

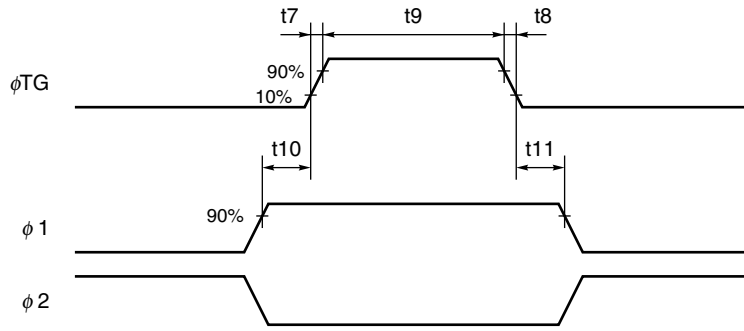

Symbol	Min.	Typ.	Max.	Unit
t7, t8	0	50	(100)	ns
t9	500	1000	10000	ns
t10, t11	0	100	10000	ns

★
★

Remark The MAX. in the table above shows the operation range in which the output characteristics are kept almost enough for general purpose.

φ1, φ2 CROSS POINTS

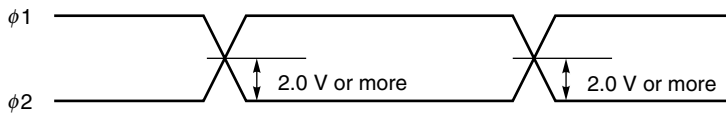

φ1L, φ2 CROSS POINTS

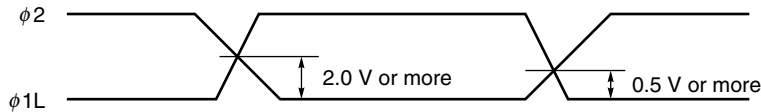

φ1, φ2L CROSS POINTS

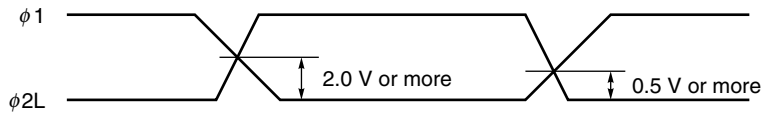

Remark Adjust cross points (φ1, φ2), (φ1L, φ2) and (φ1, φ2L) with input resistance of each pin.

DEFINITIONS OF CHARACTERISTIC ITEMS

1. Saturation voltage : **V_{sat}**
Output signal voltage at which the response linearity is lost.
2. Saturation exposure : **SE**
Product of intensity of illumination (lx) and storage time (s) when saturation of output voltage occurs.
3. Photo response non-uniformity : **PRNU**
The peak/bottom ratio to the average output voltage of all the valid pixels calculated by the following formula.

$$PRNU (\%) = \left(\frac{V_{MAX. \text{ OF } V_{MIN.}}}{\frac{1}{n} \sum_{j=1}^n V_j} - 1 \right) \times 100$$

n : Number of valid pixcels

V_j : Output voltage of each pixel

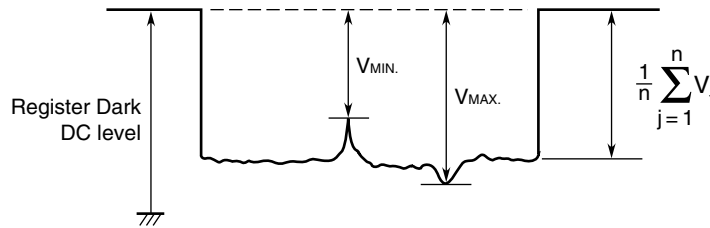

4. Average dark signal : **ADS**
Average output signal voltage of all the valid pixels at light shielding. This is calculated by the following formula.

$$ADS (mV) = \frac{\sum_{j=1}^{5150} d_j}{5150}$$

d_j : Dark signal of valid pixel number j

5. Dark signal non-uniformity : **DSNU**
The difference between ADS and voltage of the highest or lowest output pixel of all the valid pixels at light shielding.

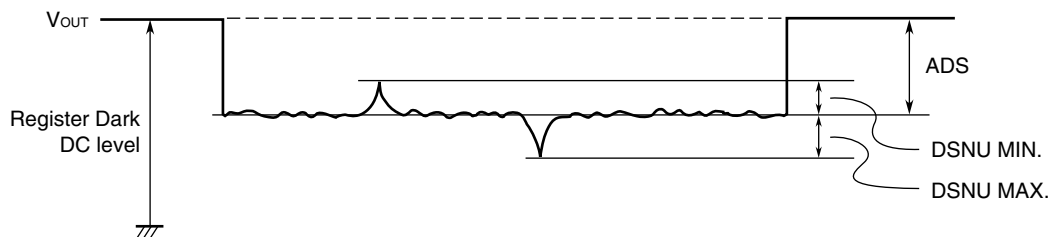

6. Output impedance : **Z_o**
 Impedance of the output pins viewed from outside.

7. Response : **R**
 Output voltage divided by exposure (lx•s).
 Note that the response varies with a light source (spectral characteristic).

8. Image lag : **IL**
 The rate between the last output voltage and the next one after read out the data of a line.

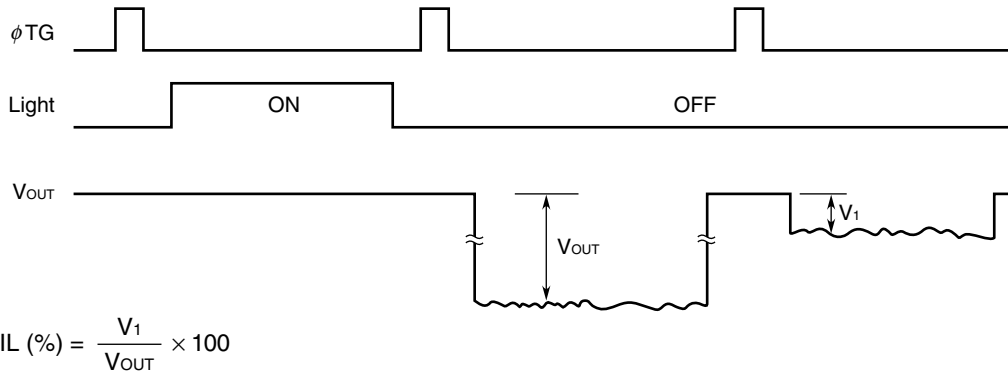

9. Register imbalance: **RI**
 The rate of the difference between the averages of the output voltage of Odd and Even pixels, against the average output voltage of all the valid pixels.

$$RI (\%) = \frac{\frac{2}{n} \left| \sum_{j=1}^{\frac{n}{2}} (V_{2j-1} - V_{2j}) \right|}{\frac{1}{n} \sum_{j=1}^n V_j} \times 100$$

n : Number of valid pixels
 V_j : Output voltage of each pixel

STANDARD CHARACTERISTIC CURVES (Reference Value)

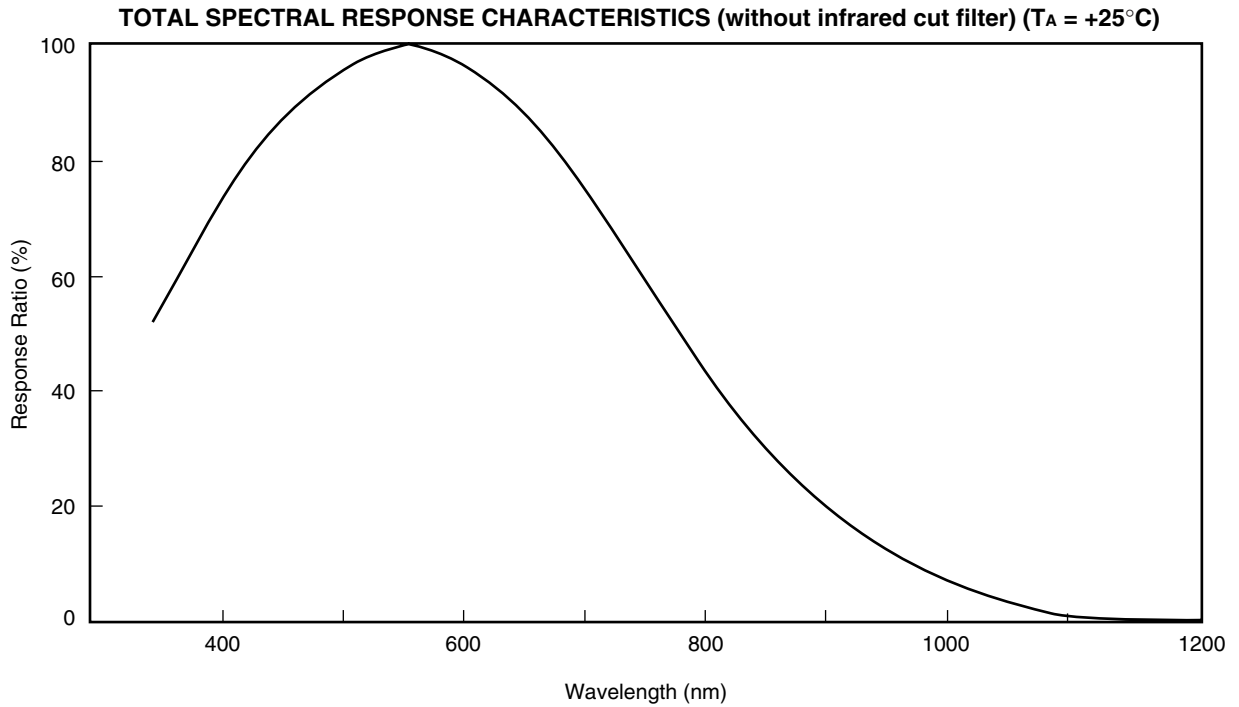
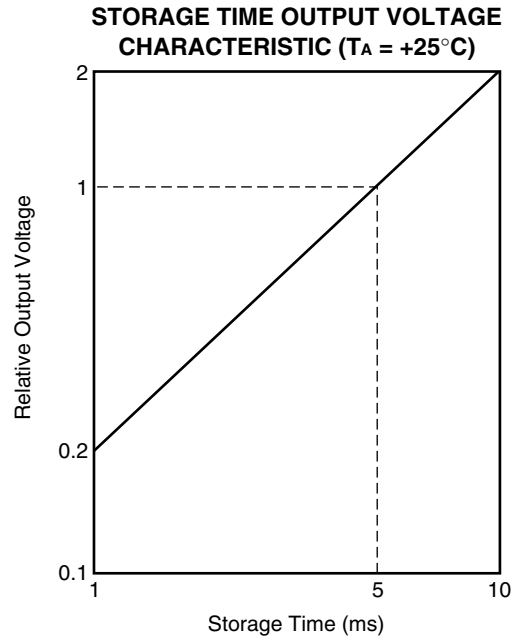
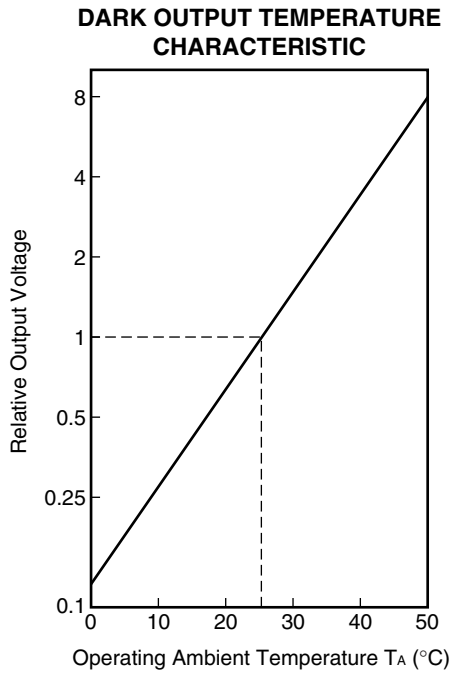

★ APPLICATION CIRCUIT EXAMPLE

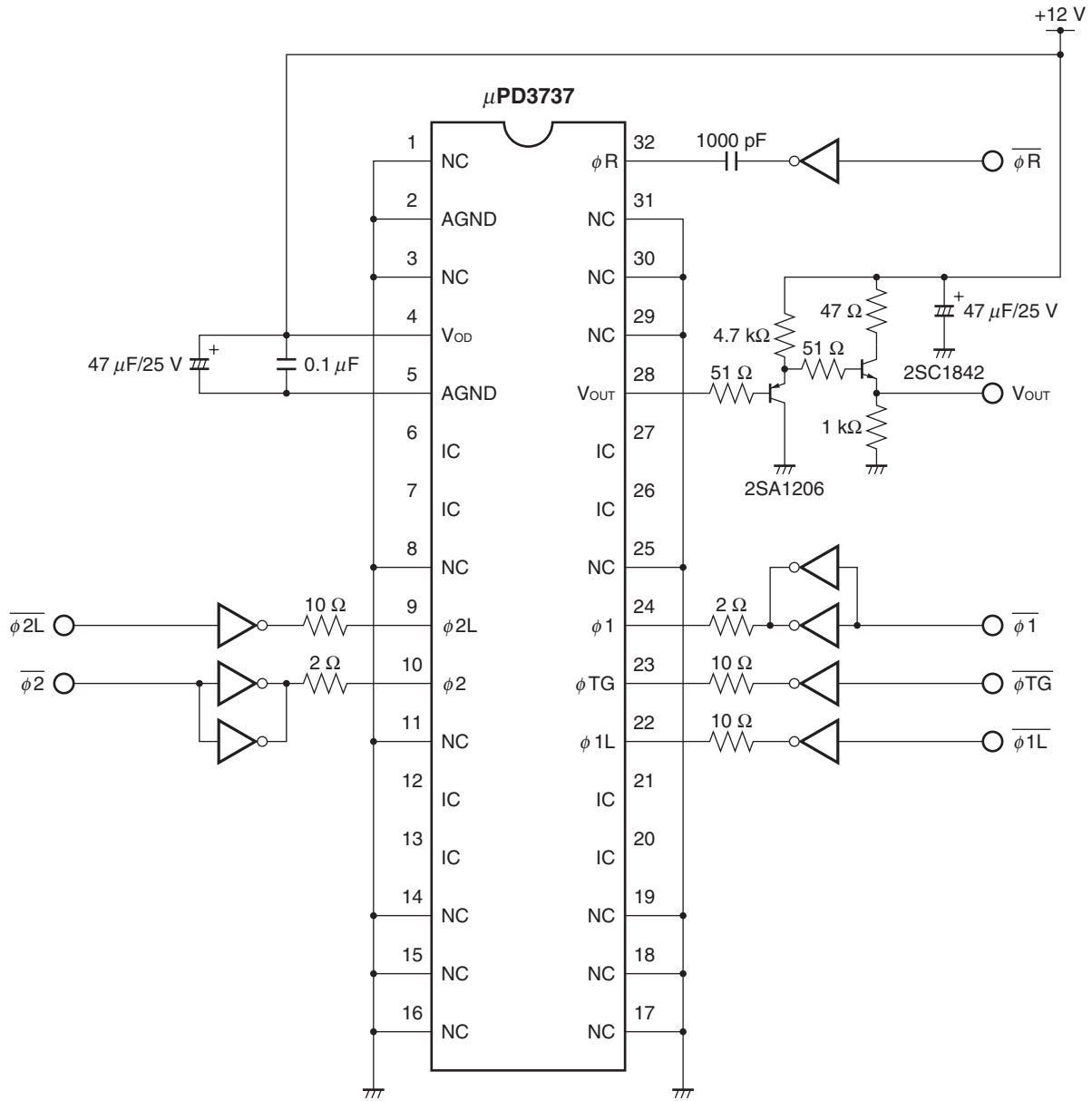

- Cautions**
1. Leave pins 6, 7, 12, 13, 20, 21, 26, 27 (IC) unconnected.
 2. Connect the No connection pins (NC) to GND.

Remark The inverters shown in the above application circuit example are the 74AC04.

★ PACKAGE DRAWING

μPD3737CY
 CCD LINEAR IMAGE SENSOR 32-PIN PLASTIC DIP (10.16 mm (400))

(Unit : mm)

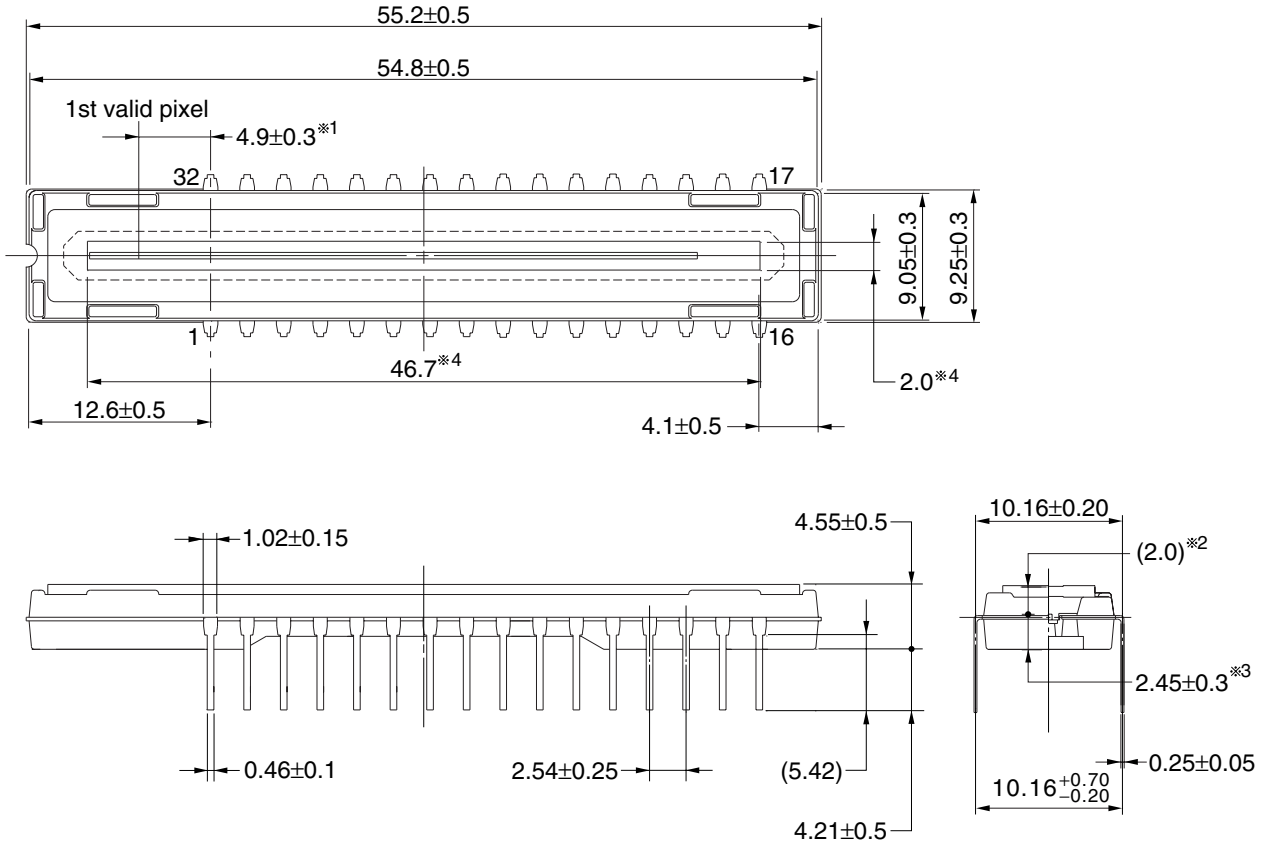

Name	Dimensions	Refractive index
Plastic cap	52.2×6.4×0.8 (0.7 ^{*5})	1.5

- ※1 1st valid pixel ←→ The center of the pin1
- ※2 The surface of the CCD chip ←→ The top of the cap
- ※3 The bottom of the package ←→ The surface of the CCD chip
- ※4 Mirror finished surface
- ※5 Thickness of mirror finished surface

32C-1CCD-PKG9-1

★ **RECOMMENDED SOLDERING CONDITIONS**

When soldering this product, it is highly recommended to observe the conditions as shown below.

If other soldering processes are used, or if the soldering is performed under different conditions, please make sure to consult with our sales offices.

Type of Through-hole Device

μPD3737CY : CCD linear image sensor 32-pin plastic DIP (10.16 mm (400))

Process	Conditions
Partial heating method	Pin temperature : 350 °C or below, Heat time : 3 seconds or less (per pin)

- Cautions**
1. **During assembly care should be taken to prevent solder or flux from contacting the glass cap. The optical characteristics could be degraded by such contact.**
 2. **Soldering by the solder flow method may have deleterious effects on prevention of glass cap soiling and heat resistance. So the method cannot be guaranteed.**



NOTES ON HANDLING THE PACKAGES

① DUST AND DIRT PROTECTING

The optical characteristics of the CCD will be degraded if the cap is scratched during cleaning. Don't either touch plastic cap surface by hand or have any object come in contact with plastic cap surface. Should dirt stick to a plastic cap surface, blow it off with an air blower. For dirt stuck through electricity ionized air is recommended. And if the plastic cap surface is grease stained, clean with our recommended solvents.

○ CLEANING THE PLASTIC CAP

Care should be taken when cleaning the surface to prevent scratches.

We recommend cleaning the cap with a soft cloth moistened with one of the recommended solvents below. Excessive pressure should not be applied to the cap during cleaning. If the cap requires multiple cleanings it is recommended that a clean surface or cloth be used.

○ RECOMMENDED SOLVENTS

The following are the recommended solvents for cleaning the CCD plastic cap.

Use of solvents other than these could result in optical or physical degradation in the plastic cap. Please consult your sales office when considering an alternative solvent.

Solvents	Symbol
Ethyl Alcohol	EtOH
Methyl Alcohol	MeOH
Isopropyl Alcohol	IPA
N-methyl Pyrrolidone	NMP

② MOUNTING OF THE PACKAGE

The application of an excessive load to the package may cause the package to warp or break, or cause chips to come off internally. Particular care should be taken when mounting the package on the circuit board. Don't have any object come in contact with plastic cap. You should not reform the lead frame. We recommended to use a IC-inserter when you assemble to PCB.

Also, be care that the any of the following can cause the package to crack or dust to be generated.

1. Applying heat to the external leads for an extended period of time with soldering iron.
2. Applying repetitive bending stress to the external leads.
3. Rapid cooling or heating

③ OPERATE AND STORAGE ENVIRONMENTS

Operate in clean environments. CCD image sensors are precise optical equipment that should not be subject to mechanical shocks. Exposure to high temperatures or humidity will affect the characteristics. So avoid storage or usage in such conditions.

Keep in a case to protect from dust and dirt. Dew condensation may occur on CCD image sensors when the devices are transported from a low-temperature environment to a high-temperature environment. Avoid such rapid temperature changes.

For more details, refer to our document "Review of Quality and Reliability Handbook" (C12769E)

④ ELECTROSTATIC BREAKDOWN

CCD image sensor is protected against static electricity, but destruction due to static electricity is sometimes detected. Before handling be sure to take the following protective measures.

1. Ground the tools such as soldering iron, radio cutting pliers or of pincer.
2. Install a conductive mat or on the floor or working table to prevent the generation of static electricity.
3. Either handle bare handed or use non-chargeable gloves, clothes or material.
4. Ionized air is recommended for discharge when handling CCD image sensor.
5. For the shipment of mounted substrates, use box treated for prevention of static charges.
6. Anyone who is handling CCD image sensors, mounting them on PCBs or testing or inspecting PCBs on which CCD image sensors have been mounted must wear anti-static bands such as wrist straps and ankle straps which are grounded via a series resistance connection of about 1 MΩ.

[MEMO]

[MEMO]

NOTES FOR CMOS DEVICES**① PRECAUTION AGAINST ESD FOR SEMICONDUCTORS**

Note:

Strong electric field, when exposed to a MOS device, can cause destruction of the gate oxide and ultimately degrade the device operation. Steps must be taken to stop generation of static electricity as much as possible, and quickly dissipate it once, when it has occurred. Environmental control must be adequate. When it is dry, humidifier should be used. It is recommended to avoid using insulators that easily build static electricity. Semiconductor devices must be stored and transported in an anti-static container, static shielding bag or conductive material. All test and measurement tools including work bench and floor should be grounded. The operator should be grounded using wrist strap. Semiconductor devices must not be touched with bare hands. Similar precautions need to be taken for PW boards with semiconductor devices on it.

② HANDLING OF UNUSED INPUT PINS FOR CMOS

Note:

No connection for CMOS device inputs can be cause of malfunction. If no connection is provided to the input pins, it is possible that an internal input level may be generated due to noise, etc., hence causing malfunction. CMOS devices behave differently than Bipolar or NMOS devices. Input levels of CMOS devices must be fixed high or low by using a pull-up or pull-down circuitry. Each unused pin should be connected to V_{DD} or GND with a resistor, if it is considered to have a possibility of being an output pin. All handling related to the unused pins must be judged device by device and related specifications governing the devices.

③ STATUS BEFORE INITIALIZATION OF MOS DEVICES

Note:

Power-on does not necessarily define initial status of MOS device. Production process of MOS does not define the initial operation status of the device. Immediately after the power source is turned ON, the devices with reset function have not yet been initialized. Hence, power-on does not guarantee out-pin levels, I/O settings or contents of registers. Device is not initialized until the reset signal is received. Reset operation must be executed immediately after power-on for devices having reset function.

• **The information in this document is current as of September, 2003. The information is subject to change without notice. For actual design-in, refer to the latest publications of NEC Electronics data sheets or data books, etc., for the most up-to-date specifications of NEC Electronics products. Not all products and/or types are available in every country. Please check with an NEC Electronics sales representative for availability and additional information.**

• No part of this document may be copied or reproduced in any form or by any means without the prior written consent of NEC Electronics. NEC Electronics assumes no responsibility for any errors that may appear in this document.

• NEC Electronics does not assume any liability for infringement of patents, copyrights or other intellectual property rights of third parties by or arising from the use of NEC Electronics products listed in this document or any other liability arising from the use of such products. No license, express, implied or otherwise, is granted under any patents, copyrights or other intellectual property rights of NEC Electronics or others.

• Descriptions of circuits, software and other related information in this document are provided for illustrative purposes in semiconductor product operation and application examples. The incorporation of these circuits, software and information in the design of a customer's equipment shall be done under the full responsibility of the customer. NEC Electronics assumes no responsibility for any losses incurred by customers or third parties arising from the use of these circuits, software and information.

• While NEC Electronics endeavors to enhance the quality, reliability and safety of NEC Electronics products, customers agree and acknowledge that the possibility of defects thereof cannot be eliminated entirely. To minimize risks of damage to property or injury (including death) to persons arising from defects in NEC Electronics products, customers must incorporate sufficient safety measures in their design, such as redundancy, fire-containment and anti-failure features.

• NEC Electronics products are classified into the following three quality grades: "Standard", "Special" and "Specific".

The "Specific" quality grade applies only to NEC Electronics products developed based on a customer-designated "quality assurance program" for a specific application. The recommended applications of an NEC Electronics product depend on its quality grade, as indicated below. Customers must check the quality grade of each NEC Electronics product before using it in a particular application.

"Standard": Computers, office equipment, communications equipment, test and measurement equipment, audio and visual equipment, home electronic appliances, machine tools, personal electronic equipment and industrial robots.

"Special": Transportation equipment (automobiles, trains, ships, etc.), traffic control systems, anti-disaster systems, anti-crime systems, safety equipment and medical equipment (not specifically designed for life support).

"Specific": Aircraft, aerospace equipment, submersible repeaters, nuclear reactor control systems, life support systems and medical equipment for life support, etc.

The quality grade of NEC Electronics products is "Standard" unless otherwise expressly specified in NEC Electronics data sheets or data books, etc. If customers wish to use NEC Electronics products in applications not intended by NEC Electronics, they must contact an NEC Electronics sales representative in advance to determine NEC Electronics' willingness to support a given application.

(Note)

(1) "NEC Electronics" as used in this statement means NEC Electronics Corporation and also includes its majority-owned subsidiaries.

(2) "NEC Electronics products" means any product developed or manufactured by or for NEC Electronics (as defined above).