

507-013 Split Backshell for Cannon DPKA, DPKB, and DPJM Series Connectors



ARINC Series
400 (Cannon)

507-013 A M

Basic Part No. _____

Connector Symbol (Table I) _____

Finish: _____

- B = Cadmium Plate/Olive Drab
- J = Iridite, Gold Over Cadmium Plate Over Nickel
- M = Electroless Nickel
- N = Cadmium Plate/Olive Drab over Nickel Plate
- T = Cadmium Plate, Bright Dip, Over Nickel (500 Hour Salt Spray)
- Omit for Cadmium Olive Drab Over Electroless Nickel (1000 Hour Salt Spray)

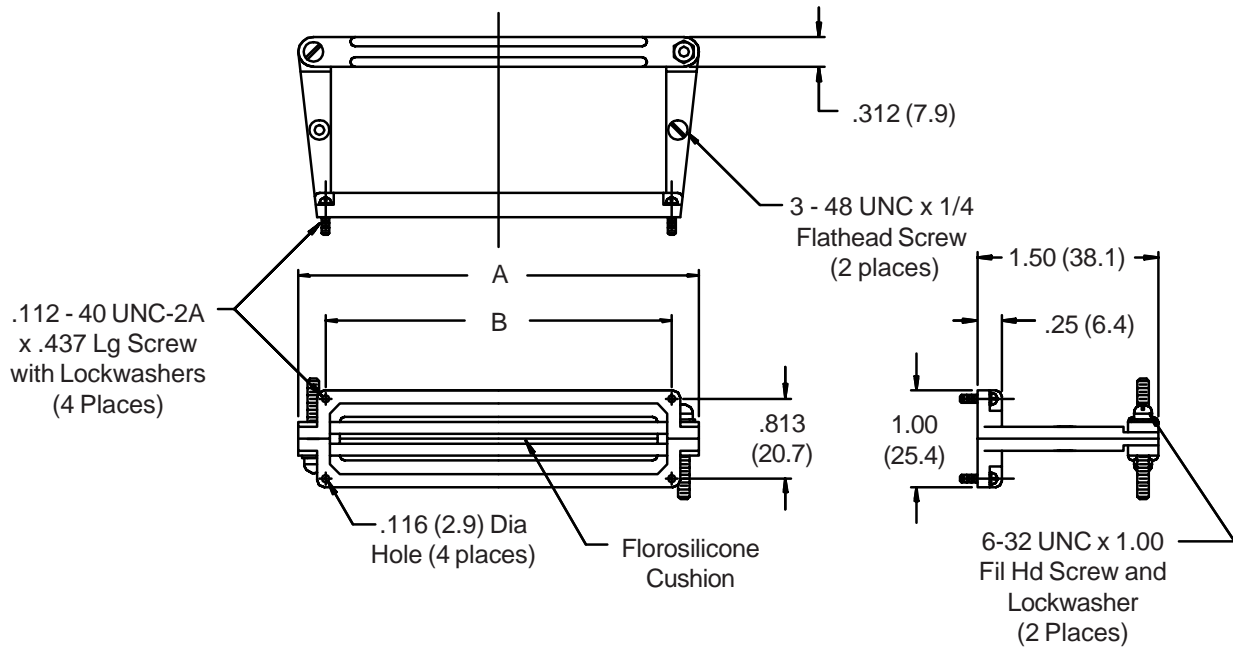

TABLE I: CONNECTOR INTERFACE DIMS					
Connector Symbol	Connector Series	A		B	
		± 0.062	(1.6)	± 0.005	(.1)
A	DPKA	2.437	(61.9)	1.895	(48.1)
B	DPKB/DPJM	3.750	(95.3)	3.195	(81.2)

1. Metric dimensions (mm) are indicated in parentheses.
2. Material/Finish:
 - Frame and Saddles = Al Alloy/Finish Per Part Number Development.
 - Hardware = SST/Passivate
 - Saddle Cushion = Fluorosilicone/N.A.