



LC866020/16/12/08C

8-Bit Single Chip Microcontroller with On-Chip 20/16/12/08K-Byte ROM and 384-Byte RAM

Preliminary

Overview

The LC866020C/16C/12C/08C microcontrollers are 8-bit single chip microcontrollers with the following on-chip functional blocks :

- CPU : Operable at a minimum bus cycle time of 0.5 μ s (microsecond)
- On-chip ROM maximum capacity : 20K bytes
- On-chip RAM capacity : 384 bytes
- VFD automatic display controller/driver
- 16-bit timer/counter (or two 8-bit timers)
- 16-bit timer/PWM (or two 8-bit timers)
- 4 channels 8-bit AD converter
- Two 8-bit synchronous serial interface circuits
- 14-source 10-level vectored interrupt system

All of the above functions are fabricated on a single chip.

Features

- | | | |
|------------------------------|-----------|-----------------------|
| (1) Read-Only Memory (ROM) : | LC866020C | 20480 \times 8 bits |
| | LC866016C | 16384 \times 8 bits |
| | LC866012C | 12288 \times 8 bits |
| | LC866008C | 8192 \times 8 bits |
- (2) Random Access Memory (RAM) : LC866020C/16C/12C/08C 384 \times 8 bits
- (3) Minimum bus cycle time : 0.5 μ s (using 12MHz CF resonator oscillation)
 Bus cycle time means ROM-read period.

- Any and all SANYO products described or contained herein do not have specifications that can handle applications that require extremely high levels of reliability, such as life-support systems, aircraft's control systems, or other applications whose failure can be reasonably expected to result in serious physical and/or material damage. Consult with your SANYO representative nearest you before using any SANYO products described or contained herein in such applications.
- SANYO assumes no responsibility for equipment failures that result from using products at values that exceed, even momentarily, rated values (such as maximum ratings, operating condition ranges, or other parameters) listed in products specifications of any and all SANYO products described or contained herein.

(4) Minimum instruction cycle time : 1 μ s (using 12MHz CF resonator oscillation)

ROM data is accessed twice in a instruction cycle time. The operation of the microcomputers herein is about 1.7 times that of LC66000 series, our products in the same specified cycle time.

(5) Ports

- Input/output ports : 2 ports (16 terminals)
- Input/output port programmable in nibble units : 1 port (8 terminals)
- Input/output port programmable in a bit : 1 port (8 terminals)
- Input ports : 2 ports (8 port pins)
- VFD output ports : 30 terminals
- Large current output for digit : 16 terminals
- Pull-down resistor option available

(6) VFD automatic display controller

- Segment/digit output pattern programmable
Any segment/digit combination available
VFD parallel-drive available
- 16-step dimmer function available

(7) AD converter

- 4-channels 8-bit AD converter

(8) Serial interface

- Two 8-bit serial-interface circuits
- LSB first/MSB first function available
- Internal 8-bit baud-rate generator in common with two serial-interface circuits

(9) Timers

- Timer0 : 16-bit timer / counter with 2-bit prescaler + 8-bit programmable prescaler

Mode 0 : Two 8-bit timers with programmable prescaler

Mode 1 : 8-bit timer with programmable prescaler + 8-bit counter

Mode 2 : 16-bit timer with programmable prescaler

Mode 3 : 16-bit counter

The resolution of Timer0 is 1 tCYC, the cycle time.

- Timer1 : 16-bit timer / PWM

Mode 0 : Two 8-bit timers

Mode 1 : 8-bit timer + 8-bit PWM

Mode 2 : 16-bit timer

Mode 3 : Variable bit PWM (9 to 16 bits)

In Mode 0 and Mode 1, the resolution of Timer1 and PWM is tCYC.

In Mode 2 and Mode 3, the resolution is selectable by program ; tCYC or 1/2tCYC

- Base timer

Every 500ms overflow system for a clock application (using 32.768kHz crystal oscillation for base timer clock)

Every 976 μ s, 3.9ms, 15.6ms, 62.5ms overflow system (using 32.768kHz crystal oscillation for base timer clock)

The base timer clock selectable, 32.768kHz crystal oscillation, system clock, and programmable prescaler output of Timer0.

(10) Buzzer output

- The buzzer sound frequency selectable ; 4kHz, 2kHz (using 32.768kHz crystal oscillation for timer clock)

(11) Remote control receiver circuit (connected to the P73/INT3/T0IN terminal)

- Noise rejection function
- Polarity switching

(12) Watchdog timer

- The watchdog timer is taken on RC outside.
- Watchdog timer operation selectable : interrupt system, system reset

(13) Interrupt system

- 14-source 10-level vectored interrupts :
 1. External interrupt INT0 (includes watchdog timer)
 2. External interrupt INT1
 3. External interrupt INT2, timer/counter T0L (Lower 8 bits)
 4. External interrupt INT3, base timer
 5. Timer/counter T0H (Upper 8 bits)
 6. Timer T1H /T1L
 7. Serial interface SIO0
 8. Serial interface SIO1
 9. AD converter
 10. VFD display controller, port 0
- Interrupt priority control available
 - The interrupt priority control register included.
 - These microcomputers allows 3-level interrupt ; low-level, high-level and highest-level of multiplex interrupt. It can specify a low-level or a high-level interrupt priority from INT2/T0L through VFD display controller/port 0 (the above interrupt number from 3 to 10).
 - It can also specify a low-level or the highest-level interrupt priority to INT0 and INT1.

(14) Real-time service operation

- The Real-Time Service (RTS) functions the data-transfer between the Special Function Registers at acknowledging the interrupt request.
- The RTS starts within 1 cycle-time and completes within 5 cycle-times after occurring the interrupt request.

(15) Sub-routine stack levels

- 128 levels (Max.) : Stack area included in RAM area.

(16) Multiplication and division

- 16 bits \times 8 bits (7 instruction cycle times)
- 16 bits \div 8 bits (7 instruction cycle times)

(17) 3 oscillation circuits

- On-chip RC oscillation circuit using for the system clock
- On-chip CF oscillation circuit using for the system clock
- On-chip X'tal oscillation circuit using for the system clock and for time-base clock

(18) Standby function

- HALT mode function
 - The HALT mode is used to reduce the power dissipation. In this operation mode, the program execution is stopped.
 - This operation mode can be released by the interrupt request signals or the system reset.
- HOLD mode function
 - The HOLD mode is used to stop all the oscillations ; the RC (internal), CF and X'tal oscillations. This mode can be released by the following conditions.
 - Reset terminal ($\overline{\text{RES}}$) set to low level.
 - P70/INT0/T0IN, P71/INT1/T0IN terminals set to assigned level (programmable).
 - Port 0 terminal/terminals set to low level (programmable).

(19) Factory shipment

- DIP64S delivery form
- QFP64E delivery form

(20) Development Tools

- Evaluation chip : LC866098
- EPROM version : LC86E6032
- One time version : LC86P6032
- Emulator : EVA86000 + ECB866000 (Evaluation chip board)
+ POD866000 (Pod : DIP64S) / POD866010 (Pod : QIP64E)

Pin Assignment

•DIP64S

P10/SO0	1	64	P07
P11/SI0/SB0	2	63	P06
P12/SCK0	3	62	P05
P13/SO1	4	61	P04
P14/SI1/SB1	5	60	P03
P15/SCK1	6	59	P02
P16/BUZ	7	58	P01
P17/PWM	8	57	P00
TEST1	9	56	S29
RES	10	55	S28
XT1	11	54	S27
XT2	12	53	S26
VSS	13	52	S25
CF1	14	51	S24
CF2	15	50	S23
VDD	16	49	S22
P80/AN0	17	48	S21
P81/AN1	18	47	S20
P82/AN2	19	46	S19
P83/AN3	20	45	S18
P70/INT0	21	44	S17
P71/INT1	22	43	S16
P72/INT2/T0IN	23	42	VP
P73/INT3/T0IN	24	41	VDDVPP
S0/T0	25	40	S15/T15
S1/T1	26	39	S14/T14
S2/T2	27	38	S13/T13
S3/T3	28	37	S12/T12
S4/T4	29	36	S11/T11
S5/T5	30	35	S10/T10
S6/T6	31	34	S9/T9
S7/T7	32	33	S8/T8

Package Dimension

(unit : mm)

3071

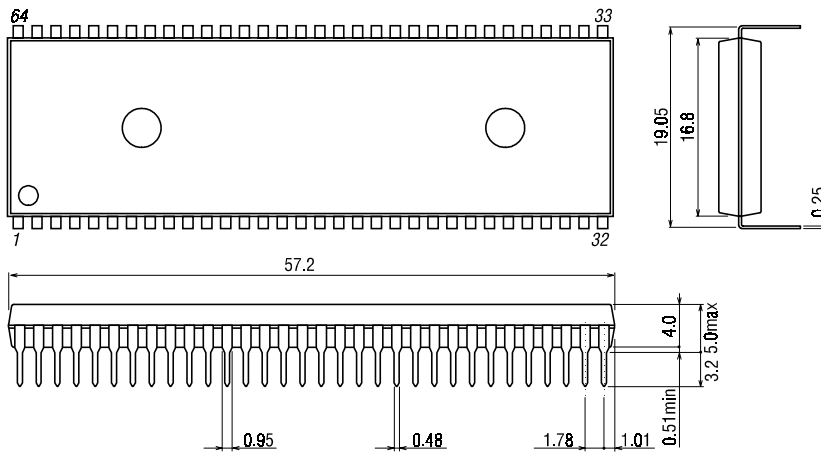

SANYO : DIP-64S(750mil)

Pin Assignment

•QIP64E

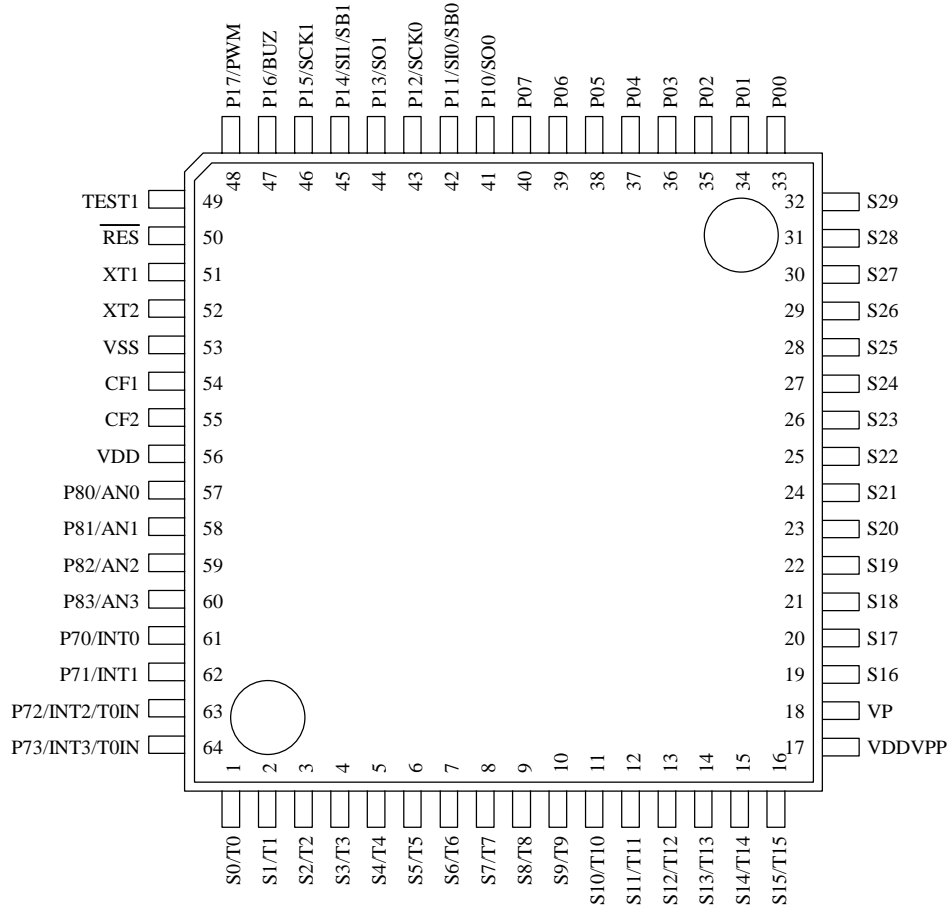

Package Dimension

(unit : mm)

3159

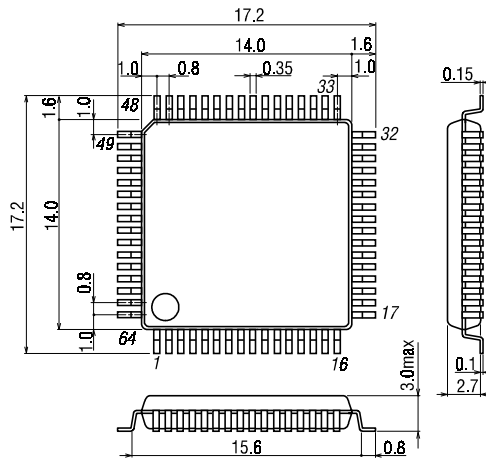

SANYO : QIP-64E

System Block Diagram

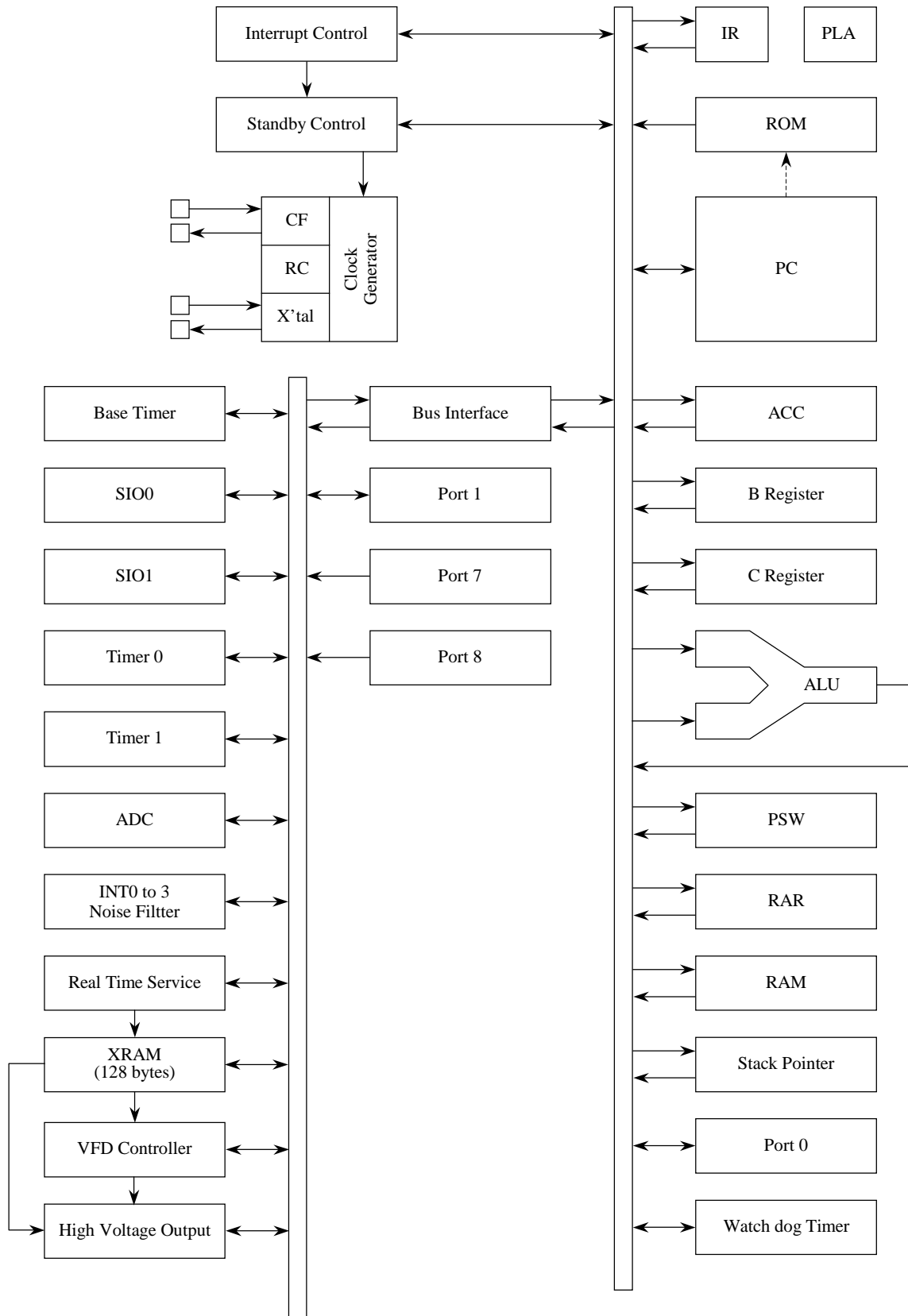

Pin Description

Pin Name	I/O	Functions	Option																																			
VSS		Power pin (-)																																				
VDD		Power pin (+)																																				
VP		Power pin (-) for VFD output pulldown resistor																																				
VDDVPP		Power pin (+) *1																																				
PORT0 P00 to P07	I/O	<ul style="list-style-type: none"> •8-bit input/output port •Input for port 0 interrupt •Input/output in nibble units •Input for HOLD release 	<ul style="list-style-type: none"> •Pullup resistor: Provided/Not provided •Output form: CMOS/N-channel open drain 																																			
PORT1 P10 to P17	I/O	<ul style="list-style-type: none"> •8-bit input/output port •Input/output can be specified in bit unit. •Other pin functions <ul style="list-style-type: none"> P10: SIO0 data output P11: SIO0 data input/bus input/output P12: SIO0 clock input/output P13: SIO1 data output P14: SIO1 data input/bus input/output P15: SIO1 clock input/output P16: Buzzer output P17: Timer 1 output (PWM output) 	<ul style="list-style-type: none"> •Output form: CMOS/N-channel open drain 																																			
PORT7 P70 P71 - P73	I/O I	<ul style="list-style-type: none"> •4-bit input port •Other functions <ul style="list-style-type: none"> P70: INT0 input / HOLD release / Nch-Tr. output for watchdog timer P71: INT1 input / HOLD release P72: INT2 input / timer 0 event input P73: INT3 input with noise filter / timer 0 event input •Interrupt received form, vector address. <table border="1"> <thead> <tr> <th></th> <th>rising</th> <th>falling</th> <th>rising/ falling</th> <th>H level</th> <th>L level</th> <th>Vector</th> </tr> </thead> <tbody> <tr> <td>INT0</td> <td>enable</td> <td>enable</td> <td>disable</td> <td>enable</td> <td>enable</td> <td>03H</td> </tr> <tr> <td>INT1</td> <td>enable</td> <td>enable</td> <td>disable</td> <td>enable</td> <td>enable</td> <td>0BH</td> </tr> <tr> <td>INT2</td> <td>enable</td> <td>enable</td> <td>enable</td> <td>disable</td> <td>disable</td> <td>13H</td> </tr> <tr> <td>INT3</td> <td>enable</td> <td>enable</td> <td>enable</td> <td>disable</td> <td>disable</td> <td>1BH</td> </tr> </tbody> </table>		rising	falling	rising/ falling	H level	L level	Vector	INT0	enable	enable	disable	enable	enable	03H	INT1	enable	enable	disable	enable	enable	0BH	INT2	enable	enable	enable	disable	disable	13H	INT3	enable	enable	enable	disable	disable	1BH	<ul style="list-style-type: none"> Pullup resistor: Provided/Not provided
	rising	falling	rising/ falling	H level	L level	Vector																																
INT0	enable	enable	disable	enable	enable	03H																																
INT1	enable	enable	disable	enable	enable	0BH																																
INT2	enable	enable	enable	disable	disable	13H																																
INT3	enable	enable	enable	disable	disable	1BH																																
PORT8 P80 to P83	I	<ul style="list-style-type: none"> •4-bit input port •Other functions <ul style="list-style-type: none"> AD input port (4 port pins) 																																				
S0/T0 to S6/T6	O	Output for VFD display controller segment/timing in common (Usable for static output port at pulldown resistor Not provided.)	<ul style="list-style-type: none"> Pullup resistor: Provided/Not provided 																																			
S7/T7 to S15/T15	O	Output for VFD display controller segment/timing with internal pulldown resistor in common.																																				
S16 to S29	O	Output for VFD display controller segment (Usable for static output port at pulldown resistor Not provided.)	<ul style="list-style-type: none"> Pullup resistor: Provided/Not provided 																																			
$\overline{\text{RES}}$	I	Reset pin																																				
TEST1	O	Test pin Should be left unconnected. Fixed high level output.																																				
XT1	I	Input pin for 32.768kHz crystal oscillation. In case of non use, connect to VDD.																																				
XT2	O	Output pin for 32.768kHz crystal oscillation. In case of non use, should be left unconnected.																																				
CF1	I	Input pin for ceramic resonator oscillation																																				
CF2	O	Output pin for ceramic resonator oscillation																																				

* All of port options can be specified in bit unit.

* A state of pins at reset.

Pin name	Input/output mode	A state of pullup resistor specified at pullup option
Ports 0,7	Input	Fixed pullup resistor exist
Port 1	Input	Programmable pullup resistor OFF

Pin name	A state of P-channel transistor
S0/T0 to S15/T15	P-channel transistor OFF
S16 to S29	P-channel transistor OFF

*1 Connect like the following figure to reduce noise into a VDD terminal
Shorten the VDD terminal to the VDDVPP terminal.

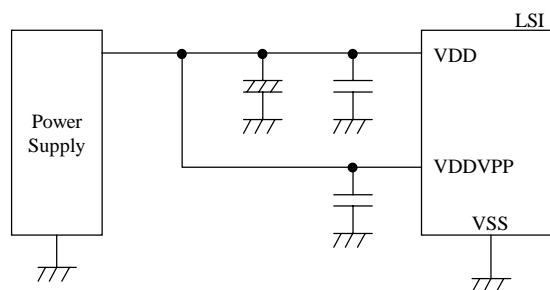

1. Absolute Maximum Ratings at VSS=0V and Ta=25°C

Parameter	Symbol	Pins	Conditions	Ratings			unit	
				VDD[V]	min.	typ.		max.
Supply voltage	VDDMAX	VDD, VDDVPP	VDD=VDDVPP		-0.3		+7.0	V
Input voltage	VI(1)	•Ports 71,72,73 •Port 8 •RES			-0.3		VDD+0.3	
	VI(2)	VP			VDD-45		VDD+0.3	
Output voltage	VO	•S0/T0 to S15/T15 •S16 to S29			VDD-45		VDD+0.3	
Input/output voltage	VIO	Ports 0,1,70			-0.3		VDD+0.3	
High level output current	Peak output current	IOPH(1)	Ports 0,1	•CMOS output •For each pin.		-4		mA
		IOPH(2)	S0/T0 to S15/T15	For each pin.		-30		
		IOPH(3)	S16 to S29	For each pin.		-15		
	Total output current	∑IOAH(1)	Port 0	Total all pins.		-10		
		∑IOAH(2)	Port 1	Total all pins.		-10		
		∑IOAH(3)	•S0/T0 to S15/T15 •S16 to S29	Total all pins.		-130		
Low level output current	Peak output current	IOPL(1)	Ports 0,1	At each pin.			20	
		IOPL(2)	Port 70	At each pin.			15	
	Total output current	∑IOAL(1)	Port 0	Total all pins.				40
		∑IOAL(2)	Ports 1,70	Total all pins.				40
Maximum power dissipation	Pdmax(1)	DIP64S	Ta=-30 to +70°C				670	mW
	Pdmax(2)	QFP64E	Ta=-30 to +70°C				380	
Operating temperature range	Topg				-30		+70	°C
Storage temperature range	Tstg				-65		+150	

2. Recommended Operating Range at Ta=-30°C to +70°C, VSS=0V

Parameter	Symbol	Pins	Conditions	Ratings			unit	
				VDD[V]	min.	typ.		max.
Operating supply voltage range	VDD(1)	VDD	0.98μs ≤ tCYC ≤ 400μs		4.5		6.0	V
	VDD(2)		3.9μs ≤ tCYC ≤ 400μs		2.5		6.0	
Hold voltage	VHD	VDD	RAM and registers contain data at HOLD mode		2.0		6.0	
Pulldown voltage	VP	VP		2.5 - 6.0	-35		VDD	
Input high voltage	VIH(1)	Port 0 (Schmitt)	Output disable	2.5 - 6.0	0.4VDD +0.9		VDD	
	VIH(2)	•Port 1 •Ports 72, 73 (Schmitt)	Output disable	2.5 - 6.0	0.75VDD		VDD	
	VIH(3)	•Port 70 port input/interrupt •Port 71 •RES (Schmitt)	Output N-channel Tr. OFF	2.5 - 6.0	0.75VDD		VDD	
	VIH(4)	Port 70 Watchdog timer input	Output N-channel Tr. OFF	2.5 - 6.0	0.9VDD		VDD	
	VIH(5)	Port 8		2.5 - 6.0	0.75VDD		VDD	
Input low voltage	VIL(1)	Port 0 (Schmitt)	Output disable	2.5 - 6.0	VSS		0.2VDD	
	VIL(2)	•Port 1 •Ports 72, 73 (Schmitt)	Output disable	2.5 - 6.0	VSS		0.25VDD	
	VIL(3)	•Port 70 port input/interrupt •Port 71 •RES (Schmitt)	N-channel Tr. OFF	2.5 - 6.0	VSS		0.25VDD	
	VIL(4)	Port 70 Watchdog timer	N-channel Tr. OFF	2.5 - 6.0	VSS		0.8VDD -1.0	
	VIL(5)	Port 8		2.5 - 6.0	VSS		0.25VDD	
Operation cycle time	tCYC			4.5 - 6.0	0.98		400	μs
				2.5 - 6.0	3.9		400	
Oscillation frequency range (Note 1)	FmCF(1)	CF1,CF2	•12MHz (ceramic resonator oscillation) •Refer to figure 1	4.5 - 6.0	11.76	12	12.24	MHz
	FmCF(2)	CF1,CF2	•3MHz (ceramic resonator oscillation) •Refer to figure 1	2.5 - 6.0	2.94	3	3.06	
	FmRC		RC oscillation	2.5 - 6.0	0.4	0.8	3.0	
	FsXtal	XT1, XT2	•32.768kHz (X'tal oscillation) •Refer to figure 2	2.5 - 6.0		32.768		kHz
Oscillation stabilizing time period (Note 1)	tmsCF(1)	CF1,CF2	•12MHz (ceramic resonator oscillation) •Refer to figure 3	4.5 - 6.0		0.02	0.2	ms
	tmsCF(2)	CF1,CF2	•3MHz (ceramic resonator oscillation) •Refer to figure 3	4.5 - 6.0		0.1	1	
				2.5 - 6.0		0.1	3	
tssXtal	XT1, XT2	•32.768kHz (X'tal oscillation) •Refer to figure 3	4.5 - 6.0		1	1.5	s	
			2.5 - 6.0		1	3		

(Note 1) The oscillation constant is shown on table 1 and table 2.

3. Electrical Characteristics at Ta=-30°C to +70°C, VSS=0V

Parameter	Symbol	Pins	Conditions	Ratings			unit	
				VDD[V]	min.	typ.		max.
Input high current	IIH(1)	•Port 1 •Port 0 without pullup MOS Tr.	•Output disable •Pull-up MOS Tr. OFF •VIN=VDD (including the off-leak current of the output Tr.)	2.5 - 6.0			1	μA
	IIH(2)	•Port 7 without pullup MOS Tr. •Port 8	VIN=VDD	2.5 - 6.0			1	
	IIH(3)	$\overline{\text{RES}}$	VIN=VDD	2.5 - 6.0			1	
Input low current	IIL(1)	•Port 1 •Port 0 without pullup MOS Tr.	•Output disable •Pull-up MOS Tr. OFF •VIN=VSS (including the off-leak current of the output Tr.)	2.5 - 6.0	-1			V
	IIL(2)	•Port 7 without pullup MOS Tr. •Port 8	VIN=VSS	2.5 - 6.0	-1			
	IIL(3)	$\overline{\text{RES}}$	VIN=VSS	2.5 - 6.0	-1			
Output high voltage	VOH(1)	CMOS output of ports 0, 1	IOH=-1.0mA	4.5 - 6.0	VDD-1			V
	VOH(2)		IOH=-0.1mA	2.5 - 6.0	VDD-0.5			
	VOH(3)	S0/T0 to S15/T15	IOH=-20mA	4.5 - 6.0	VDD-1.8			
	VOH(4)		•IOH=-1.0mA •The current of each pin is not over 1mA	2.5 - 6.0	VDD-1			
	VOH(5)	S16 to S29	IOH=-5mA	4.5 - 6.0	VDD-1.8			
	VOH(6)		•IOH=-1.0mA •The current of each pin is not over 1mA	2.5 - 6.0	VDD-1			
Output low voltage	VOL(1)	Ports 0, 1	IOL=10mA	4.5 - 6.0			1.5	KΩ
	VOL(2)		•IOL=1.6mA •The total current of the ports 0,1 is not over 40mA	4.5 - 6.0			0.4	
	VOL(3)		•IOL=-1.0mA •The current of each pin is not over 1mA	2.5 - 6.0			0.4	
	VOL(4)	Port 70	IOL=1mA	4.5 - 6.0			0.4	
	VOL(5)		IOL=0.5mA	2.5 - 6.0			0.4	
Pull-up MOS Tr. resistance	Rpu	•Ports 0, 1 •Port 7	VOH=0.9VDD	4.5 - 6.0	15	40	70	KΩ
			VOH=0.9VDD	2.5 - 4.5	25	70	150	
Output off-leakage current	IOFF(1)	•S0/T0 to S6/T6 •S16 to S29 (Without pull down resistor.)	•Output P-channel Tr. OFF •VOUT=VSS	2.5 - 6.0	-1			μA
	IOFF(2)		•Output P-channel Tr. OFF •VOUT=VDD-40V	2.5 - 6.0	-30			
Pulldown transistor resistor	Rpd	•S0/T0 to S15/T15 •S16 to S29 (With pull down resistor.)	•Output P-channel Tr. OFF •VOUT=3V •Vp=-30V	5.0	60	100	200	kΩ
Hysteresis voltage	VHIS	•Ports 0, 1 •Port 7 • $\overline{\text{RES}}$	Output disable	2.5 - 6.0		0.1VDD		V
Pin capacitance	CP	All pins	•f=1MHz •Terminals other than unloaded terminals set to VIN=VSS •Ta=25°C	2.5 - 6.0		10		pF

4. Serial Input/Output Characteristics at Ta=-30°C to +70°C, VSS=0V

Parameter	Symbol	Pins	Conditions	Ratings			unit		
				VDD[V]	min.	typ.		max.	
Serial clock	Input clock	Cycle	tCKCY(1)	SCK0, SCK1	Refer to figure 5.	2.5 - 6.0	2		tCYC
		Low Level pulse width	tCKL(1)				1		
		High Level pulse width	tCKH(1)				1		
	Output clock	Cycle	tCKCY(2)	SCK0, SCK1	•Use a pull-up resistor (1kΩ) when an open drain output. •Refer to figure 5	2.5 - 6.0	2		
		Low Level pulse width	tCKL(2)					1/2tCKCY	
		High Level pulse width	tCKH(2)					1/2tCKCY	
Serial input	Data set up time	tICK	•SI0, SI1 •SB0,SB1	•Data set-up to SCK0, 1. •Data hold from SCK0, 1. •Refer to figure 5.	4.5 - 6.0	0.1		μs	
					2.5 - 6.0	0.4			
	Data hold time	tCKI			4.5 - 6.0	0.1			
					2.5 - 6.0	0.4			
Serial output	Output delay time (External serial clock)	tCKO(1)	•SO0, SO1 •SB0,SB1	•Use a pull-up resistor (1kΩ) when an open drain output. •Data set-up to SCK0, 1 falling •Data hold from SCK0, 1 falling •Refer to figure 5	4.5 - 6.0			7/12tCYC +0.2	
					2.5 - 6.0			7/12tCYC +1	
	Output delay time (Internal serial clock)	tCKO(2)			4.5 - 6.0			1/3tCYC +0.2	
					2.5 - 6.0			1/3tCYC +1	

5. Pulse Input Conditions at Ta=-30°C to +70°C, VSS=0V

Parameter	Symbol	Pins	Conditions	Ratings			unit	
				VDD[V]	min.	typ.		max.
High/low level pulse width	tPIH(1)	•INT0, INT1	•Interrupt acceptable •Timer0-countable	2.5 - 6.0	1			tCYC
	tPIL(1)	•INT2/T0IN						
	tPIH(2)	INT3/T0IN	•Interrupt acceptable •Timer0-countable	2.5 - 6.0	2			
	tPIL(2)	(The noise rejection clock is selected to 1/1.)						
tPIH(3)	INT3/T0IN	•Interrupt acceptable •Timer0-countable	2.5 - 6.0	128				
tPIL(3)	(The noise rejection clock is selected to 1/64.)							
	tPIL(4)	RES	Reset acceptable	2.5 - 6.0	200			μs

6. AD Converter Characteristics at Ta=-30°C to +70°C, VSS=0V

Parameter	Symbol	Pins	Conditions	Ratings			unit	
				VDD[V]	min.	typ.		max.
Resolution	N			4.5 - 6.0		8	bit	
Absolute precision	ET		(Note 2)			±1.5	LSB	
Conversion time	tCAD		AD conversion time = 16 × tCYC (ADCR2=0) (Note 3)		15.68 (tCYC= 0.98μs)		65.28 (tCYC= 4.08μs)	μs
			AD conversion time = 32 × tCYC (ADCR2=1) (Note 3)		31.36 (tCYC= 0.98μs)		130.56 (tCYC= 4.08μs)	
Analog input voltage range	VAIN	AN0 - AN3		4.5 - 6.0	VSS		VDD	V
Analog port input current	IAINH		VAIN=VDD	4.5 - 6.0			1	μA
	IAINL		VAIN=VSS	4.5 - 6.0	-1			

(Note 2) Absolute precision excepts quantizing error ($\pm 1/2$ LSB).

(Note 3) The conversion time means the time from executing the AD conversion instruction to setting the complete digital conversion value to the register.

7. Current Dissipation Characteristics at Ta=-30°C to +70°C, VSS=0V

Parameter	Symbol	Pins	Conditions	Ratings			unit	
				VDD[V]	min.	typ.		max.
Current dissipation during basic operation (Note 4)	IDDOP(1)	VDD	<ul style="list-style-type: none"> •FmCF=12MHz Ceramic resonator oscillation •FsX'tal=32.768kHz crystal oscillation •System clock : CF oscillation •Internal RC oscillation stops 	4.5 - 6.0		10	20	mA
	IDDOP(2)		<ul style="list-style-type: none"> •FmCF=3MHz Ceramic resonator oscillation •FsX'tal=32.768kHz crystal oscillation •System clock : CF oscillation •Internal RC oscillation stops 	4.5 - 6.0		3	6	
	IDDOP(3)		<ul style="list-style-type: none"> •FmCF=3MHz Ceramic resonator oscillation •FsX'tal=32.768kHz crystal oscillation •System clock : CF oscillation •Internal RC oscillation stops 	2.5 - 4.5		1.5	5	
	IDDOP(4)		<ul style="list-style-type: none"> •FmCF=0Hz (When oscillation stops) •FsX'tal=32.768kHz crystal oscillation •System clock : RC oscillation 	4.5 - 6.0		0.7	1.4	
	IDDOP(5)		<ul style="list-style-type: none"> •FmCF=0Hz (When oscillation stops) •FsX'tal=32.768kHz crystal oscillation •System clock : RC oscillation 	2.5 - 4.5		0.4	1.2	
	IDDOP(6)		<ul style="list-style-type: none"> •FmCF=0Hz (When oscillation stops) •FsX'tal=32.768kHz crystal oscillation •System clock : 32.768kHz •Internal RC oscillation stops 	4.5 - 6.0		35	70	
	IDDOP(7)		<ul style="list-style-type: none"> •FmCF=0Hz (When oscillation stops) •FsX'tal=32.768kHz crystal oscillation •System clock : 32.768kHz •Internal RC oscillation stops 	2.5 - 4.5		15	50	

Continue.

Parameter	Symbol	Pins	Conditions	Ratings			unit	
				VDD[V]	min.	typ.		max.
Current dissipation in HALT mode (Note 4)	IDDHALT(1)	VDD	<ul style="list-style-type: none"> •HALT mode •FmCF=12MHz Ceramic resonator oscillation •FsX'tal=32.768kHz crystal oscillation •System clock : CF oscillation •Internal RC oscillation stops 	4.5 - 6.0		5	10	mA
	IDDHALT(2)		<ul style="list-style-type: none"> •HALT mode •FmCF=3MHz Ceramic resonator oscillation •FsX'tal=32.768kHz crystal oscillation •System clock : CF oscillation •Internal RC oscillation stops 	4.5 - 6.0		1.8	4.6	
	IDDHALT(3)		<ul style="list-style-type: none"> •HALT mode •FmCF=3MHz Ceramic resonator oscillation •FsX'tal=32.768kHz crystal oscillation •System clock : CF oscillation •Internal RC oscillation stops 	2.5 - 4.5		0.8	2.5	
	IDDHALT(4)		<ul style="list-style-type: none"> •HALT mode •FmCF=0Hz (When oscillation stops) •FsX'tal=32.768kHz crystal oscillation •System clock : RC oscillation 	4.5 - 6.0		400	800	μA
	IDDHALT(5)		<ul style="list-style-type: none"> •HALT mode •FmCF=0Hz (When oscillation stops) •FsX'tal=32.768kHz crystal oscillation •System clock : RC oscillation 	2.5 - 4.5		200	600	
	IDDHALT(6)		<ul style="list-style-type: none"> •HALT mode •FmCF=0Hz (When oscillation stops) •FsX'tal=32.768kHz crystal oscillation •System clock : 32.768kHz •Internal RC oscillation stops 	4.5 - 6.0		20	60	
	IDDHALT(7)		<ul style="list-style-type: none"> •HALT mode •FmCF=0Hz (When oscillation stops) •FsX'tal=32.768kHz crystal oscillation •System clock : 32.768kHz •Internal RC oscillation stops 	2.5 - 4.5		7	40	
Current dissipation in HOLD mode (Note 4)	IDDHOLD(1)	VDD	HOLD mode	4.5 - 6.0		0.05	30	
	IDDHOLD(2)			2.5 - 4.5		0.02	20	

(Note 4) The currents of the output transistors and the pull-up MOS transistors are ignored.

Table 1. Ceramic resonator oscillation recommended constant (main clock)

Oscillation type	Maker	Oscillator	C1	C2
12MHz ceramic resonator oscillation	Murata	CSA12.0MTZ	33pF	33pF
		CST12.0MTW	on chip	
	Kyocera	KBR-12.0M	33pF	33pF
3MHz ceramic resonator oscillation	Murata	CSA3.00MG	33pF	33pF
		CST3.00MGW	on chip	
	Kyocera	KBR-3.0MS	47pF	47pF

* Both C1 and C2 must use K rank ($\pm 10\%$) and SL characteristics.

Table 2. Crystal oscillation recommended constant (sub clock)

Oscillation type	Maker	Oscillator	C3	C4
32.768kHz crystal oscillation	Dai Sinky	DT-38(1TA252E00)	18pF	18pF
	Kyocera	KF-38G-13P0200	4pF	4pF

* Both C3 and C4 must use J rank ($\pm 5\%$) and CH characteristics.

(It is about the application which is not in need of high precision. Use K rank ($\pm 10\%$) and SL characteristics.)

- (Notes)
- Since the circuit pattern affects the oscillation frequency, place the oscillation-related parts as close to the oscillation pins as possible with the shortest possible pattern length.
 - If you use other oscillators herein, we provide no guarantee for the characteristics.

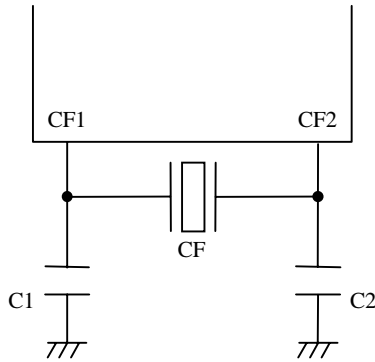

Figure 1 Main-clock circuit
Ceramic resonator oscillation

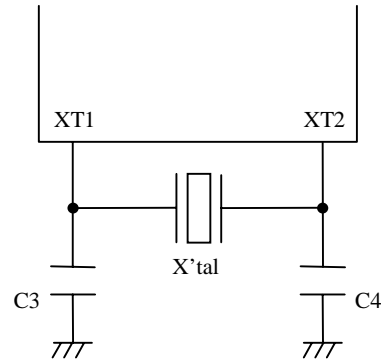

Figure 2 Sub-clock circuit
Crystal oscillation

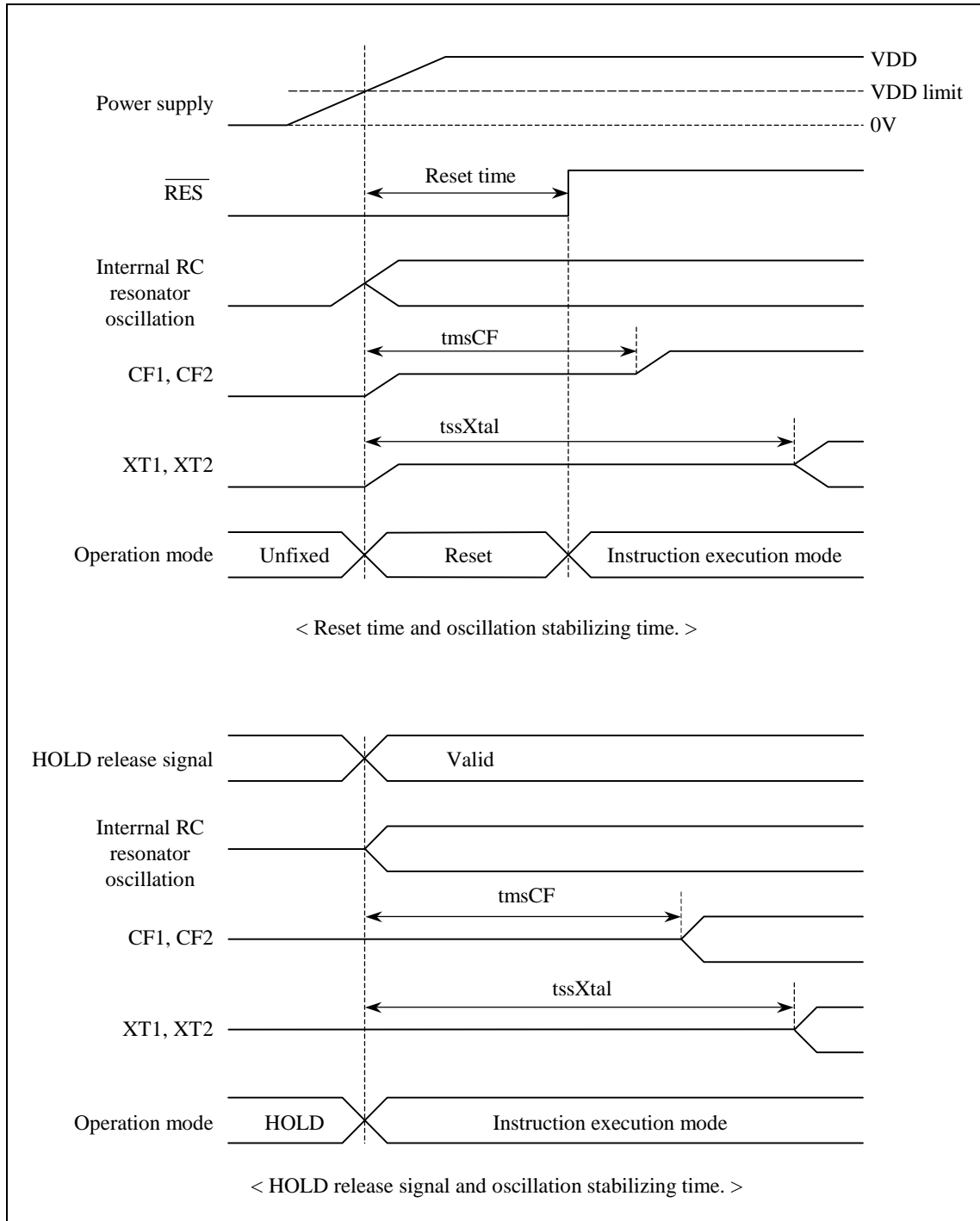
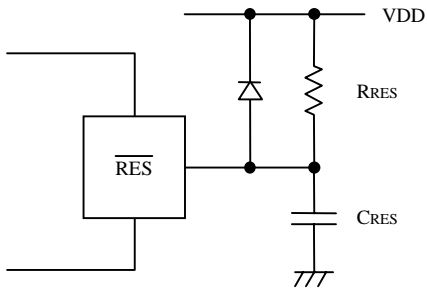

Figure 3 Oscillation stabilizing time



(Note) Fix the value of CRES, RRES that is sure to reset until 200 μ s, after Power supply has been over inferior limit of supply voltage.

Figure 4 Reset circuit

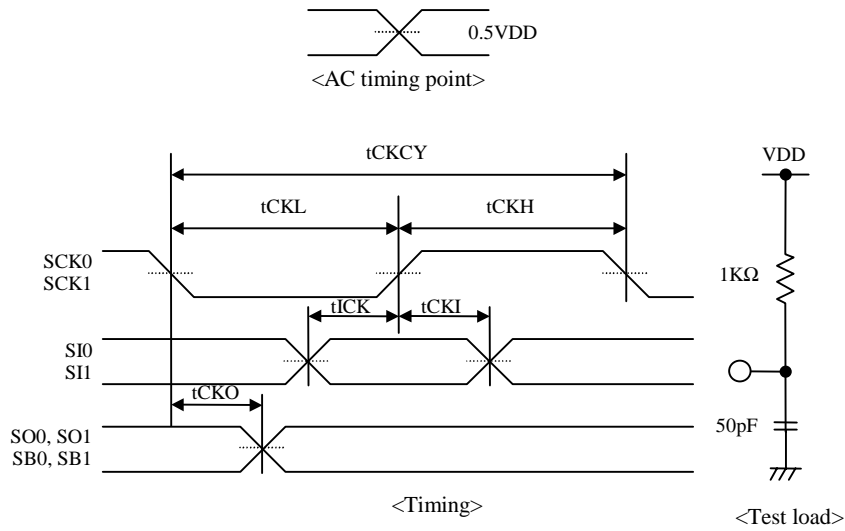

Figure 5 Serial input / output test condition

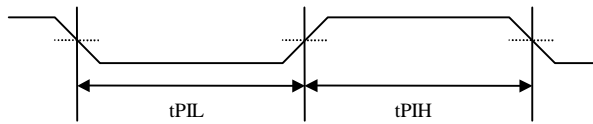

Figure 6 Pulse input timing condition

memo:

- Specifications of any and all SANYO products described or contained herein stipulate the performance, characteristics, and functions of the described products in the independent state, and are not guarantees of the performance, characteristics, and functions of the described products as mounted in the customer's products or equipment. To verify symptoms and states that cannot be evaluated in an independent device, the customer should always evaluate and test devices mounted in the customer's products or equipment.
- SANYO Electric Co., Ltd. strives to supply high-quality high-reliability products. However, any and all semiconductor products fail with some probability. It is possible that these probabilistic failures could give rise to accidents or events that could endanger human lives, that could give rise to smoke or fire, or that could cause damage to other property. When designing equipment, adopt safety measures so that these kinds of accidents or events cannot occur. Such measures include but are not limited to protective circuits and error prevention circuits for safe design, redundant design, and structural design.
- In the event that any or all SANYO products (including technical data, services) described or contained herein are controlled under any of applicable local export control laws and regulations, such products must not be exported without obtaining the export license from the authorities concerned in accordance with the above law.
- No part of this publication may be reproduced or transmitted in any form or by any means, electronic or mechanical, including photocopying and recording, or any information storage or retrieval system, or otherwise, without the prior written permission of SANYO Electric Co., Ltd.
- Any and all information described or contained herein are subject to change without notice due to product/technology improvement, etc. When designing equipment, refer to the "Delivery Specification" for the SANYO product that you intend to use.
- Information (including circuit diagrams and circuit parameters) herein is for example only ; it is not guaranteed for volume production. SANYO believes information herein is accurate and reliable, but no guarantees are made or implied regarding its use or any infringements of intellectual property rights or other rights of third parties.

This catalog provides information as of September, 2000. Specifications and information herein are subject to change without notice.