

# Specification

## HB601R

### CUSTOMER

Checked by	Approved by

### SUPPLIER

Drawn by	Approved by

# CONTENTS

1. **Description**
2. **Absolute maximum ratings**
3. **Electro-optical characteristics**
4. **Characteristic diagram**
5. **Rank**
6. **Material**
7. **Outline Dimension**
8. **Packing**
9. **Soldering**
10. **Precaution for use**

# HB601R

## HB601R

### 1. Description

- Small size suitable for compact appliances
- Surface-mounted and leadless chip LED device
- High brightness, wide variety of colors are available
- Tape and Reel packing
- Increases the life time of battery

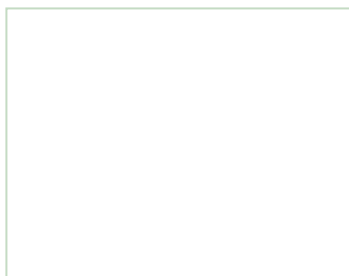

### Features

- 2.1 X 1.0 X 0.6 mm
- Side Type
- Wavelength : 470 nm

### Applications

- Cellular phone's keypad lightning
- Other decoration lighting

## 2. Absolute maximum ratings

(Ta=25℃)

Parameter	Symbol	Value	Unit
Power Dissipation	$P_d$	64	mW
Forward Current	$I_F$	20	mA
Peak Forward Current	$I_{FM}^{*1}$	50	mA
Reverse Voltage	$V_R$	5	V
Operation Temperature	$T_{opr.}$	-35 ~ 85	℃
Storage Temperature	$T_{stg.}$	-40 ~ 100	℃

\*1  $I_{FM}$  conditions: Pulse width  $T_w \leq 0.1ms$  and Duty ratio  $\leq 1/10$

## 3. Electro-Optical Characteristics

(Ta=25℃)

Parameter	Symbol	Condition	Min	Typ	Max	Unit
Forward Voltage	$V_F$	$I_F=5\text{ mA}$	2.7	3.05	3.2	V
Reverse Current	$I_R$	$V_R=5V$	-	-	10	$\mu A$
Luminous Intensity*2	$I_V$	$I_F=5\text{ mA}$	14	17	40	mcd
Wavelength	$\lambda_d$	$I_F=5\text{ mA}$	466	470	475	nm
Spectral Bandwidth	$\Delta\lambda$	$I_F=5\text{ mA}$	-	25	-	nm
Viewing Angle*3	$2\theta_{1/2}$	$I_F=5\text{ mA}$	-	120	-	°

\*2 The luminous intensity  $I_V$  is measured at the peak of the spatial pattern which may not be aligned with the mechanical axis of the LED package.

\*3  $\theta_{1/2}$  is the off-axis where the luminous intensity is 1/2 the peak intensity.

[Note] All products conform to the listed minimum and maximum specifications for electric and optical characteristics, when operated at 20mA within the maximum ratings shown above. All measurements were made under the standardized environment of SSC.

(Tolerance :  $I_V \pm 10\%$ ,  $\lambda_D \pm 2\text{ nm}$ ,  $V_F \pm 0.1\text{ V}$ )

### 4. Electro-Optical characteristic Diagram

Forward Current vs. Forward Voltage

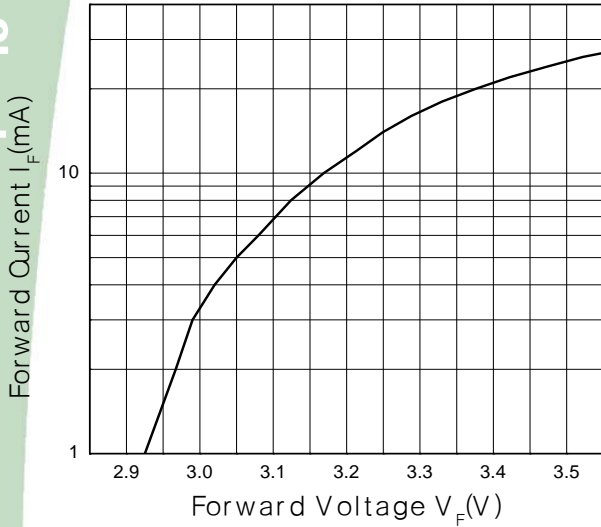

Relative Luminous Intensity vs Forward Current

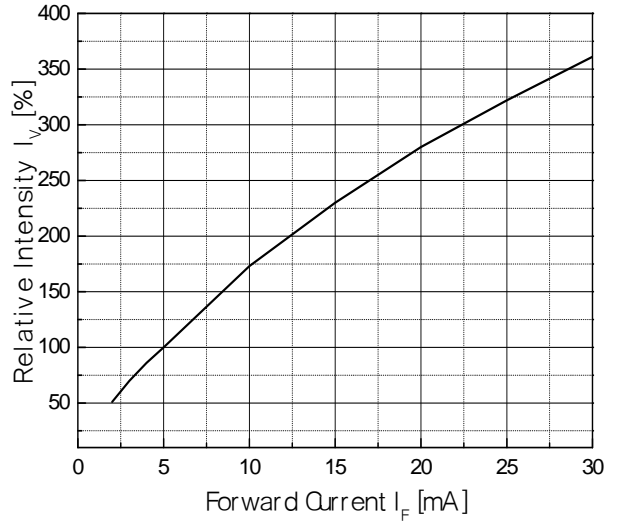

Ambient Temperature vs. Allowable Forward Current

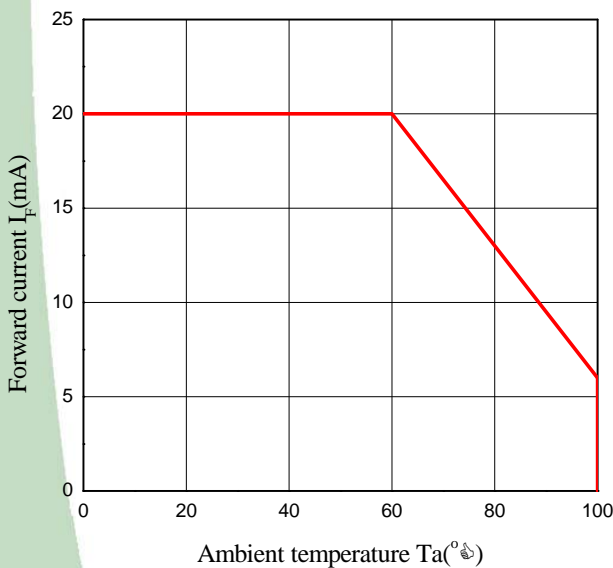

Radiation Diagram

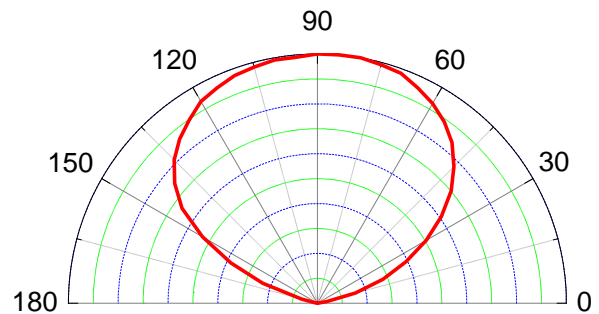

---

Spectrum

---

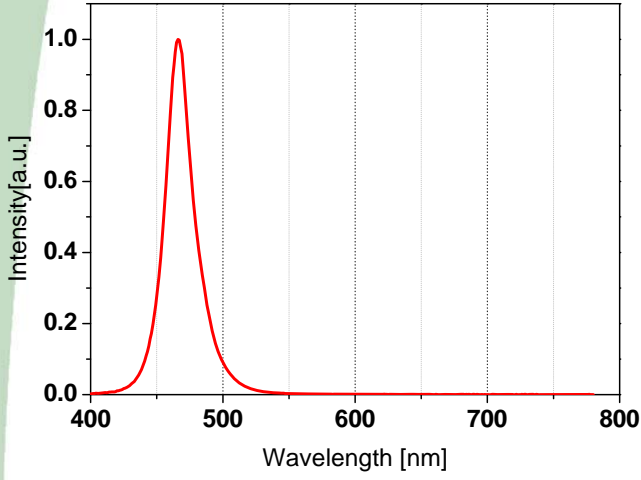

### 5. Rank

$V_F$ [V]	$I_V$ [mcd]	$\lambda_D$ [nm]	BIN
at $I_F=5$ [mA]	at $I_F=5$ [mA]	at $I_F=5$ [mA]	
2.7-2.9	14-23	466-469	1
2.9-3.2	14-23	466-469	2
2.7-2.9	14-23	469-472	3
2.9-3.2	14-23	469-472	4
2.7-2.9	14-23	472-475	5
2.9-3.2	14-23	472-475	6
2.7-2.9	23-40	466-469	7
2.9-3.2	23-40	466-469	8
2.7-2.9	23-40	469-472	9
2.9-3.2	23-40	469-472	10
2.7-2.9	23-40	472-475	11
2.9-3.2	23-40	472-475	12

### 6. Material

Item	PCB	Chip	wire	Encapsulate	Electrode
Material	BT-Resin	InGaN	Gold	Epoxy	Au

7. Outline Dimension

( Tolerance:  $\pm 0.1$ , Unit: mm )

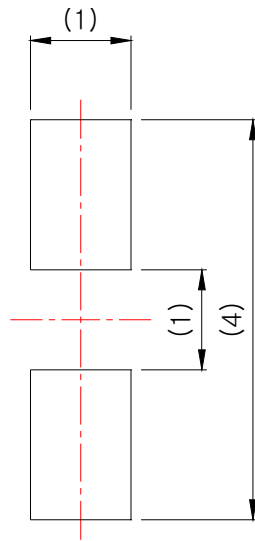
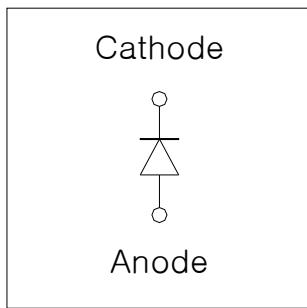
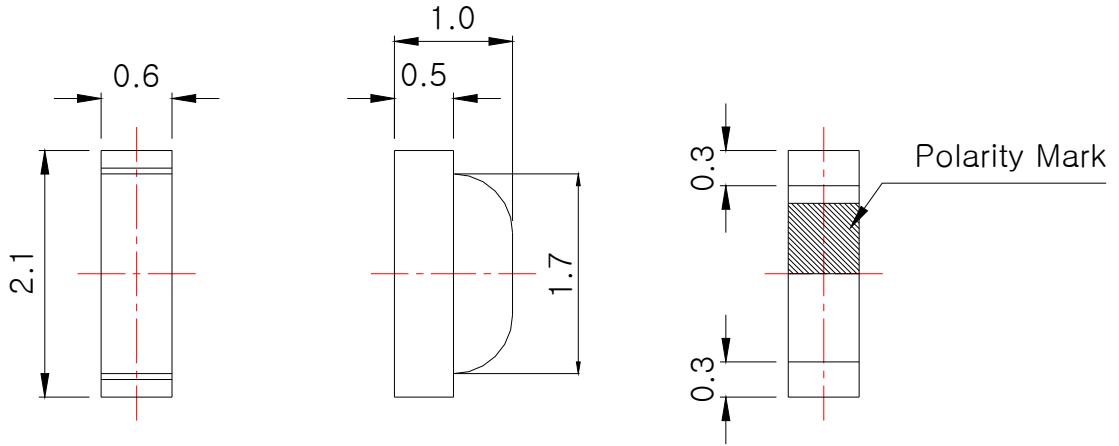

### 8. Packing

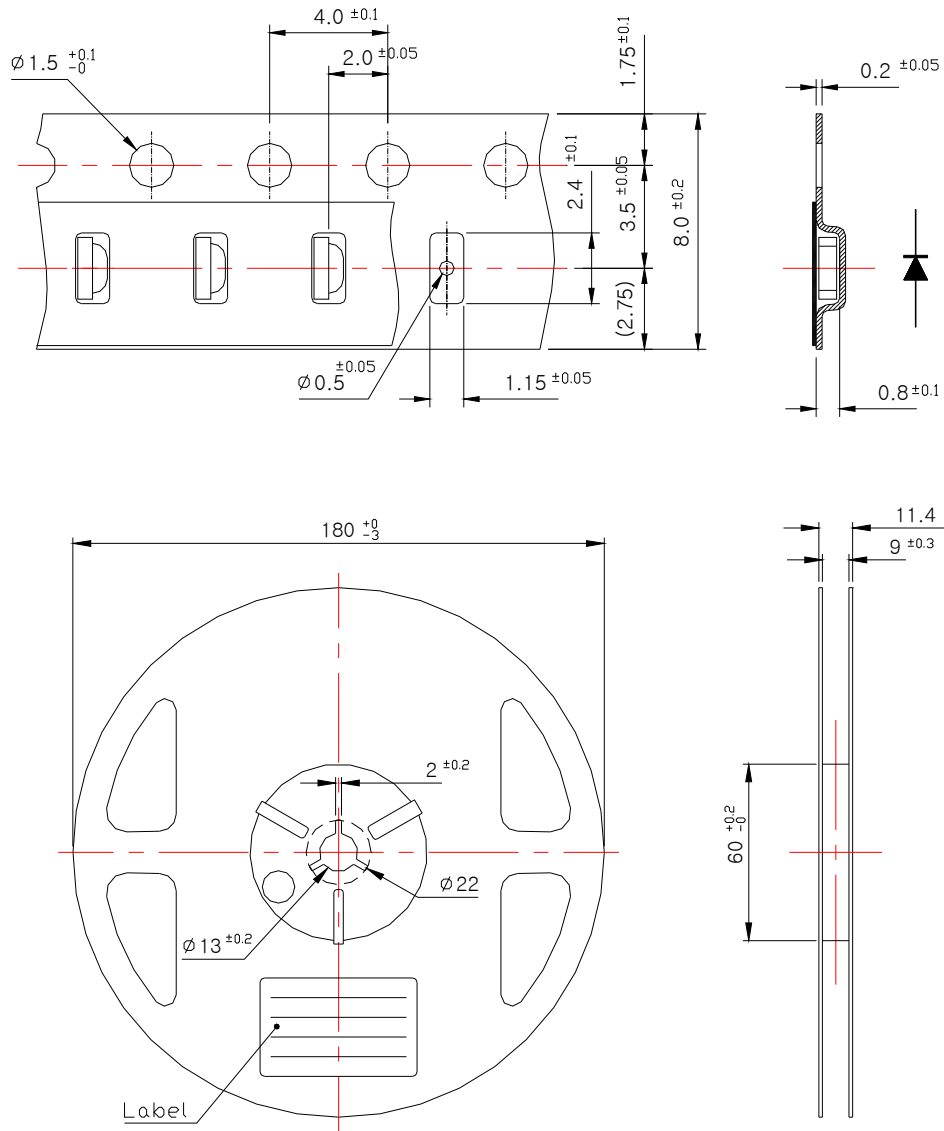

Tolerance:  $\pm 0.2$ , Unit: mm

- (1) Quantity: 3,000pcs./Reel
- (2) Cumulative Tolerance: Cumulative Tolerance/10pitches to be  $\pm 0.2$ mm
- (3) Adhesion Strength of Cover Tape: Adhesion strength to be 0.1-0.7N when the over tape is turned off from the carrier tape at  $10^\circ$  angle to be the carrier tape.
- (4) Package: P/N, Manufacturing data Code No. and quantity to be indicated on a damp proof Package.

● Reel Packing Structure

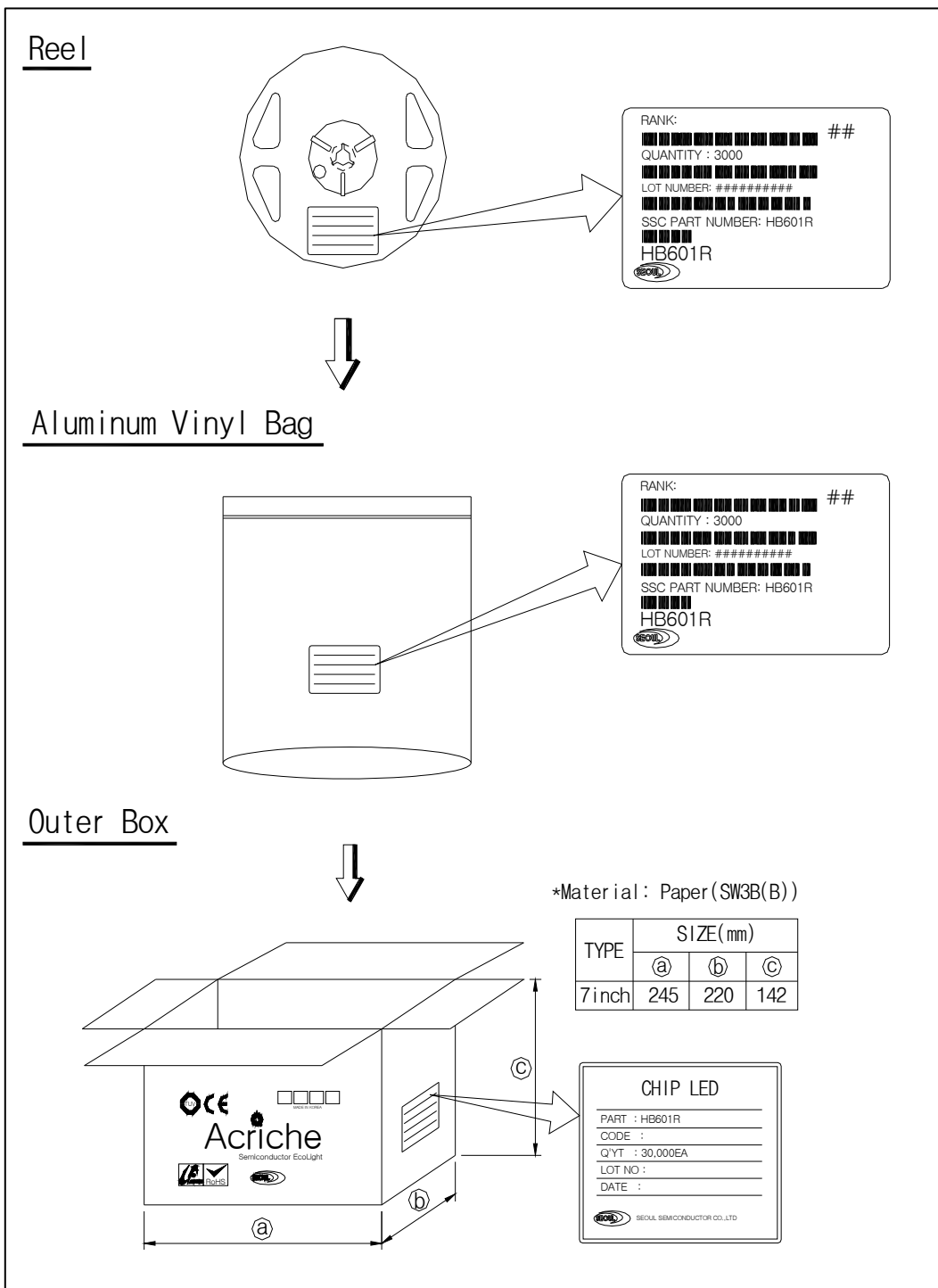

## 9 . Soldering

### (1) Lead Solder

Lead Solder	
Pre-heat	120 ~ 150 °C
Pre-heat time	120 sec. Max.
Peak-Temperature	240 °C Max.
Soldering time Condition	10 sec. Max.

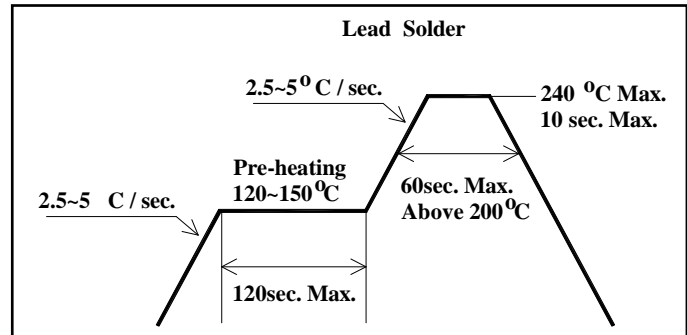

### (2) Lead-Free Solder

Lead Free Solder	
Pre-heat	150 ~ 200 °C
Pre-heat time	120 sec. Max.
Peak-Temperature	260 °C Max.
Soldering time Condition	10 sec. Max.

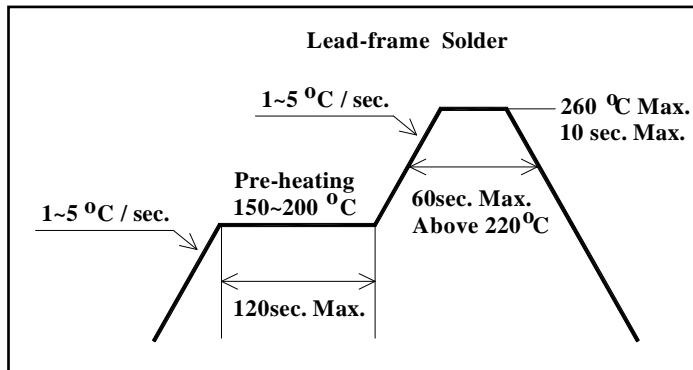

### (3) Hand Soldering conditions

Do not exceed 3 seconds at maximum 280°C under soldering iron.

Note : In case that the soldered products are reused in soldering process, we don't guarantee the products.

## 10. Precaution for use

### (1) Storage

In order to avoid the absorption of moisture, it is recommended to store in a dry box (or a desiccator) with a desiccant. Otherwise, to store them in the following environment is recommended.

Temperature : Max 30°C

Humidity : Max 65%RH

### (2) Attention after open.

LED is correspond to SMD, when LED be soldered dip, interfacial separation may affect the light transmission efficiency, causing the light intensity to drop. Attention in followed;

a. After opened and mounted the soldering shall be quickly.

b. Keeping of a fraction

Temperature : 5 ~ 40°C Humidity : less than 30%

(3) In the case of more than 1 week passed after opening or change color of indicator on desiccant, components shall be dried 10-12hr. at 60±5°C.

(4) Any mechanical force or any excess vibration shall not be accepted to apply during cooling process to normal temperature after soldering.

(5) Quick cooling shall be avoided.

(6) Components shall not be mounted on warped direction of PCB.

(7) Anti radioactive ray design is not considered for the products.

(8) This device should not be used in any type of fluid such as water, oil, organic solvent etc. When washing is required, IPA should be used.

(9) When the LEDs are illuminating, operating current should be decided after considering the ambient maximum temperature.

(10) LEDs must be stored to maintain a clean atmosphere. If the LEDs are stored for 3 months or more after being shipped from SSC, a sealed container with a nitrogen atmosphere should be used for storage.

(11) The LEDs must be soldered within seven days after opening the moisture-proof packing.

(12) Repack unused products with anti-moisture packing, fold to close any opening and then store in a dry place.

(13) The appearance and specifications of the product may be modified for improvement without notice.