

FOD073L

LVTTL/LVCMOS Compatible Low Input Current High Gain Split Darlington Optocoupler

Features

- Low power consumption
- Low input current: 0.5mA
- Dual channel 8-pin SOIC package
- High CTR: 400% minimum
- High CMR: 10kV/μs
- Guaranteed performance over temperature 0°C to 70°C
- U.L. recognized (File # E90700)
- LVTTL/LVCMOS Compatible output

Applications

- Digital logic ground isolation – LVTTL/LVCMOS
- Telephone ring detector
- EIA-RS-232C line receiver
- High common mode noise line receiver
- μP bus isolation
- Current loop receiver

Description

The FOD073L optocoupler consists of an AlGaAs LED optically coupled to a high gain split darlington photo-detector. This device is specified to operate at a 3.3V supply voltage.

An integrated emitter – base resistor provides superior stability over temperature.

The combination of a very low input current of 0.5mA and a high current transfer ratio of 2000% (typical) makes this device particularly useful for input interface to MOS, CMOS, LSTTL and EIA RS232C, while output compatibility is ensured to LVCMOS as well as high fan-out LVTTL requirements.

An internal noise shield provides exceptional common mode rejection of 10kV/μs.

Schematic

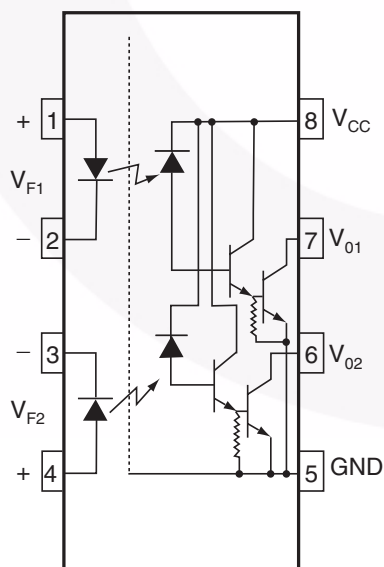

Package Outline

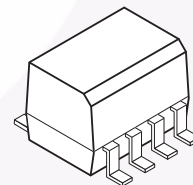

Truth Table

LED	V _O
ON	LOW
OFF	HIGH

Absolute Maximum Ratings (No derating required up to 85°C)

Stresses exceeding the absolute maximum ratings may damage the device. The device may not function or be operable above the recommended operating conditions and stressing the parts to these levels is not recommended. In addition, extended exposure to stresses above the recommended operating conditions may affect device reliability. The absolute maximum ratings are stress ratings only.

Symbol	Parameter		Value	Units
T _{STG}	Storage Temperature		-40 to +125	°C
T _{OPR}	Operating Temperature		-40 to +85	°C
T _{SOL}	Lead Solder Temperature (Wave solder only. See reflow profile for surface mount devices)		260 for 10 sec	°C
EMITTER				
I _F (avg)	DC/Average Forward Input Current	Each Channel	20	mA
I _F (pk)	Peak Forward Input Current (50% duty cycle, 1ms P.W.)	Each Channel	40	mA
I _F (trans)	Peak Transient Input Current (≤1μs P. W., 300 pps)	Each Channel	1.0	A
V _R	Reverse Input Voltage	Each Channel	5	V
P _D	Input Power Dissipation	Each Channel	35	mW
DETECTOR				
I _O (avg)	Average Output Current	Each Channel	60	mA
V _{EB}	Emitter-Base Reverse Voltage (FOD070L, FOD270L)	Each Channel	0.5	V
V _{CC} , V _O	Supply Voltage, Output Voltage	Each Channel	-0.5 to 7	V
P _D	Output power dissipation	Each Channel	100	mW

Electrical Characteristics (T_A = 0 to 70°C unless otherwise specified)

Individual Component Characteristics

Symbol	Parameter	Test Conditions	Min.	Typ.*	Max.	Unit
EMITTER						
V _F	Input Forward Voltage	T _A = 25°C I _F = 1.6mA (Each Channel)		1.35	1.7	V
BV _R	Input Reverse Breakdown Voltage	T _A = 25°C, I _R = 10μA (Each Channel)	5.0		1.75	V
DETECTOR						
I _{OH}	Logic High Output Current	I _F = 0 mA, V _O = V _{CC} = 3.3V (Each Channel)		0.05	25	μA
I _{CCL}	Logic Low Supply Current	I _{F1} = I _{F2} = 1.6mA, V _{O1} = V _{O2} = Open, V _{CC} = 3.3V		0.8	3	mA
I _{CCH}	Logic High Supply Current	I _{F1} = I _{F2} = 0mA, V _{O1} = V _{O2} = Open, V _{CC} = 3.3V		0.01	2	μA

Transfer Characteristics

Symbol	Parameter	Test Conditions	Min.	Typ.*	Max.	Unit
CTR	COUPLED Current Transfer Ratio (Note 1)	I _F = 0.5mA, V _O = 0.4V, V _{CC} = 3.3V	400		7000	%
V _{OL}	Logic Low Output Voltage	I _F = 1.6mA, I _O = 8mA, V _{CC} = 3.3V		0.07	0.3	V
		I _F = 5mA, I _O = 15mA, V _{CC} = 3.3V		0.07	0.4	

Switching Characteristics (V_{CC} = 3.3 V)

Symbol	Parameter	Test Conditions	Min.	Typ.*	Max.	Unit
T _{PHL}	Propagation Delay Time to Logic LOW	R _L = 4.7kΩ, I _F = 0.5mA (Fig. 9)		5	30	μs
T _{PLH}	Propagation Delay Time to Logic HIGH	R _L = 4.7kΩ, I _F = 0.5mA (Fig. 9)		25	90	μs
ICM _H I	Common Mode Transient Immunity at Logic HIGH	I _F = 0 mA, V _{CM} = 10 V _{P-P} , T _A = 25°C, R _L = 2.2kΩ (Note 2) (Fig. 10)	1,000	10,000		V/μs
ICM _L I	Common Mode Transient Immunity at Logic LOW	I _F = 1.6mA, V _{CM} = 10 V _{P-P} , R _L = 2.2kΩ, T _A = 25°C (Note 2) (Fig. 10)	1,000	10,000		V/μs

*All typicals at T_A = 25°C

Electrical Characteristics (Continued) ($T_A = 0$ to 70°C unless otherwise specified)**Isolation Characteristics**

Symbol	Characteristics	Test Conditions	Min.	Typ.*	Max.	Unit
I_{I-O}	Input-Output Insulation Leakage Current	Relative humidity = 45%, $T_A = 25^\circ\text{C}$, $t = 5$ s, $V_{I-O} = 3000$ VDC (Note 3)			1.0	μA
V_{ISO}	Withstand Insulation Test Voltage	$R_H \leq 50\%$, $T_A = 25^\circ\text{C}$, $I_{I-O} \leq 2\mu\text{A}$, $t = 1$ min. (Note 3)	2500			V_{RMS}
R_{I-O}	Resistance (Input to Output)	$V_{I-O} = 500$ VDC (Note 3)		10^{12}		Ω
C_{I-O}	Capacitance (Input to Output)	$f = 1$ MHz (Notes 3, 4)		0.7		pF
I_{I-I}	Input-Input Insulation Leakage Current	$R_H \leq 45\%$, $V_{I-I} = 500$ VDC (Note 5)	0.005			μA
R_{I-I}	Input-Input Resistance	$V_{I-I} = 500$ VDC (Note 5)		10^{11}		Ω
C_{I-I}	Input-Input Capacitance	$f = 1$ MHz (Note 5)		0.03		pF

*All typicals at $T_A = 25^\circ\text{C}$

Notes:

1. Current Transfer Ratio is defined as a ratio of output collector current, I_O , to the forward LED input current, I_F , times 100%.
2. Common mode transient immunity in logic high level is the maximum tolerable (positive) dV_{CM}/dt on the leading edge of the common mode pulse signal, V_{CM} , to assure that the output will remain in a logic high state (i.e., $V_O > 2.0\text{V}$). Common mode transient immunity in logic low level is the maximum tolerable (negative) dV_{CM}/dt on the trailing edge of the common mode pulse signal, V_{CM} , to assure that the output will remain in a logic low state (i.e., $V_O < 0.8\text{V}$).
3. Device is considered a two terminal device: Pins 1, 2, 3 and 4 are shorted together and Pins 5, 6, 7 and 8 are shorted together.
4. CI-O is measured by shorting pins 1 and 2 or pins 3 and 4 together and pins 5 through 8 shorted together.
5. Measured between pins 1 and 2 shorted together, and pins 3 and 4 shorted together.

Typical Performance Curves

Fig. 1 Input Forward Current vs Forward Voltage

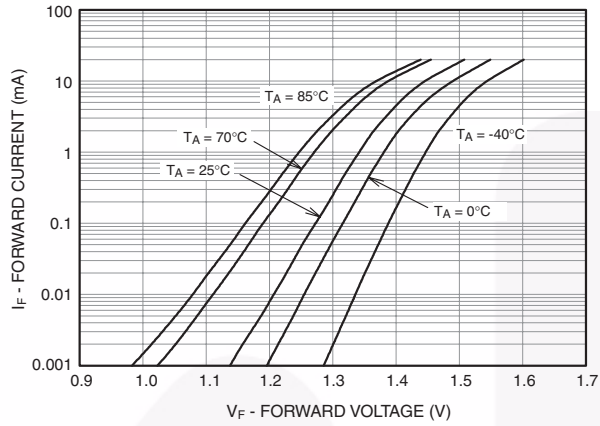

Fig. 2 Current Transfer Ratio vs. Input Forward Current

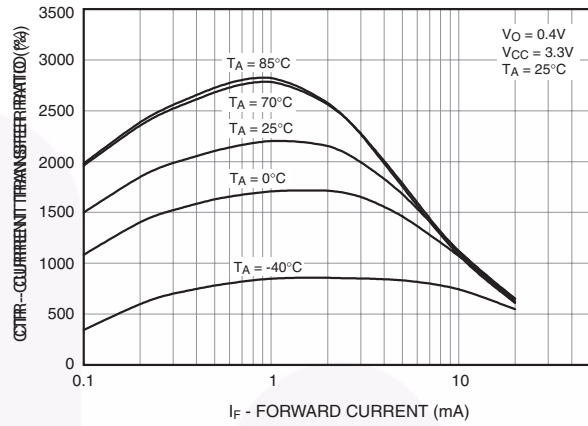

Fig. 3 DC Transfer Characteristics

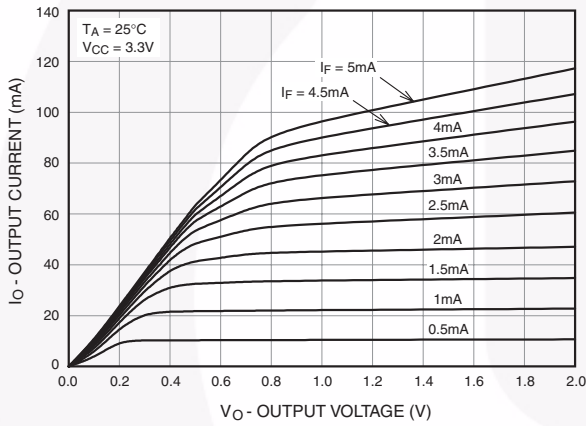

Fig. 4 Supply Current vs Input Forward Current

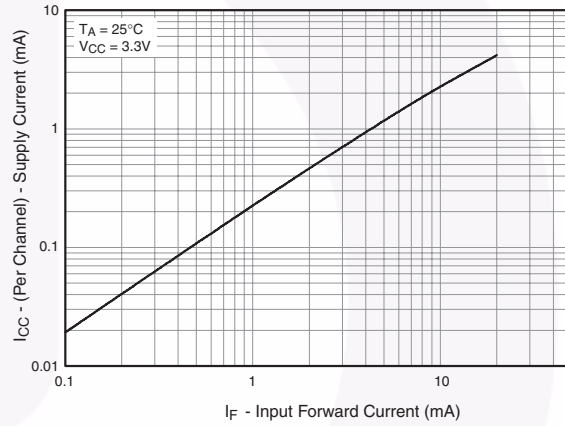

Fig. 5 Output Current vs Input Forward Current

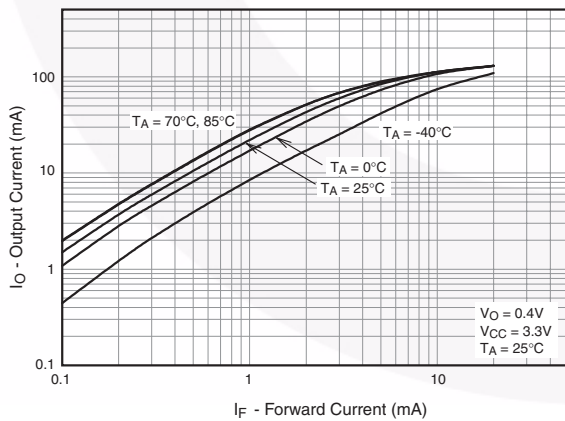
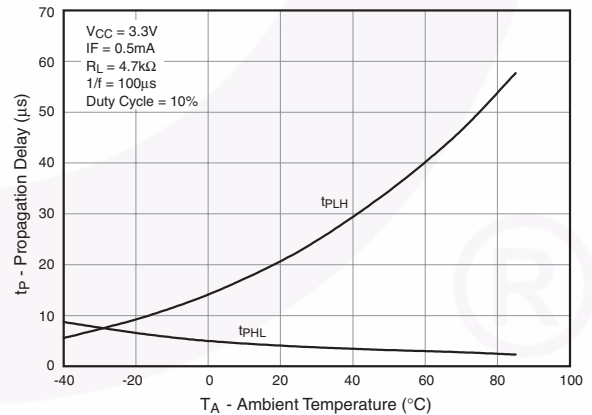

Fig. 6 Propagation Delay vs. Ambient Temperature



Typical Performance Curves (Continued)

Fig. 7 Propagation Delay To Logic Low vs Pulse Period

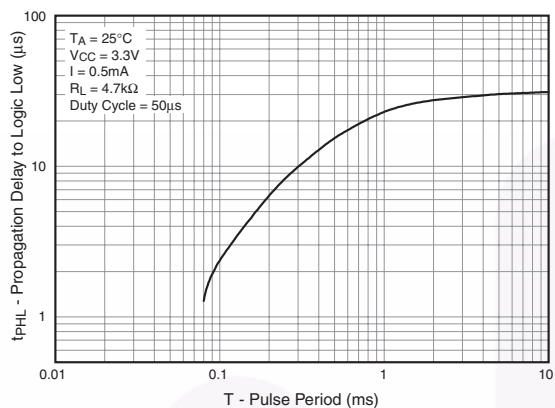
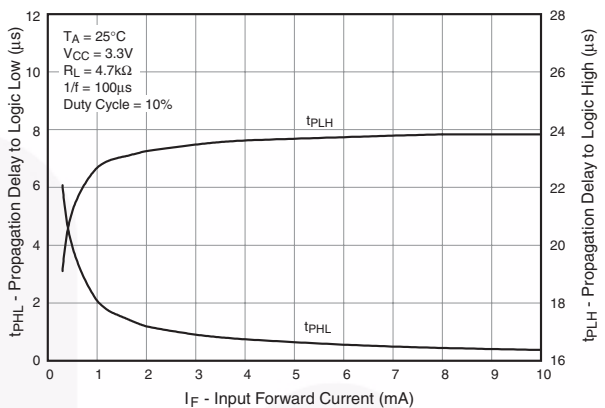

Fig. 8 Propagation Delay vs. Input Forward Current



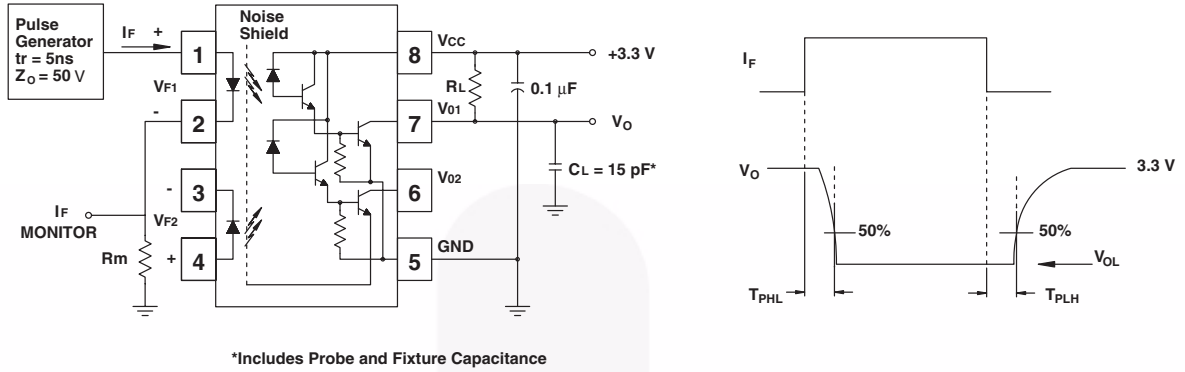

Fig. 9 Switching Time Test Circuit

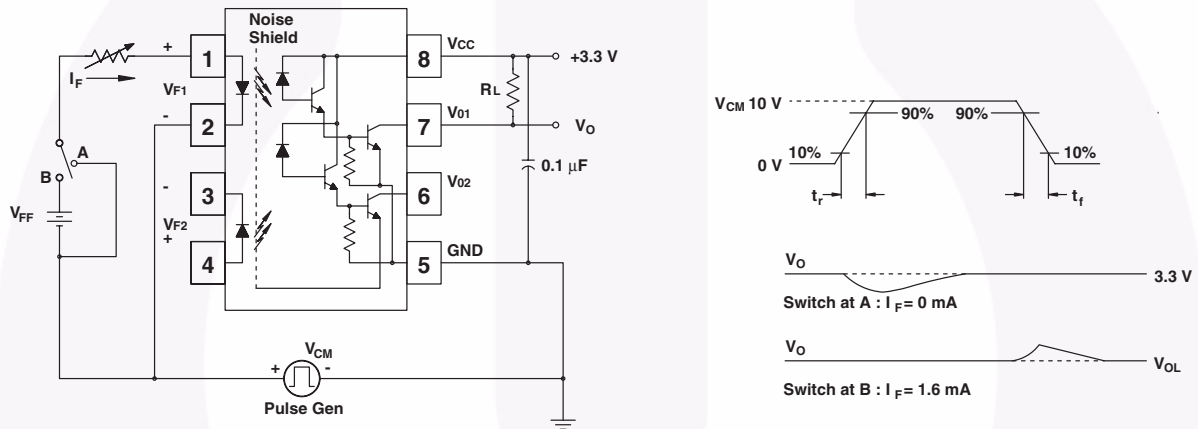
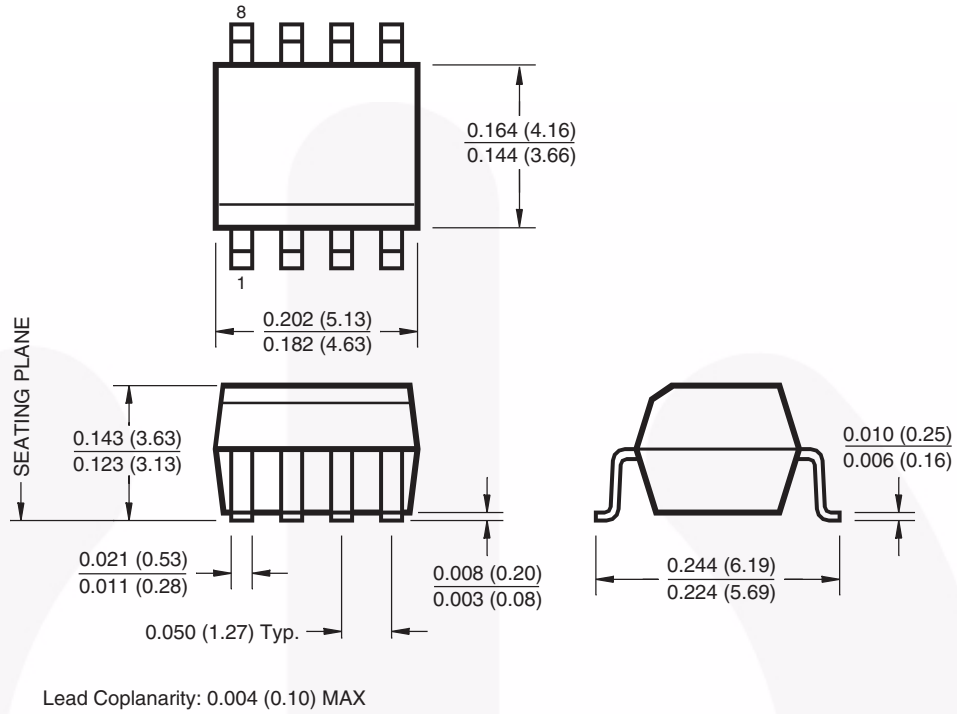

Fig. 10 Common Mode Immunity Test Circuit

Package Dimensions

8-pin SOIC Surface Mount



Recommended Pad Layout

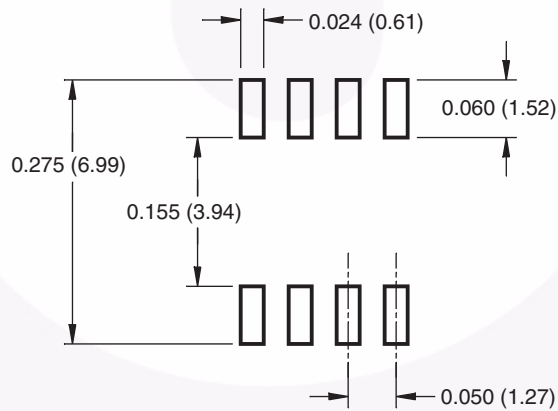

Dimensions in inches (mm).

Package drawings are provided as a service to customers considering Fairchild components. Drawings may change in any manner without notice. Please note the revision and/or date on the drawing and contact a Fairchild Semiconductor representative to verify or obtain the most recent revision. Package specifications do not expand the terms of Fairchild's worldwide terms and conditions, specifically the warranty therein, which covers Fairchild products.

Always visit Fairchild Semiconductor's online packaging area for the most recent package drawings:

<http://www.fairchildsemi.com/packaging/>

Ordering Information

Option	Order Entry Identifier	Description
No Suffix	FOD073L	Shipped in tubes (50 units per tube)
R2	FOD073LR2	Tape and reel (2,500 units per reel)

Marking Information

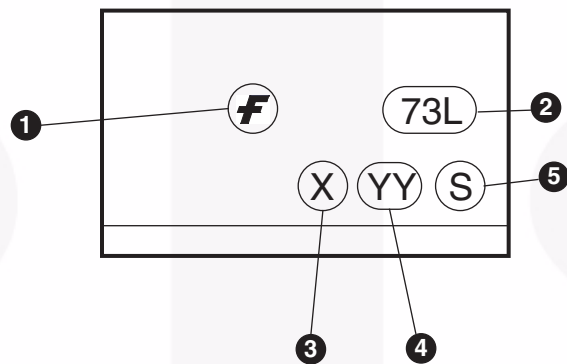

Definitions	
1	Fairchild logo
2	Device number
3	One digit year code, e.g., '3'
4	Two digit work week ranging from '01' to '53'
5	Assembly package code

Carrier Tape Specifications

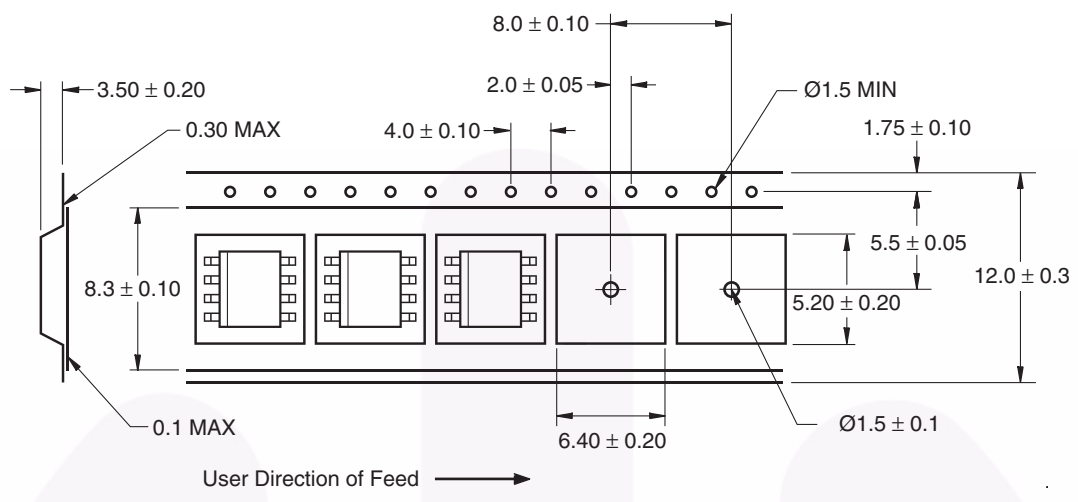

Reflow Profile

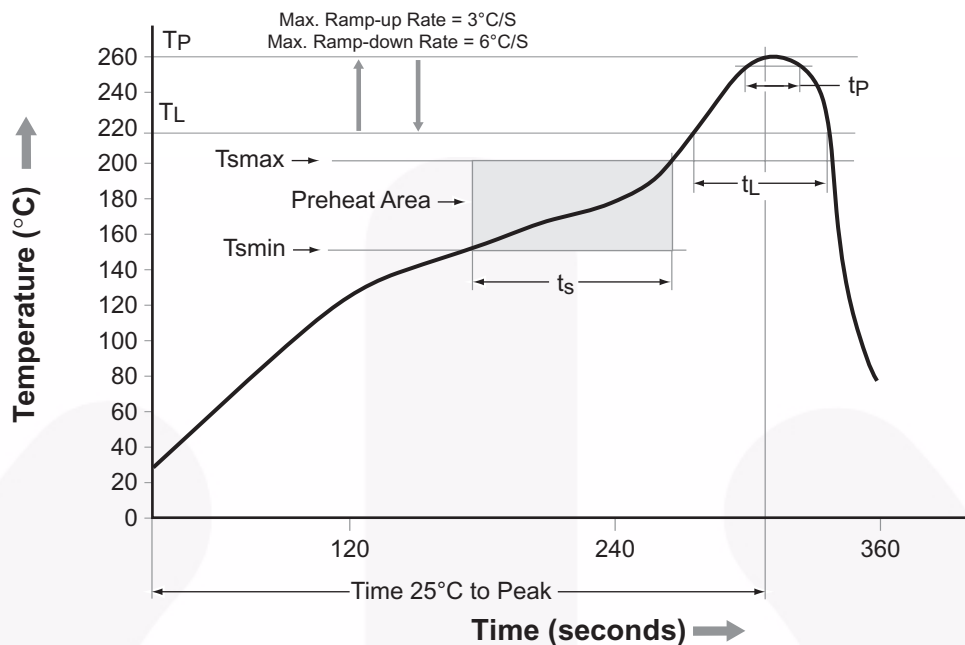







Profile Feature	Pb-Free Assembly Profile
Temperature Min. (T _{smín})	150°C
Temperature Max. (T _{smáx})	200°C
Time (t _s) from (T _{smín} to T _{smáx})	60–120 seconds
Ramp-up Rate (t _L to t _p)	3°C/second max.
Liquidous Temperature (T _L)	217°C
Time (t _L) Maintained Above (T _L)	60–150 seconds
Peak Body Package Temperature	260°C +0°C / -5°C
Time (t _p) within 5°C of 260°C	30 seconds
Ramp-down Rate (T _p to T _L)	6°C/second max.
Time 25°C to Peak Temperature	8 minutes max.



TRADEMARKS

The following includes registered and unregistered trademarks and service marks, owned by Fairchild Semiconductor and/or its global subsidiaries, and is not intended to be an exhaustive list of all such trademarks.

- | | | | |
|--|---|--|---|
| Auto-SPM™ | F-PFS™ | PowerTrench® | The Power Franchise® |
| Build it Now™ | FRFET® | PowerXS™ | the power franchise |
| CorePLUS™ | Global Power Resource™ | Programmable Active Droop™ | QFET™ |
| CorePOWER™ | Green FPS™ | QFET™ | TinyBoost™ |
| CROSSVOLT™ | Green FPS™ e-Series™ | QS™ | TinyBuck™ |
| CTL™ | Gmax™ | Quiet Series™ | TinyLogic® |
| Current Transfer Logic™ | GTO™ | RapidConfigure™ | TINYOPTO™ |
| EcoSPARK® | IntelliMAX™ |  ™ | TinyPower™ |
| EfficientMax™ | ISOPLANAR™ | Saving our world, 1mW/W/kW at a time™ | TinyPWM™ |
| EZSWITCH™* | MegaBuck™ | SmartMax™ | TinyWire™ |
|  ™* | MICROCOUPLER™ | SMART START™ | TriFault Detect™ |
|  ® | MicroFET™ | SPM® | TRUECURRENT™* |
| Fairchild® | MicroPak™ | STEALTH™ | μSerDes™ |
| Fairchild Semiconductor® | MillerDrive™ | SuperFET™ |  ™ |
| FACT Quiet Series™ | MotionMax™ | SuperSOT™-3 | UHC® |
| FACT® | Motion-SPM™ | SuperSOT™-6 | Ultra FRFET™ |
| FAST® | OPTOLOGIC® | SuperSOT™-8 | UniFET™ |
| FastvCore™ | OPTOPLANAR® | SupreMOS™ | VCX™ |
| FETBench™ |  | SyncFET™ | VisualMax™ |
| FlashWriter®* | PDP SPM™ | Sync-Lock™ | XS™ |
| FPS™ | Power-SPM™ |  ®* | |

* Trademarks of System General Corporation, used under license by Fairchild Semiconductor.

DISCLAIMER

FAIRCHILD SEMICONDUCTOR RESERVES THE RIGHT TO MAKE CHANGES WITHOUT FURTHER NOTICE TO ANY PRODUCTS HEREIN TO IMPROVE RELIABILITY, FUNCTION, OR DESIGN. FAIRCHILD DOES NOT ASSUME ANY LIABILITY ARISING OUT OF THE APPLICATION OR USE OF ANY PRODUCT OR CIRCUIT DESCRIBED HEREIN; NEITHER DOES IT CONVEY ANY LICENSE UNDER ITS PATENT RIGHTS, NOR THE RIGHTS OF OTHERS. THESE SPECIFICATIONS DO NOT EXPAND THE TERMS OF FAIRCHILD'S WORLDWIDE TERMS AND CONDITIONS, SPECIFICALLY THE WARRANTY THEREIN, WHICH COVERS THESE PRODUCTS.

LIFE SUPPORT POLICY

FAIRCHILD'S PRODUCTS ARE NOT AUTHORIZED FOR USE AS CRITICAL COMPONENTS IN LIFE SUPPORT DEVICES OR SYSTEMS WITHOUT THE EXPRESS WRITTEN APPROVAL OF FAIRCHILD SEMICONDUCTOR CORPORATION.

As used herein:

1. Life support devices or systems are devices or systems which, (a) are intended for surgical implant into the body or (b) support or sustain life, and (c) whose failure to perform when properly used in accordance with instructions for use provided in the labeling, can be reasonably expected to result in a significant injury of the user.
2. A critical component in any component of a life support, device, or system whose failure to perform can be reasonably expected to cause the failure of the life support device or system, or to affect its safety or effectiveness.

ANTI-COUNTERFEITING POLICY

Fairchild Semiconductor Corporation's Anti-Counterfeiting Policy. Fairchild's Anti-Counterfeiting Policy is also stated on our external website, www.fairchildsemi.com, under Sales Support.

Counterfeiting of semiconductor parts is a growing problem in the industry. All manufacturers of semiconductor products are experiencing counterfeiting of their parts. Customers who inadvertently purchase counterfeit parts experience many problems such as loss of brand reputation, substandard performance, failed applications, and increased cost of production and manufacturing delays. Fairchild is taking strong measures to protect ourselves and our customers from the proliferation of counterfeit parts. Fairchild strongly encourages customers to purchase Fairchild parts either directly from Fairchild or from Authorized Fairchild Distributors who are listed by country on our web page cited above. Products customers buy either from Fairchild directly or from Authorized Fairchild Distributors are genuine parts, have full traceability, meet Fairchild's quality standards for handling and storage and provide access to Fairchild's full range of up-to-date technical and product information. Fairchild and our Authorized Distributors will stand behind all warranties and will appropriately address any warranty issues that may arise. Fairchild will not provide any warranty coverage or other assistance for parts bought from Unauthorized Sources. Fairchild is committed to combat this global problem and encourage our customers to do their part in stopping this practice by buying direct or from authorized distributors.

PRODUCT STATUS DEFINITIONS

Definition of Terms

Datasheet Identification	Product Status	Definition
Advance Information	Formative / In Design	Datasheet contains the design specifications for product development. Specifications may change in any manner without notice.
Preliminary	First Production	Datasheet contains preliminary data; supplementary data will be published at a later date. Fairchild Semiconductor reserves the right to make changes at any time without notice to improve design.
No Identification Needed	Full Production	Datasheet contains final specifications. Fairchild Semiconductor reserves the right to make changes at any time without notice to improve the design.
Obsolete	Not In Production	Datasheet contains specifications on a product that is discontinued by Fairchild Semiconductor. The datasheet is for reference information only.

Rev. 140