

SHINDENGEN

General Purpose Rectifiers

DIL Bridges

S1NB20

200V 1A

FEATURES

- Small Dual In-Line (:DIL) Package
- 5 mm pitch between terminals
- Applicable to Automatic Insertion

APPLICATION

- Switching power supply
- Home Appliances, Office Equipment
- Telecommunication, Factory Automation

OUTLINE DIMENSIONS

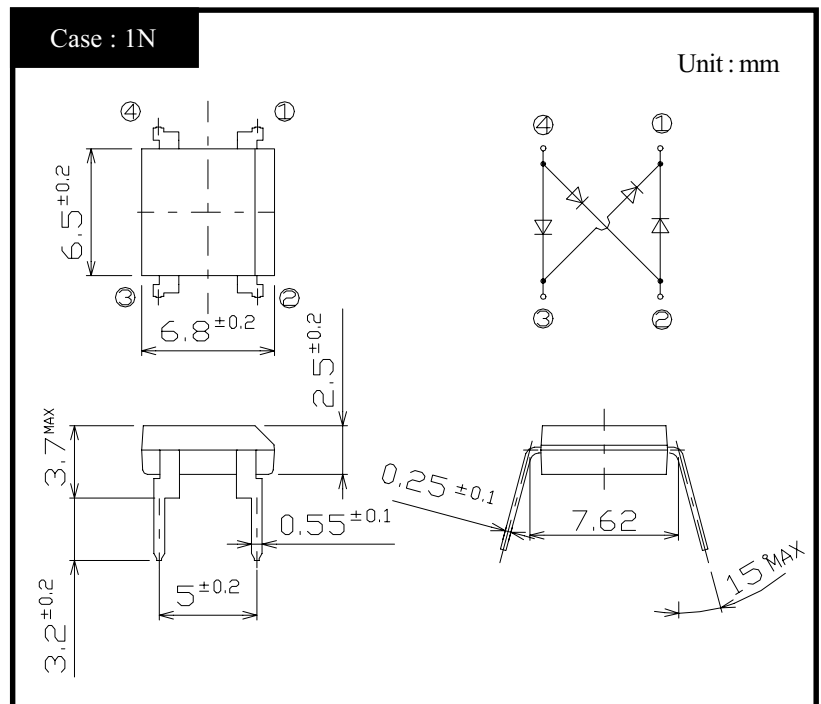

RATINGS

● Absolute Maximum Ratings (If not specified $T_I=25^\circ\text{C}$)

Item	Symbol	Conditions	Ratings	Unit
Storage Temperature	T_{stg}		-40~150	$^\circ\text{C}$
Operating Junction Temperature	T_j		150	$^\circ\text{C}$
Maximum Reverse Voltage	V_{RM}		200	V
Average Rectified Forward Current	I_O	50Hz sine wave, R-load, On glass-epoxy substrate, $T_a=25^\circ\text{C}$	1	A
Peak Surge Forward Current	I_{FSM}	50Hz sine wave, Non-repetitive 1 cycle peak value, $T_j=25^\circ\text{C}$	30	A
Current Squared Time	I^2t	$1\text{ms} \leq t < 10\text{ms}$, $T_j=25^\circ\text{C}$	4.5	A^2s

● Electrical Characteristics (If not specified $T_I=25^\circ\text{C}$)

Item	Symbol	Conditions	Ratings	Unit
Forward Voltage	V_F	$I_F=0.5\text{A}$, Pulse measurement, Rating of per diode	Max.1.05	V
Reverse Current	I_R	$V_R=V_{RM}$, Pulse measurement, Rating of per diode	Max.10	μA
Thermal Resistance	θ_{jl}	junction to lead	Max.15	$^\circ\text{C}/\text{W}$
	θ_{ja}	junction to ambient	Max.68	

S1NBx

Forward Voltage

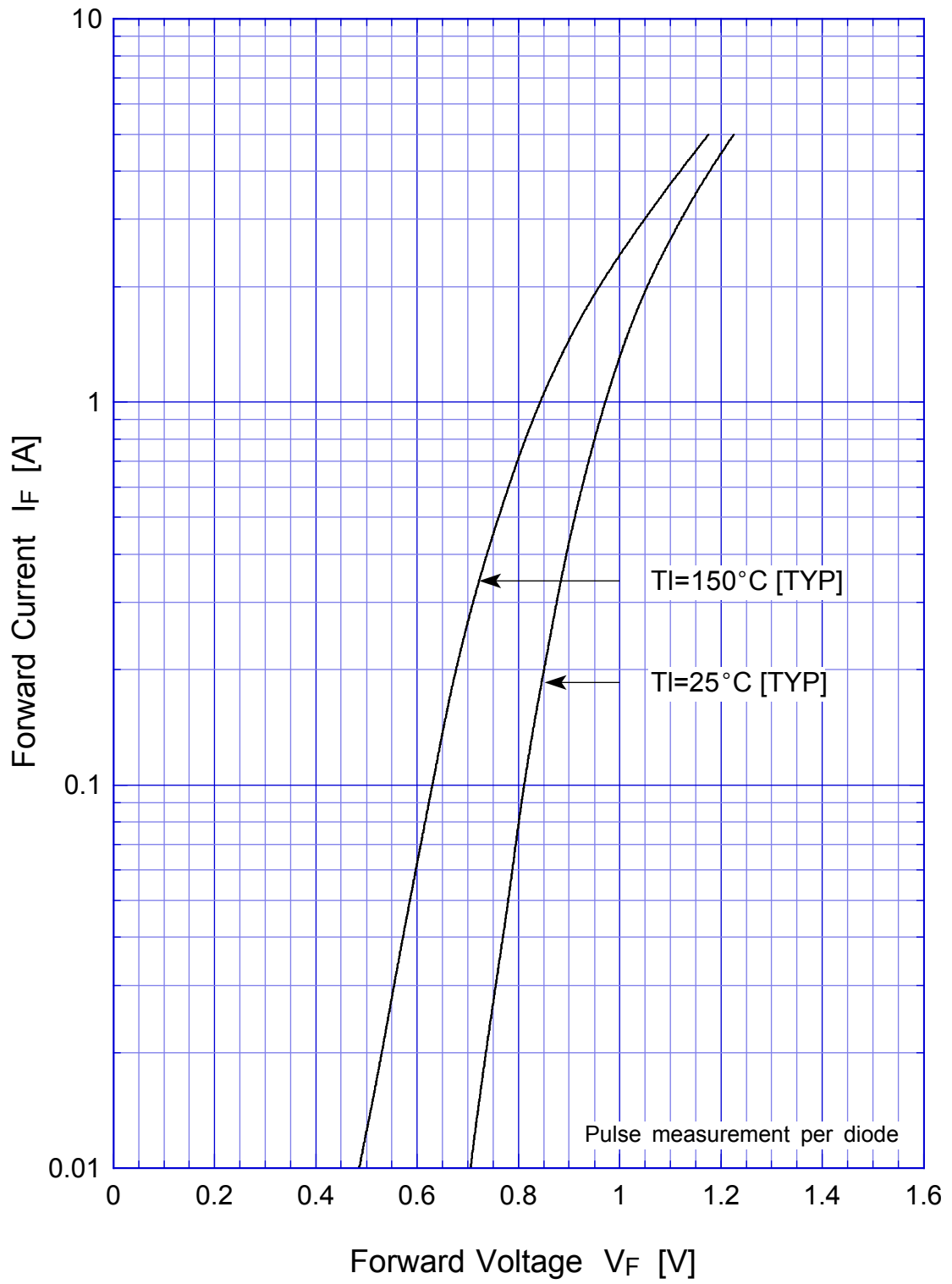

S1NBx

Forward Power Dissipation

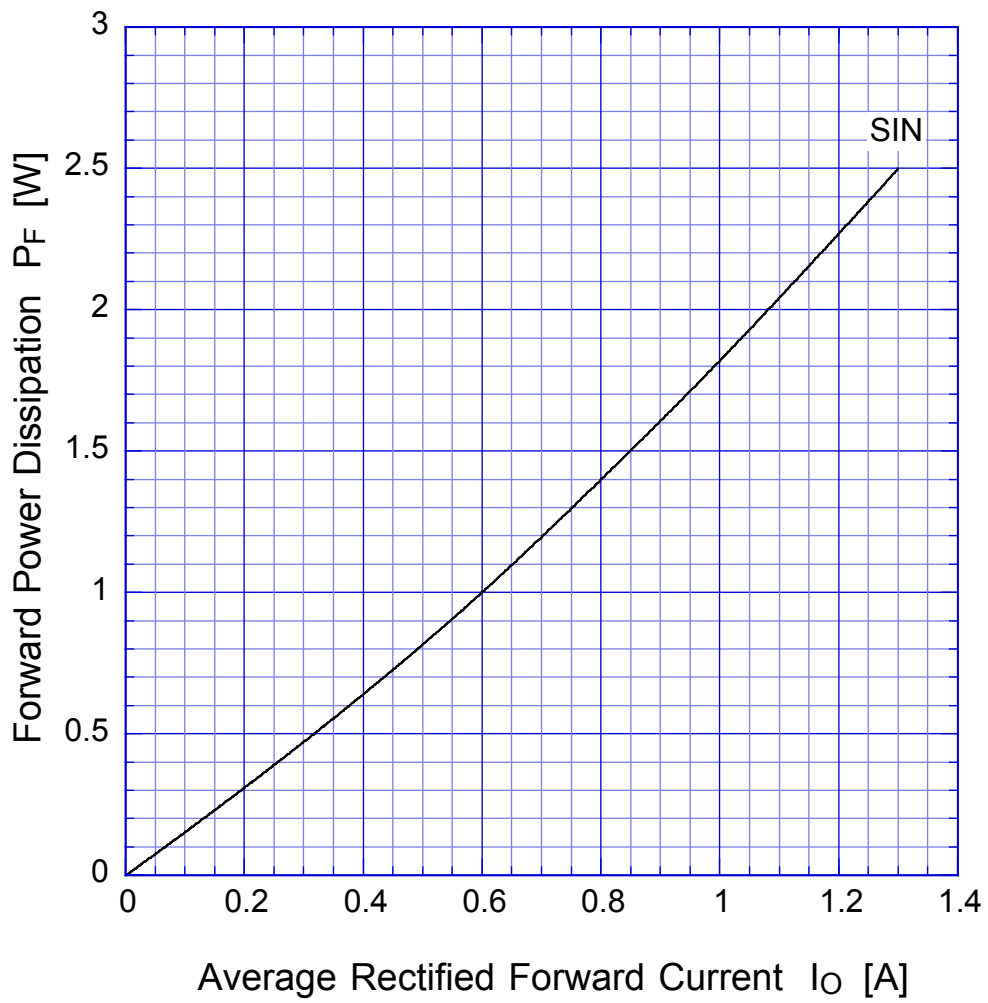

$T_j = 150^\circ\text{C}$
Sine wave

S1NBx

Derating Curve

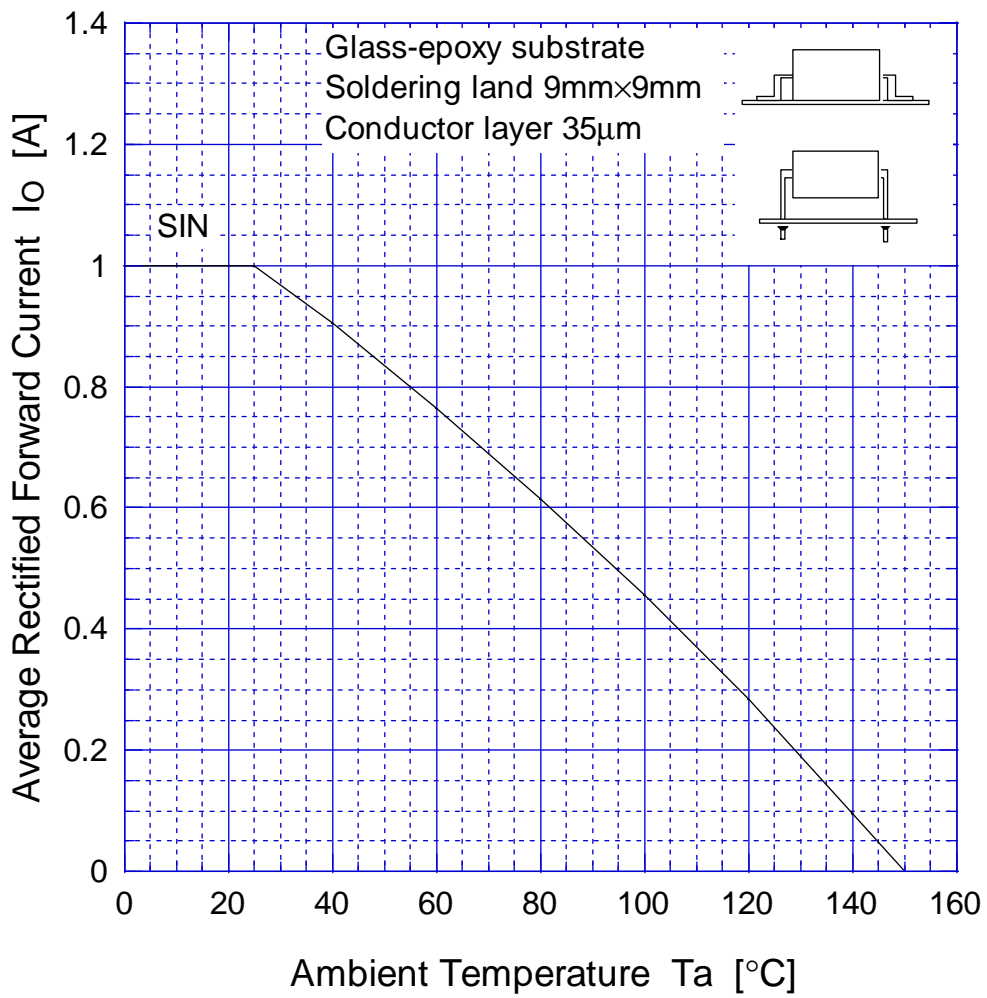

Sine wave
R-load
Free in air

S1NBx

Peak Surge Forward Capability

