

SD

879-4-15 MA9

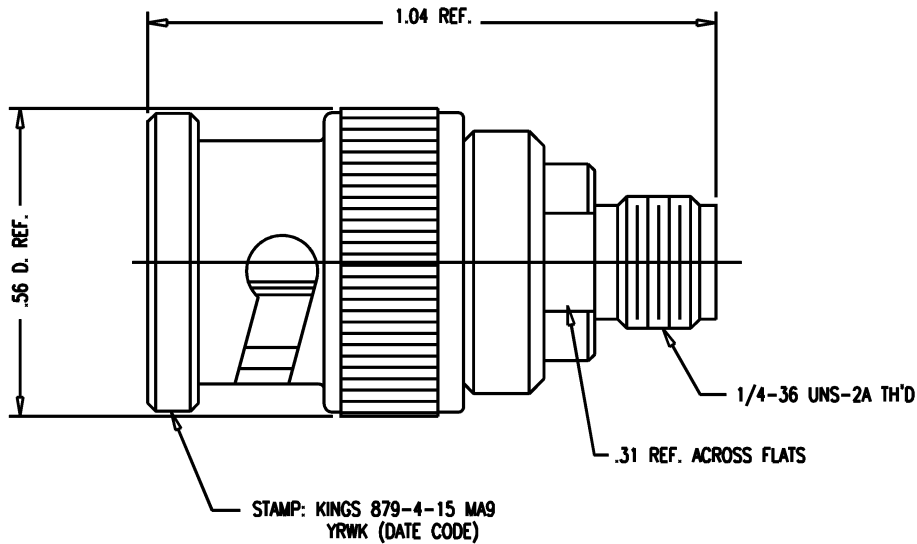

NOTES:

- MARK PACKAGE: KINGS 879-4-15 MA9
YRWK (DATE CODE)
- MATERIALS:
INSULATOR-TEFLON, L-P-403
GASKET-SILICONE RUBBER, ZZ-R-765
CENTER CONTACT }
OUTER CONTACT } BERYLLIUM COPPER, ASTM-B-196
SMA BODY }
SPRING WASHER }
ALL OTHER METAL PARTS-BRASS, ASTM-B16
- FINISHES:
CENTER CONTACT: HARD GOLD PLT., .0001 MIL-G-45204
SPRING WASHER: SILVER PLATE PER QQ-S-365
ALL OTHER METAL PARTS-HARD GOLD PLT., .00005 MIN. MIL-G-45204
- ELECTRICAL CHARACTERISTICS:
NOMINAL IMPEDANCE-50 OHMS
FREQUENCY RANGE-DC TO 4 GHZ
DIELECTRIC WITHSTANDING VOLTAGE-1000 VOLTS RMS 60 HZ
AT SEA LEVEL

REVISIONS

ISSUE	CHANGES
0	ER 9199 PW 01/13/71
1	FORMAT CN 10400 C CC 11/11/71
2	CN 18981 A MJB 12/28/78
3	CN 37594 C REDRAWN TML 02/22/00

879415S

SCALE 4:1

APPROX SURFACE AREA

USED ON

REF:

ADPT, BNC TO SMA, M-F

DRAWN CC DATE 12/01/70

DESIGN DATE

APPR. PW DATE 01/13/71

KINGS
ELECTRONICS CO., INC.
ROCK HILL, SOUTH CAROLINA 29730

879-4-15 MA9

SD