

## Standard Recovery Diodes, 160 A (INT-A-PAK Power Modules)

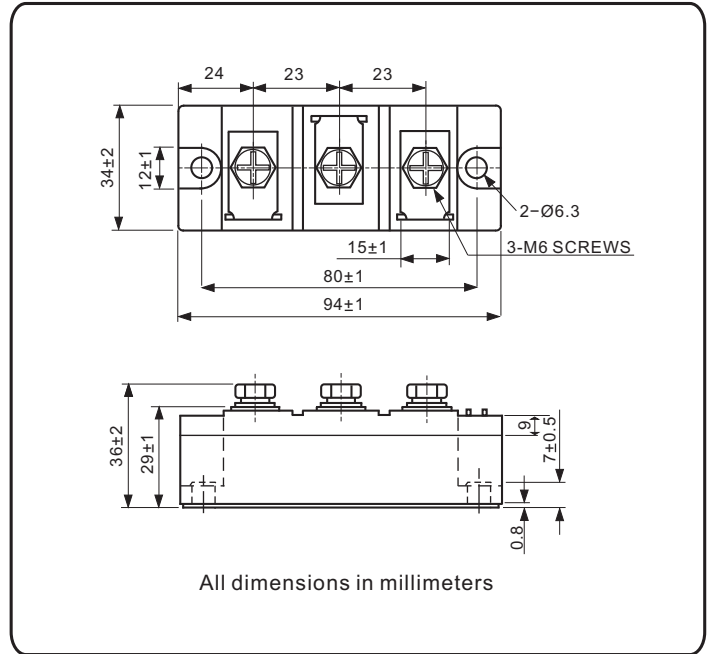

### FEATURES

- High voltage
- Electrically isolated by DBC ceramic ( $Al_2O_3$ )
- 3000  $V_{RMS}$  isolating voltage
- Industrial standard package
- High surge capability
- Glass passivated chips
- Modules uses high voltage power diodes in four basic configurations
- Simple mounting
- UL approved file E320098
- Compliant to RoHS
- Designed and qualified for multiple level



### APPLICATIONS

- DC motor control and drives
- Battery charges
- Welders
- Power converters

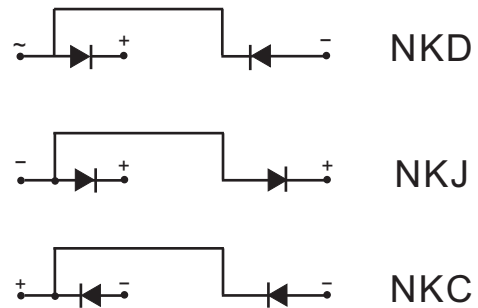

PRODUCT SUMMARY	
$I_{F(AV)}$	160 A
Type	Modules - Diode, High Voltage

MAJOR RATINGS AND CHARACTERISTICS			
SYMBOL	CHARACTERISTICS	VALUE	UNITS
$I_{F(AV)}$		160	A
	$T_C$	100	$^{\circ}C$
$I_{F(RMS)}$		251	A
$I_{FSM}$	50 Hz	3870	
	60 Hz	4072	
$I^2t$	50 Hz	75	$kA^2s$
	60 Hz	68	
$I^2\sqrt{t}$		748	$kA^2\sqrt{s}$
$V_{RRM}$		400 to 1600	V
$T_J$	Range	-40 to 150	$^{\circ}C$

### ELECTRICAL SPECIFICATIONS

VOLTAGE RATINGS				
TYPE NUMBER	VOLTAGE CODE	$V_{RRM}$ , MAXIMUM REPETITIVE PEAK REVERSE VOLTAGE V	$V_{RSM}$ , MAXIMUM NON-REPETITIVE PEAK REVERSE VOLTAGE V	$I_{RRM}$ AT 150 °C mA
NKD160 NKJ160 NKC160	04	400	500	8
	08	800	900	
	12	1200	1300	
	14	1400	1500	
	16	1600	1700	

FORWARD CONDUCTION					
PARAMETER	SYMBOL	TEST CONDITIONS	VALUE	UNITS	
Maximum average on-state current at case temperature	$I_{F(AV)}$	180° conduction, half sine wave	160	A	
			100	°C	
Maximum RMS on-state current	$I_{F(RMS)}$	180° conduction, half sine wave ,50Hz , $T_C = 100^{\circ}C$	251	A	
Maximum peak, one-cycle, on-state non-repetitive surge current	$I_{FSM}$	No voltage reapplied	t = 10 ms		3870
			t = 8.3 ms	4072	
Maximum $I^2t$ for fusing	$I^2t$	100% $V_{RRM}$ reapplied	Sine half wave, initial $T_J = T_J$ maximum	t = 10 ms	75
				t = 8.3 ms	68
				t = 10 ms	52.5
				t = 8.3 ms	47.8
Maximum $I^2\sqrt{t}$ for fusing	$I^2\sqrt{t}$	t = 0.1 ms to 10 ms, no voltage reapplied	748	$kA^2\sqrt{s}$	
Maximum forward voltage drop	$V_{FM}$	$I_{FM} = 480A$ , $T_J = 25^{\circ}C$ , 180° conduction	1.3	V	

BLOCKING				
PARAMETER	SYMBOL	TEST CONDITIONS	VALUES	UNITS
Maximum peak reverse and off-state leakage current	$I_{RRM}$	$T_J = 150^{\circ}C$	10	mA
RMS isolation Voltage	$V_{ISO}$	50 Hz, circuit to base ,all terminals shorted ,t = 1s	3000	V
		t = 60s	2500	

THERMAL AND MECHANICAL SPECIFICATIONS				
PARAMETER	SYMBOL	TEST CONDITIONS	VALUES	UNITS
Maximum junction operating temperature range	$T_{Stg}$ , $T_J$		- 40 to 150	°C
Maximum thermal resistance, junction to case per junction	$R_{thJC}$	DC operation	0.35	°C/W
Maximum thermal resistance, case to heatsink per module	$R_{thCS}$	Mounting surface, smooth , flat and greased	0.09	
Mounting torque $\pm 10\%$	IAP to heatsink, M6 busbar to IAP, M6	A mounting compound is recommended and the torque should be rechecked after a period of 3 hours to allow for the spread of the compound. Lubricated threads.	4 to 6	N.m
Approximate weight			220	g
			7.8	oz.
Case style			New INT-A-PAK	

Fig.1 On-state current vs. voltage characteristic

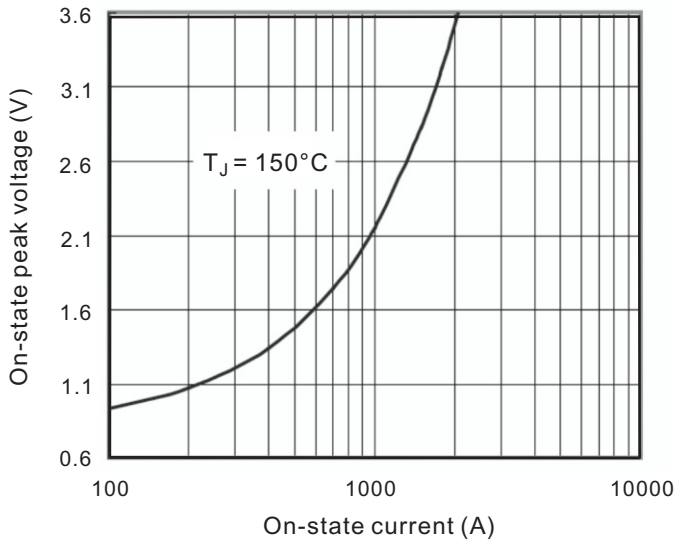

Fig.2 Transient thermal impedance(junction-case)

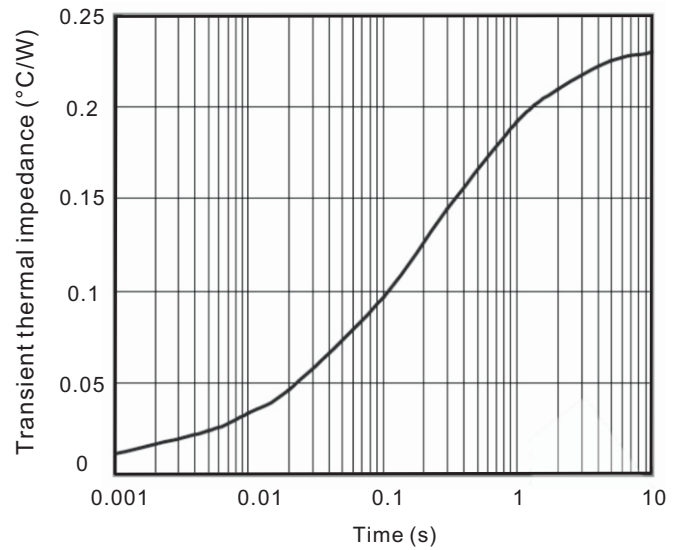

Fig.3 Power consumption vs. average current

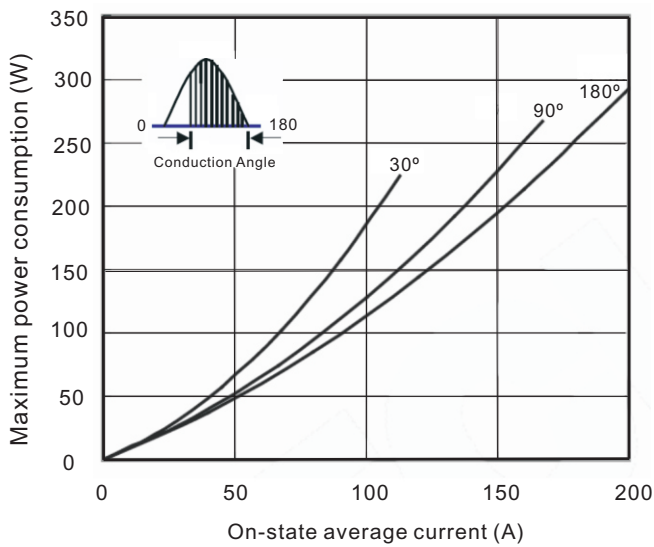

Fig.4 Case temperature vs. on-state average current

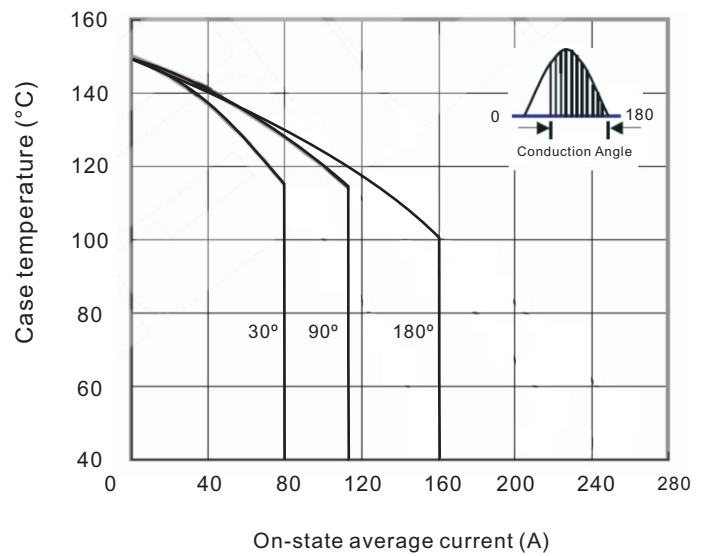

Fig.5 On-state surge current vs cycles

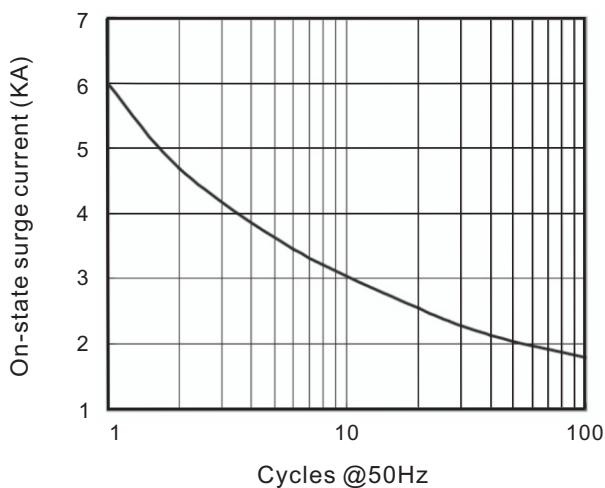

Fig.6  $I^2t$  Characteristic

