

NOTES: UNLESS OTHERWISE SPECIFIED

1. INTERFACE COMPLIANT TO SMPTE 304 SPECIFICATION.
2. MATERIAL SPECIFICATIONS:
 CONTACTS: COPPER ALLOY
 O-RINGS AND STRAIN RELIEF: SILICONE RUBBER
 ALL PLASTIC PARTS: 20% GLASS FILLED POLYPROPYLENE
 ALL OTHER METAL PARTS: 303 STAINLESS STEEL PER ASTM A582
3. FINISH SPECIFICATIONS:
 STAINLESS STEEL PARTS: PASSIVATE
 CONTACTS: .000100 MIN GOLD PER ASTM B488 OVER
 .000080 MIN NICKEL PER AMS-QQN-290 (RoHS)
4. ELECTRICAL SPECIFICATIONS:
 LOW VOLTAGE CONTACTS: 42 - 60 VAC, 1 AMP
 AUX ELECTRICAL CONTACTS: 600 VAC, 10 AMP
5. ENVIRONMENTAL:
 OPERATING TEMPERATURE RATING: -40°C TO 75°C
 NON-OPERATING/STORAGE TEMPERATURE RATING: -40°C TO 85°C
 HUMIDITY: <95 RH (AT 40°C)
6. OPTICAL:
 WAVELENGTH: 1250nm - 1625nm
 INSERTION LOSS: 0.3dB TYPICAL, 0.5dB MAX
 RETURN LOSS: > -45dB, -50dB TYPICAL
7. REPLACEMENT KITS:
 CONTACT KIT: 7760-000-00702Z
8. CABLE PREPARATION AND STRIPPING PROCEDURE: CAP-TBD.
9. RED LDPE DUST CAP INCLUDED (NOT SHOWN)
10. CRIMP TOOLING:
 FOR FACTORY APPLICATION USE HAND TOOL KTH-1000 AND DIE KTH-2035
 FOR FIELD APPLICATION USE HAND TOOL KTH-5000 AND DIE KTH-5018
11. ELECTRICAL AND OPTICAL CONTACTS INCLUDED

REV	DESCRIPTION	BY DATE	APPD
01	PRELIMINARY PER ER 30232	DRK 01/26/11	XXX

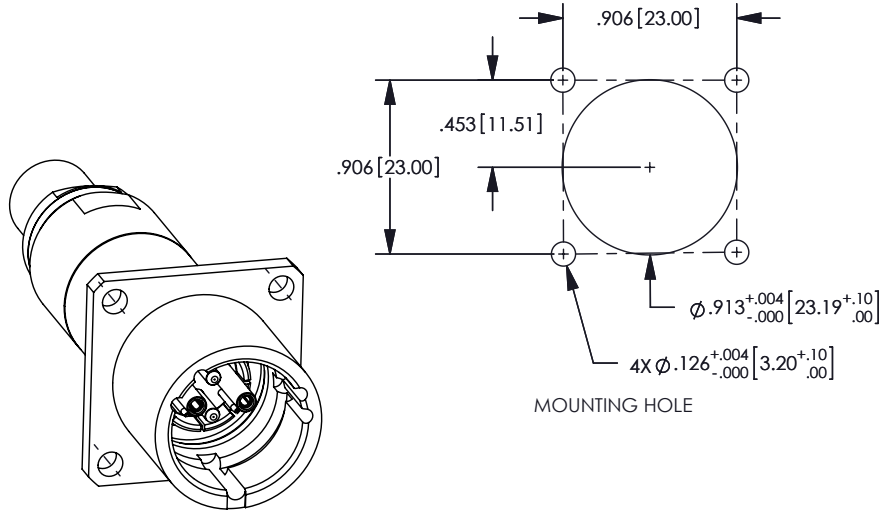
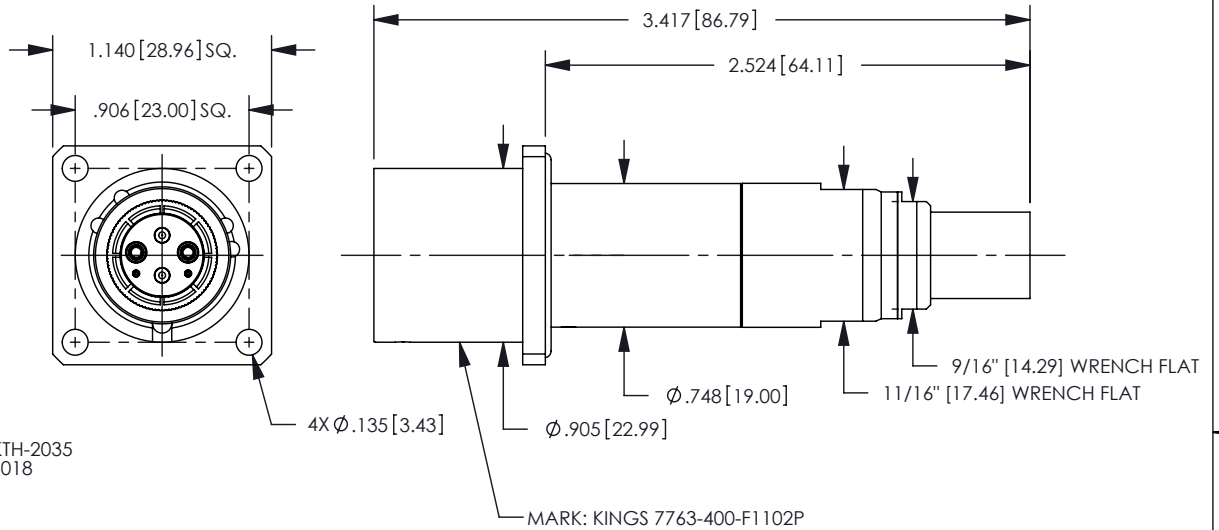

CATALOG P/N:7763-400-F1 102P

PER ASME Y14.5M-1994 UNLESS OTHERWISE SPECIFIED: DIMENSIONS ARE IN INCHES [MM] TOLERANCES: DECIMAL: XX [X.X] ± .01 [0.3] .XXX [X.XX] ± .005 [0.13] .XXXX [X.XXX] ± .XXXX ANGLES: ± 2° SCALE: 1:1				by WINCHESTER Winchester Electronics Corporation 62 Barnes Industrial Road North Wallingford, Connecticut 06492	
CUSTOMER SALES DRAWING			THIRD ANGLE		
TRI LOCK SMPTE PANEL MOUNT 4 HOLE, JACK, CABLE					
DRAWN	DATE	APPROVED	DATE	SHT	OF
DRK	01/26/11	PSM	02/01/11	1	1
APPROVED	DATE	APPROVED	DATE	REV	
JCF	02/01/11	XXX	XX/XX/XX	01	