

M28840/3 Strain Relief



Strain
Reliefs

Glenair Connector
Designator G

MIL-C-28840

M28840/3 J W

Basic Part No.

Designator

Material and Finish Designator

W = Aluminum, Cadmium Olive

Drab over Electroless Nickel

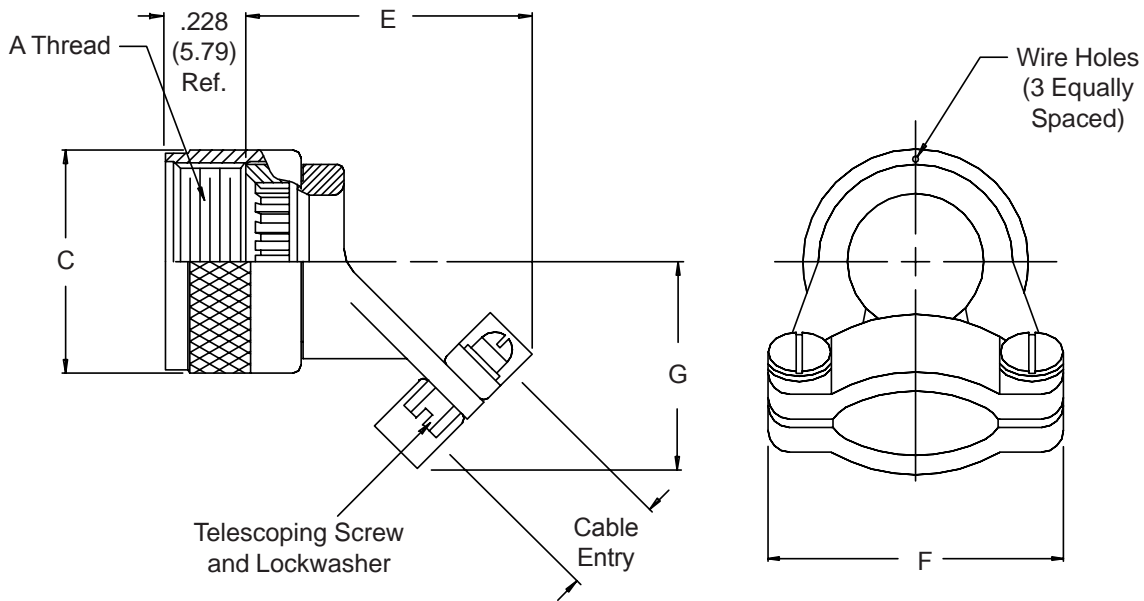

TABLE I

Shell Designator	Size Ref.	A Thread Class 2B	C Max	E Max	F Max	G Max	Cable Entry	
							Min	Max
A	11	.750 - 20 UNEF	1.028 (26.1)	1.650 (41.9)	.903 (22.9)	.929 (23.6)	.177 (4.5)	.286 (7.3)
B	13	.875 - 20 UNEF	1.141 (29.0)	1.650 (41.9)	.977 (24.8)	.929 (23.6)	.177 (4.5)	.286 (7.3)
C	15	1.000 - 20 UNEF	1.263 (32.1)	1.765 (44.8)	1.151 (29.2)	1.056 (26.8)	.250 (6.4)	.416 (10.6)
D	17	1.125 - 18 UNEF	1.387 (35.2)	1.874 (47.6)	1.281 (32.5)	1.233 (31.3)	.291 (7.4)	.476 (12.1)
E	19	1.250 - 18 UNEF	1.513 (38.4)	1.918 (48.7)	1.406 (35.7)	1.296 (32.9)	.348 (8.8)	.626 (15.9)
F	23	1.438 - 18 UNEF	1.703 (43.3)	1.962 (49.8)	1.576 (40.0)	1.358 (34.5)	.429 (10.9)	.831 (21.1)
G	25	1.562 - 18 UNEF	1.825 (46.4)	2.006 (51.0)	1.666 (42.3)	1.420 (36.1)	.523 (13.3)	.956 (24.3)
H	29	1.875 - 16 UN	2.143 (54.4)	2.301 (58.4)	2.046 (52.0)	1.634 (41.5)	.643 (16.3)	1.081 (27.5)
J	33	2.062 - 16 UNS	2.329 (59.2)	2.389 (60.7)	2.209 (56.1)	1.859 (47.2)	.704 (17.9)	1.187 (30.1)

1. For complete dimensions see applicable Military Specification.
2. Metric dimensions (mm) are indicated in parentheses.
3. Cable Entry is defined as the accomodation entry for the wire bundle or cable. Dimensions are not intended for inspection criteria.