

REVISIONS			
LTR	DESCRIPTION	DATE	APPROVED
H2	REVISED PER ECO-12-013906	7/29/12	K. YEE

If this document is printed it becomes uncontrolled. Check for the latest revision

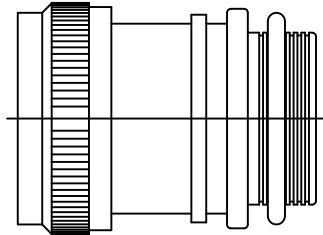

### CODE 40 TINEL-LOCK ADAPTER

NOTES:

1. THIS PRODUCT IS DESIGNED TO TERMINATE A BRAIDED CABLE SHIELD AND A HEAT SHRINKABLE LIPPED BOOT TO A CONNECTOR.
2. SEE CH00-0250-008 FOR ORDERING INFORMATION, MODIFICATIONS AND ADDITIONAL DIMENSIONS.
- ③ SEE DRAWING "TR" FOR DETAILS ON TINEL-LOCK RING. RINGS ARE DESIGNED TO BE HEATED ELECTRICALLY. ALL RINGS ARE MARKED WITH THERMOCHROMIC PAINT WHICH CHANGES COLOR WHEN INSTALLATION TEMPERATURE IS REACHED.
4. ADAPTER TO BE PERMANENTLY MARKED WITH CODE IDENT. NO. AND PART NO. LESS RING DESIGNATOR (E.G.: 06090-TXR40AB00-1206). RINGS SHALL BEAR NO MARKING.
- ⑤ FOR LARGER ENTRY SIZES, A 2 PIECE ADAPTER (TYPE II) IS SUPPLIED.
- ⑥ ADAPTER MATES TO MIL-C-38999, SERIES III AND IV, CLASS C, F, K, AND W, D38999/20, /24, /26, /40, /46, /47 CONNECTORS, AND WHEN SO MATED SHALL PROVIDE A WATER-TIGHT SEAL MEETING THE REQUIREMENTS OF MIL-C-85049, PAR. 3.5.7.
- ⑦ THESE DIMENSIONS APPLY IF A SELF-LOCKING COUPLING NUT IS USED. (MOD. CODE "S").

©2012 Tyco Electronics Corporation. All rights reserved.

Raychem Adapters  
**CUSTOMER DRAWING**

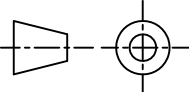
UNLESS OTHERWISE SPECIFIED DIMENSIONS ARE IN INCHES. METRIC DIMENSIONS ARE IN BRACKETS.	DRAWN R. RAMIREZ	DATE 03-18-93		TITLE TINEL-LOCK™ ADAPTER		
	CHECKED	DATE				
TYCO ELECTRONICS RESERVES THE RIGHT TO AMEND THIS DRAWING AT ANY TIME. USERS SHOULD EVALUATE THE SUITABILITY OF THE PRODUCT FOR THEIR APPLICATION	APPROVED W. C. GAY	DATE 05-19-93	SIZE   CODE IDENT. NO.   DWG. NO.   REV A   06090   TXR40   H2			
	APPROVED	DATE				
DECIMAL TOLERANCES .XXX ± 0.005 [0.13 mm] .XX ± 0.01 [0.25 mm] .X ± 0.1 [0.50 mm]	THIRD ANGLE PROJECTION 		DO NOT SCALE THIS DWG			
ANGLE TOLERANCE .X ± 1 DEG.			SHEET 1 OF 3			

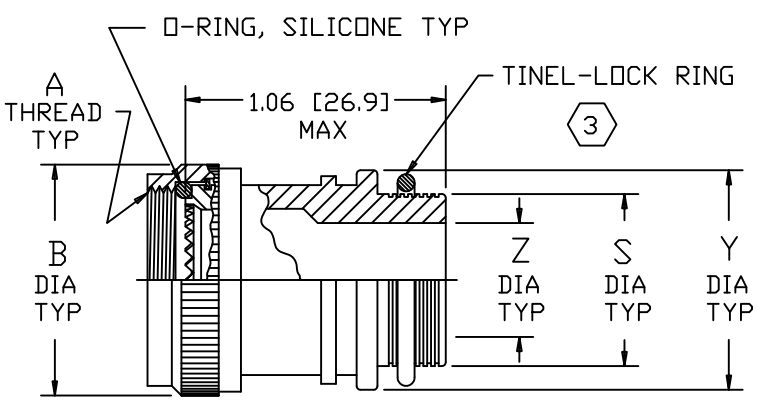

STRAIGHT ADAPTER-TYPE I

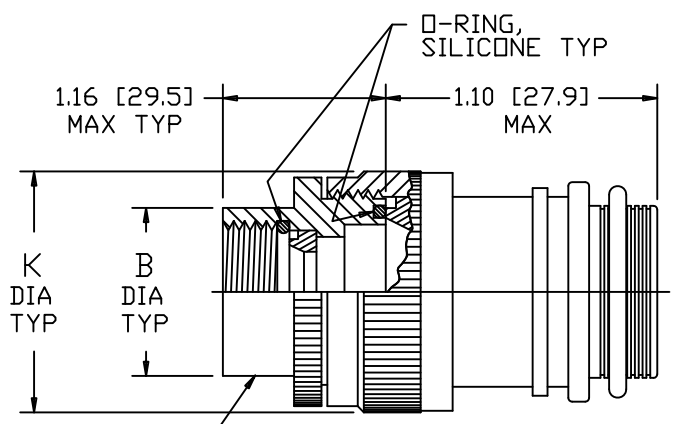

STRAIGHT ADAPTER-TYPE II

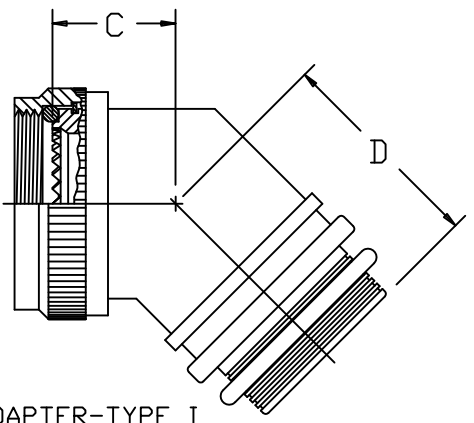

45° ADAPTER-TYPE I

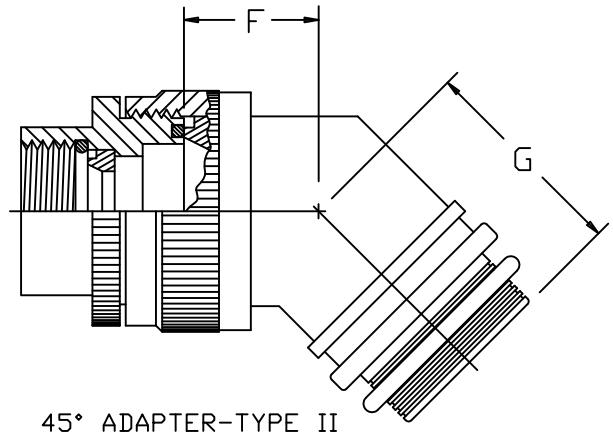

45° ADAPTER-TYPE II

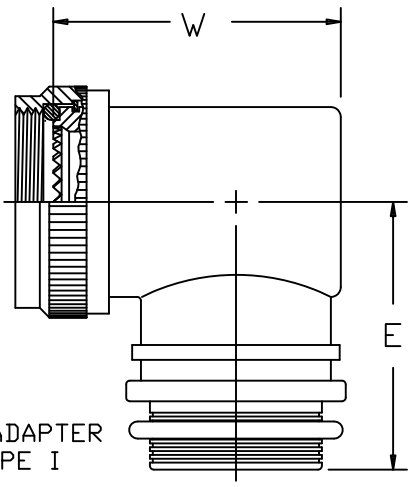

90° ADAPTER TYPE I

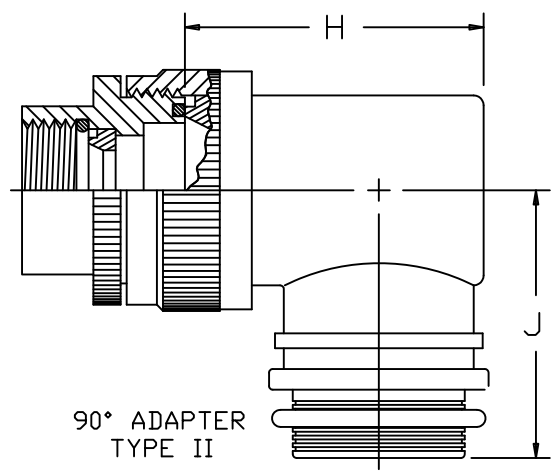

90° ADAPTER TYPE II

Raychem Adapters  
CUSTOMER DRAWING

SIZE	CODE IDENT. NO.	DWG. NO.	REV
A	06090	TXR40	H2
DO NOT SCALE THIS DWG		CAD NAME \ACAD12\TXR40-2	SHEET 2 OF 3



TABLE I									
ORDER NO.	SHELL SIZE 		MAX ENTRY SIZE  TYPE I	A METRIC THD CLASS 6H	B DIA MAX	B DIA MAX 	C MAX	D MAX	E MAX
	COM'L	MIL							
08	9	A	04	M12 X 1.0	.750 [19.1]	.969 [24.6]	.82 [20.8]	.89 [22.6]	1.10 [27.9]
10	11	B	07	M15 X 1.0	.850 [21.6]	1.063 [27.0]	.84 [21.3]	.92 [23.4]	1.20 [30.5]
12	13	C	08	M18 X 1.0	1.000 [25.4]	1.219 [31.0]	.87 [22.1]	.95 [24.1]	1.26 [32.0]
14	15	D	10	M22 X 1.0	1.150 [29.2]	1.406 [35.7]	.89 [22.6]	.95 [24.1]	1.34 [34.0]
16	17	E	12	M25 X 1.0	1.250 [31.8]	1.469 [37.3]	.92 [23.4]	.98 [24.9]	1.40 [35.6]
18	19	F	14	M28 X 1.0	1.400 [35.6]	1.594 [40.5]	.95 [24.1]	1.01 [25.7]	1.45 [36.8]
20	21	G	16	M31 X 1.0	1.500 [38.1]	1.750 [44.5]	.97 [24.6]	1.04 [26.4]	1.51 [38.4]
22	23	H	18	M34 X 1.0	1.650 [41.9]	1.844 [46.8]	1.00 [25.4]	1.07 [27.2]	1.57 [39.9]
24	25	J	20	M37 X 1.0	1.750 [44.5]	2.031 [51.6]	1.02 [25.9]	1.07 [27.2]	1.67 [42.4]

TABLE II									
ENTRY SIZE	Z +.010 -.020	S DIA	Y ±.015 [±0.38]	W MAX	F MAX	G MAX	H MAX	J MAX	K MAX
04	.250 [6.35]	.376 [9.56] .370 [9.39]	.550 [13.97]	1.23 [31.2]	N/A	N/A	N/A	N/A	N/A
05	.312 [7.92]	.438 [11.13] .432 [10.97]	.612 [15.54]	1.29 [32.8]	.77 [19.6]	.93 [23.6]	1.19 [30.2]	1.16 [29.5]	.80 [20.3]
06	.375 [9.52]	.501 [12.73] .495 [12.57]	.675 [17.14]	1.35 [34.3]	.77 [19.6]	.93 [23.6]	1.19 [30.2]	1.16 [29.5]	.80 [20.3]
07	.437 [11.09]	.563 [14.31] .556 [14.12]	.737 [18.71]	1.42 [36.1]	.80 [20.3]	.95 [24.1]	1.38 [35.1]	1.22 [31.0]	.92 [23.4]
08	.500 [12.70]	.626 [15.91] .619 [15.72]	.800 [20.32]	1.48 [37.6]	.80 [20.3]	.95 [24.1]	1.38 [35.1]	1.22 [31.0]	.92 [23.4]
10	.625 [15.87]	.752 [19.11] .742 [18.84]	.925 [23.49]	1.60 [40.6]	.84 [21.3]	1.00 [25.4]	1.51 [38.4]	1.35 [34.3]	1.18 [30.0]
12	.750 [19.05]	.877 [22.28] .867 [22.02]	1.050 [26.67]	1.73 [43.9]	.86 [21.8]	1.01 [25.7]	1.63 [41.4]	1.40 [35.6]	1.35 [34.3]
14	.875 [22.23]	1.002 [25.46] .991 [25.17]	1.175 [29.84]	1.85 [47.0]	.88 [22.4]	1.04 [26.4]	1.78 [45.2]	1.46 [37.1]	1.41 [35.8]
16	1.000 [25.40]	1.127 [28.63] 1.116 [28.34]	1.300 [33.02]	2.00 [50.8]	.91 [23.1]	1.06 [26.9]	1.88 [47.8]	1.53 [38.9]	1.60 [40.6]
18	1.125 [28.57]	1.252 [31.81] 1.241 [31.52]	1.425 [36.19]	2.13 [54.1]	.93 [23.6]	1.09 [27.7]	2.01 [51.1]	1.59 [40.4]	1.66 [42.2]
20	1.250 [31.75]	1.377 [34.98] 1.366 [34.69]	1.550 [39.37]	2.25 [57.2]	.98 [24.9]	1.13 [28.7]	2.13 [54.1]	1.78 [45.2]	2.04 [51.8]
22	1.375 [34.93]	1.502 [38.15] 1.488 [37.79]	1.675 [42.55]	N/A	1.03 [26.2]	1.38 [35.1]	2.29 [58.2]	1.85 [47.0]	2.23 [56.6]
24	1.500 [38.10]	1.627 [41.33] 1.613 [40.97]	1.800 [45.72]	N/A	1.08 [27.4]	1.44 [36.6]	2.42 [61.5]	1.92 [48.8]	2.23 [56.6]

Raychem Adapters  
CUSTOMER DRAWING

SIZE	CODE IDENT. NO.	DWG. NO.	REV
A	06090	TXR40	H2
DO NOT SCALE THIS DWG		CAD NAME \ACAD\TXR40-3	SHEET 3 OF 3