

No. OF PINS	DIMENSIONS							
	A	B	C	D	E	F	G	H
9	1.213	0.984	0.666	0.329	0.236	0.756	0.496	0.427
	30.80	24.99	16.92	8.36	5.99	19.20	12.60	10.85
15	1.541	1.312	0.994	0.329	0.236	1.091	0.496	0.427
	39.15	33.32	25.25	8.36	5.99	27.70	12.60	10.85
25	2.087	1.852	1.534	0.329	0.236	1.618	0.496	0.427
	53.00	47.04	38.96	8.36	5.99	41.10	12.60	10.85

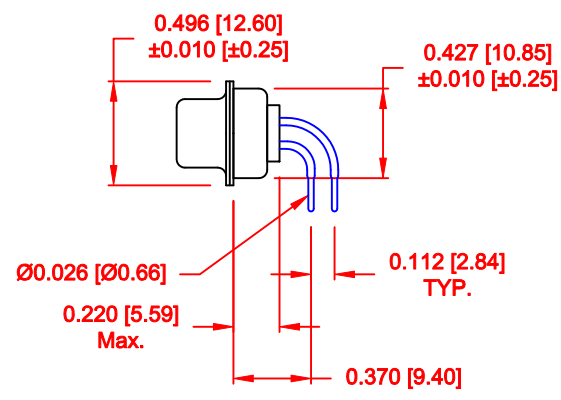
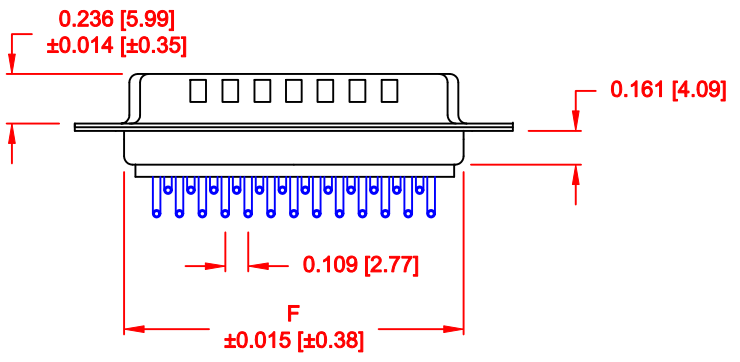
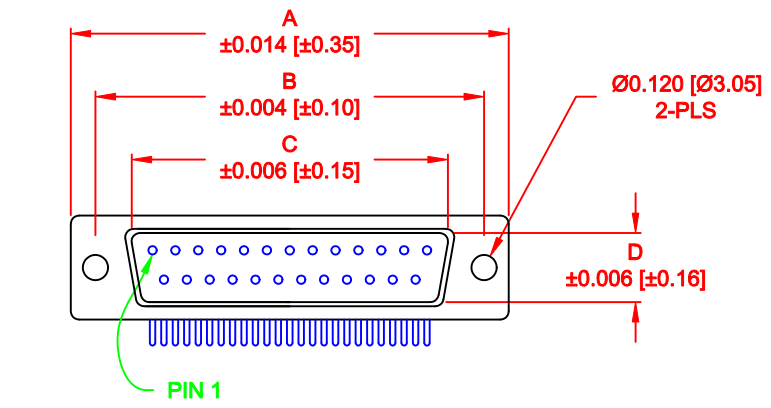

**774-EYY-1 1 3 R YY 1**

SERIES ————

POSITIONS ————

E09

E15

E25

GENDER ————

1 = MALE

TERMINATION ————

1 = THROUGH HOLE

SHELL PLATING ————

3 = NICKEL (GROUND INDENTS)

RoHS COMPLIANT ————

HARDWARE OPTIONS ————

00 = NO HARDWARE

01 = .065" CLINCH NUT (BOARD SIDE)

14 = SHORT BRACKET WITH 4-40 SCREW LOCK

PLATING OPTIONS ————

1 = GOLD FLASH

2 = 30 MICRO-INCH GOLD

**MEETS IP67 STANDARDS**  
(SEE PAGE 3 FOR SEALING DETAILS)

**MATERIAL:**  
SHELL: STEEL, NICKEL PLATED  
INSULATOR: UL 94V-O RATED, WHITE PA6T  
PROCESS TEMP.: 260° C  
CONTACT: BRASS  
SEALING MATERIAL: F08 FLEXIBLE ADHESIVE

**ELECTRICAL:**  
CURRENT RATING: 5 AMPS  
CONTACT RESISTANCE: 15 mOhms Max.  
INSULATION RESISTANCE: 1,000 MOhms min.  
VOLTAGE: 500VAC FOR 1 MINUTE  
TEMPERATURE: -50° C TO 100° C

**RoHS COMPLIANT**

**DO NOT SCALE FROM DRAWING**

	THESE DRAWINGS AND SPECIFICATIONS ARE THE PROPERTY OF NorComp AND SHALL NOT BE REPRODUCED, COPIED OR USED AS THE BASIS FOR THE MANUFACTURE OF SALE OF APPARATUS WITHOUT WRITTEN PERMISSION.		DRAWN: <b>C. SMITH</b>	DATE: <b>03-26-09</b>
			CHECKED:	DATE:
<b>NorComp</b>		SCALE: <b>1 : 1</b>	SHEET <b>1</b> OF <b>3</b>	REV <b>4</b>
		DWG NO. <b>774-EYY-113RYY1</b>		

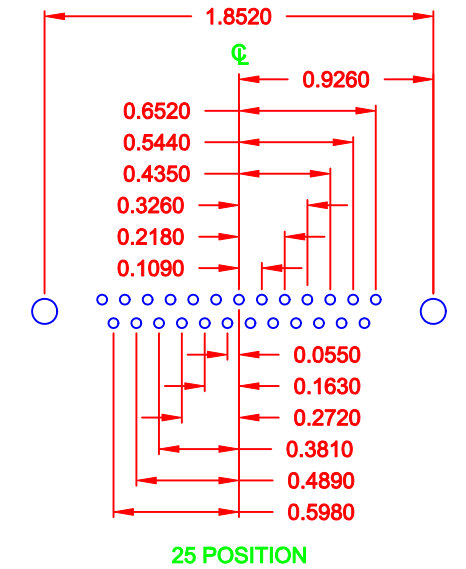
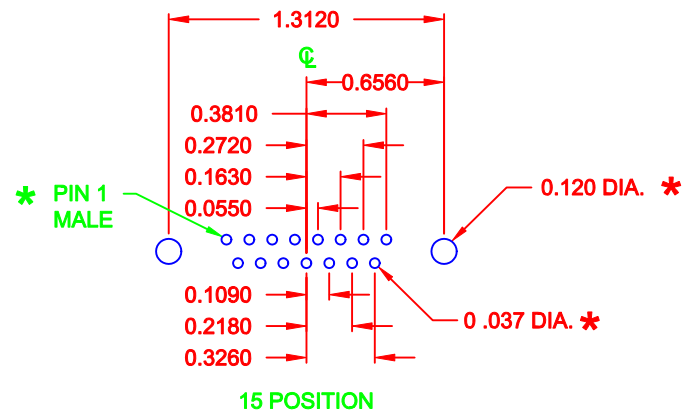
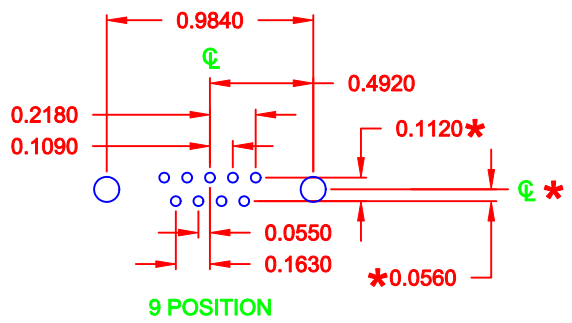

**\* TYP. ON ALL SIZES  
UNLESS NOTED OTHERWISE**

**DO NOT SCALE FROM DRAWING**

	THESE DRAWINGS AND SPECIFICATIONS ARE THE PROPERTY OF NorComp AND SHALL NOT BE REPRODUCED, COPIED OR USED AS THE BASIS FOR THE MANUFACTURE OF SALE OF APPARATUS WITHOUT WRITTEN PERMISSION.		DRAWN: <b>C. SMITH</b>	DATE: <b>06-10-09</b>
			CHECKED:	DATE:
NorComp		SCALE: <b>1 : 1</b>	SHEET <b>2</b> OF <b>3</b>	REV <b>4</b>
		DWG NO. <b>774-EYY-113RYY1</b>		

## HARDWARE OPTIONS

### 14 = SHORT BRACKET & 4-40 SCREW LOCK

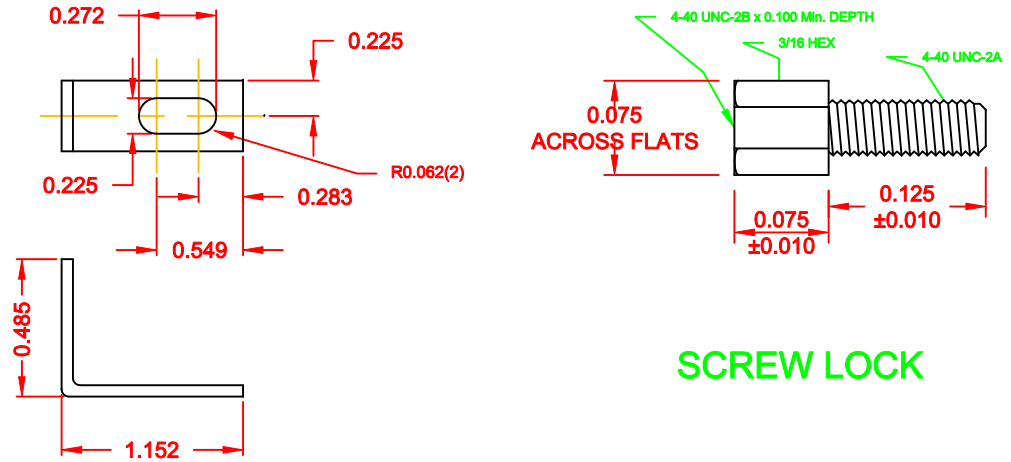

SCREW LOCK

MOUNTING BRACKET

### 01 CLINCH NUT OPTION

01X ..... 0.065" (BOARD SIDE) - CN1

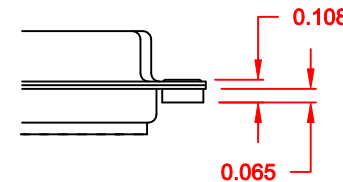

DO NOT SCALE FROM DRAWING

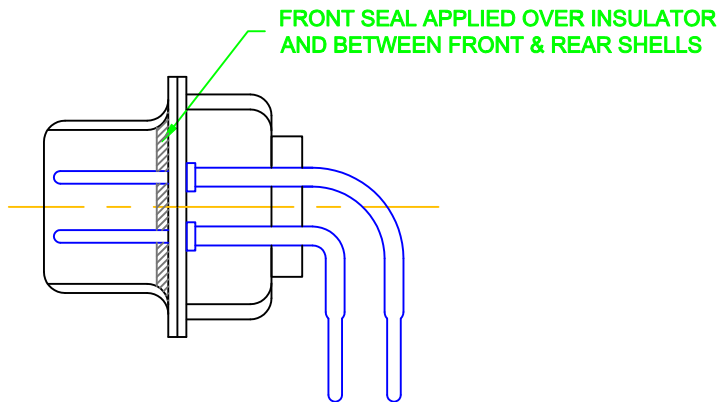
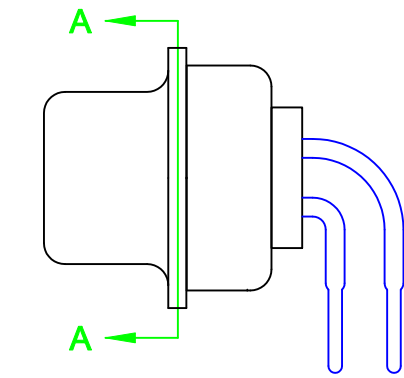

DETAIL A-A



THESE DRAWINGS AND SPECIFICATIONS ARE THE PROPERTY OF NorComp AND SHALL NOT BE REPRODUCED, COPIED OR USED AS THE BASIS FOR THE MANUFACTURE OF SALE OF APPARATUS WITHOUT WRITTEN PERMISSION.

DRAWN:  
**C. SMITH**

DATE:  
**06-10-09**

CHECKED:

DATE:

# NorComp

SCALE: **2.5 : 1** SHEET **3** OF **3** REV **4**

DWG NO. **774-EYY-113RYY1**