

DALLAS

SEMICONDUCTOR

DS1668, DS1669, DS1669S

Dallastat™ Electronic Digital Rheostat

FEATURES

- Replaces mechanical variable resistors
- Available as the DS1668 with manual interface or the DS1669 integrated circuit
- Human engineered interface provides easy control with DS1668
- Electronic interface provided for digital as well as manual control
- Wide differential input voltage range between 4.5 and 8 volts
- Wiper position is maintained in the absence of power
- Low cost alternative to mechanical controls
- Applications include volume, tone, contrast, brightness, and dimmer control
- 8-pin SOIC and 8-pin DIP packages for DS1669
- Standard resistance values for Dallastat
 - DS1668/DS1669-10 .. 10K Ω
 - DS1668/DS1669-50 .. 50K Ω
 - DS1668/DS1669-100 .. 100K Ω
- Operating Temperature Range
 - Commercial: 0°C to 70°C; DS1668, DS1669
 - Industrial: -40°C to +85°C; DS1669

PIN ASSIGNMENT DS1668

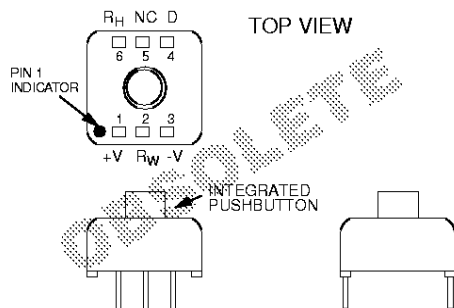

PIN ASSIGNMENT DS1669

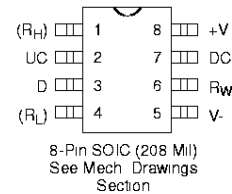
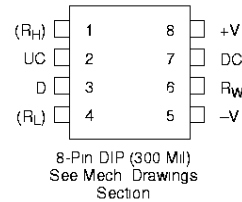

PIN DESCRIPTION DS1669

R_H	- Resistor High End
R_W	- Resistor Wiper
R_L	- Resistor Low End
-V, +V	- Voltage Inputs
UC	- Up Contact Input
D	- Digital Input
DC	- Down Contact Input

PIN DESCRIPTION DS1668

+V	- Positive Voltage Input
-V	- Negative Voltage
R_W	- Resistor Wiper
D	- Digital Input
R_H	- Resistor High End
NC	- No Connection - Pin Missing

DESCRIPTION

The DS1668 and DS1669 Dallastats are digital rheostats or potentiometers. These units provide 64 possible uniform tap points over the resistive range and are available in standard versions of 10K, 50K, and 100K ohms. The Dallastats can be controlled by either a mechanical-type contact closure input or a digital source input such as a CPU. Wiper position is maintained in the absence of power which is accomplished through the use of a EEPROM memory cell array. The EEPROM cell array is specified to accept greater than 80,000 writes.

The DS1668 and DS1669 differ in the type packages in which they are offered. The DS1668 is only available in a custom 6-pin package with a single integrated pushbutton as shown in the package drawing. The single integrated pushbutton provides the mechanical control input of the wiper position. In addition, a digital source input, D, allows the potentiometer to be controlled by a microcontroller or processor. Other package pins include the positive voltage input, +V, the negative voltage input, -V, the resistor wiper terminal, R_W , and the high resistor terminal, R_H . The DS1668 is rated for commercial temperature usage only (0°C to 70°C).

The DS1669 is offered in two standard IC packages which include an 8-pin 300 mil DIP and an 8-pin 200 mil SOIC. Like the DS1668, the DS1669 can be configured to operate using a single pushbutton or digital source input. This is illustrated in Figure 1. Additionally, the DS1669 can be configured to operate in a dual pushbutton configuration which is shown in Figure 2. The DS1669 pinouts allow access to both ends of the potentiometer R_L , R_H , and the wiper, R_W . Control inputs include the digital source input, D, the up contact input, UC, and the down contact input, DC. Other package pinouts include the positive, +V, and negative, -V, supply inputs. The DS1669 is available in commercial or industrial temperature versions.

OPERATION

The DS1668/DS1669 Dallastats are controlled through a contact closure input or by a digital source input. The DS1668 is configured to operate from a single contact closure (pushbutton) input which is integrated in the custom 6-pin package or the device can be driven from the digital source input (D). The DS1669 can be controlled using a single pushbutton input, dual pushbutton, or using the digital source input.

Figure 3 illustrates the single pushbutton configuration of the DS1668. Internally, the low end resistor terminal is connected to the negative supply input terminal. The integrated pushbutton has one side connected to the negative supply input while the other side is connected to the up contact terminal (UC). The digital source input (D) is accessible through pin 4 of the package. The (D) input has an internal pull-up resistor and can be allowed to float when not in use. The down contact input (DC) is not accessible externally. However, this control input is internally connected to the positive input supply.

When powered, the DS1668 assumes a single pushbutton mode of operation. Pressure applied to the integrated pushbutton will cause contact closure which in turn will move the wiper position upward or downward depending on the previous wiper direction. Single pushbutton mode is accomplished in the same manner for the DS1669. However, for the DS1669, all connections must be made by the user since no internal connections exist (see Figure 1). Note that single pushbutton control is accomplished when 1) the (DC) input is connected to the positive supply input and 2) the (D) input is allowed to float. These two conditions must exist from the time of device power-up. The UC input controls both upward and downward movement of the device wiper position in single pushbutton mode of operation.

Dual pushbutton operation is only available when using the DS1669. The DS1668, by design, only supports the single pushbutton mode of operation and digital source input control. Figure 2 provides a typical application example of the dual pushbutton configuration for the DS1669. In dual-pushbutton mode, the up-contact input (UC) is used solely to provide upward movement of the wiper position and the down-contact input (DC) is used to provide downward movement of the wiper position. For dual pushbutton configuration, all control inputs (UC, DC, and D) must remain open on device power-up.

The digital source input, D, was designed for microprocessor or controller applications. This control input manipulates the device in the same manner as the single pushbutton configuration; controlling movement of the wiper position in both upward and downward directions. One added feature over the single pushbutton configuration is the ability to increment or decrement wiper position at a faster rate. Digital source input control is available regardless of the type of pushbutton configuration.

DS1669 SINGLE PUSHBUTTON CONFIGURATION (TYPICAL EXAMPLE) Figure 1

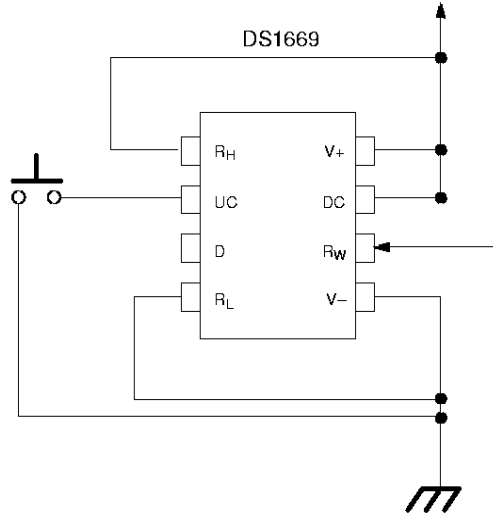

DS1669 DUAL PUSHBUTTON CONFIGURATION (TYPICAL APPLICATION) Figure 2

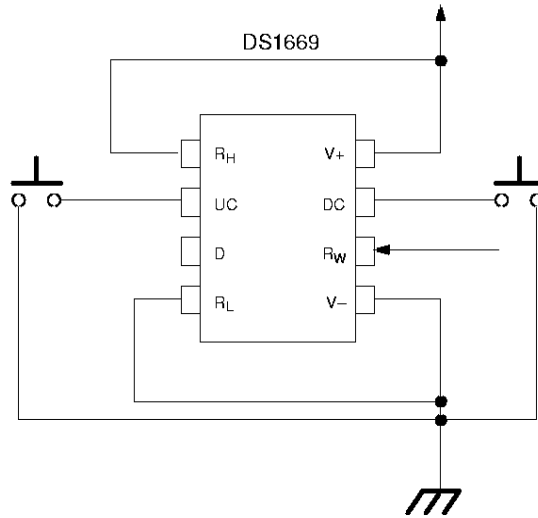

Dallastats interpret input pulse widths as the means of controlling wiper movement. A single pulse width input over the UC, DC, or D terminals will cause the wiper position to move 1/64th of the total resistance. All inputs, UC, DC, or D, are inactive when in the high state. A transition from a high to low on these inputs is considered the beginning of pulse activity.

A single pulse is defined as being greater than 1 ms but lasting no longer than a second when using the contact closure inputs UC and DC. When using the D input a single pulse is defined as being greater than 1 μ s but lasting no longer than 1 second. This is shown in Figures 4a and 6a. Repetitive pulsed inputs can be used to step through each resistive position of the device (see Figures 4a and 6b). The requirement for repetitive pulsed inputs is that pulses must be separated by a minimum time of 1 ms. If not, the Dallastat will interpret repetitive pulses as a single continuous pulse.

Pulse inputs lasting longer than 1 second will cause the wiper to move one position every 100 ms following the initial 1 second hold time. The total time to transcend the entire potentiometer using a continuous input pulse is given in the equation below:

$$1 \text{ (second)} + 63 \times 100 \text{ ms} = 7.3 \text{ (seconds)}$$

In single pushbutton mode or when using the digital source input, as the wiper reaches the end of the potentiometer its direction of movement reverses. This will occur whether or not the input is a continuous pulse or a sequence of repetitive pulses. Changing the direction of wiper movement in single pushbutton mode or digital source mode is also accomplished by a period of inactivity on the UC or D inputs for (minimum) 1 second or greater. In dual pushbutton mode, the direction is controlled by the UC and DC inputs. No wait states are required to change wiper direction in dual pushbutton mode. Additionally, in dual pushbutton mode as the wiper reaches the end of the potentiometer, the direction of wiper movement will not change. Wiper position will remain at the potentiometers' end until an opposite direction input is given.

All control inputs, UC, DC, and D, are internally pulled up with a 100K ohm resistance. Additionally, the UC and DC inputs are internally debounced and require no external components for input signal conditioning.

The DS1668/DS1669 are provided with two supply inputs $-V$ and $+V$. The maximum voltage difference

between the two supply inputs is + 8.0 volts while the minimum voltage difference is +4.5 volts. All input levels are referenced to the negative supply input, $-V$. The voltage applied to any Dallastat terminal must not exceed the negative supply voltage ($-V$) by -0.5 or the positive supply voltage ($+V$) by $+0.5$ volts. The minimum logic high level must be +2.4 volts with reference to the $-V$ supply voltage input. A logic low level with reference to the $-V$ supply voltage has a maximum value of +0.8 volts. Dallastats exhibit a typical wiper resistance of 400 ohms with a maximum wiper resistance of 1000 ohms. The maximum wiper current allowed through the Dallastat is specified at 1 milliamps (see DC Electrical Characteristics).

NONVOLATILE WIPER SETTINGS

Dallastats maintain the position of the wiper in the absence of power. This feature is provided through the use of EEPROM type memory cell arrays. During normal operation the position of the wiper is determined by the input multiplexer. Periodically, the multiplexer will update the EEPROM memory cells. The manner in which an update occurs has been optimized for reliability, durability, and performance. Additionally, the update operation is totally transparent to the user.

When power is applied to the Dallastat, the wiper setting will be the last recorded in the EEPROM memory cells. If the Dallastat setting is changed after power is applied, the new value will be stored after a delay of 2 seconds. The initial storage of a new value after power-up, occurs when the first change is made, regardless of when this change is made.

After the initial change on power-up, subsequent changes in the Dallastat EEPROM memory cells will occur only if the wiper position of the part is moved greater than 12.5% of the total resistance range. Any wiper movement after initial power-up which is less than 12.5% will not be recorded in the EEPROM memory cells. Since the Dallastat contains a 64-to-1 multiplexer, a change of greater than 12.5% corresponds to a change of the fourth LSB.

Changes or storage to the EEPROM memory cells must allow for a 2 second delay to guarantee that updates will occur. The EEPROM memory cells are specified to accept greater than 80,000 writes before a wear-out condition. If the EEPROM memory cells do reach a wear-out condition, the Dallastat will still function properly while power is applied. However, on power-up the device's wiper position will be that of the position last recorded before memory cell wear out.

DS1668 DALLASTAT™ BLOCK DIAGRAM Figure 3

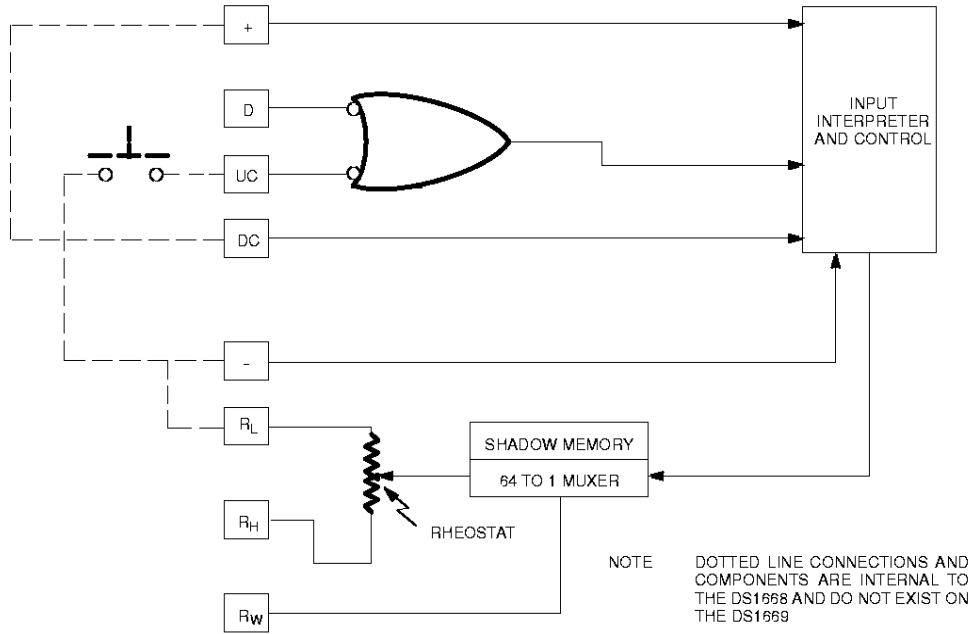

FLOWCHART: ONE BUTTON OPERATION AND ELECTRICAL CONTROL Figure 4

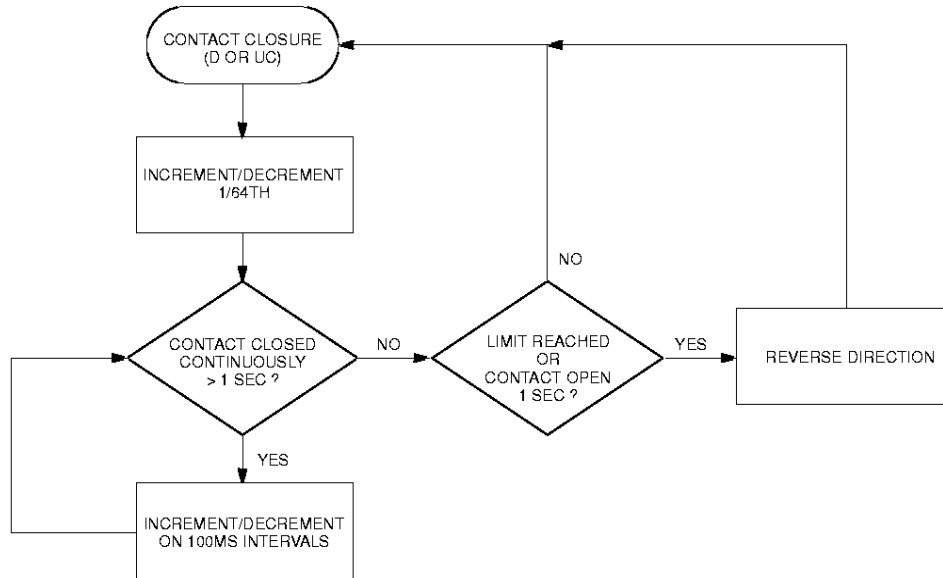

CONTACT OPEN AND CONTACT CLOSURE TIMING IS $1s \pm 10\%$

FLOWCHART: TWO BUTTON OPERATION Figure 5

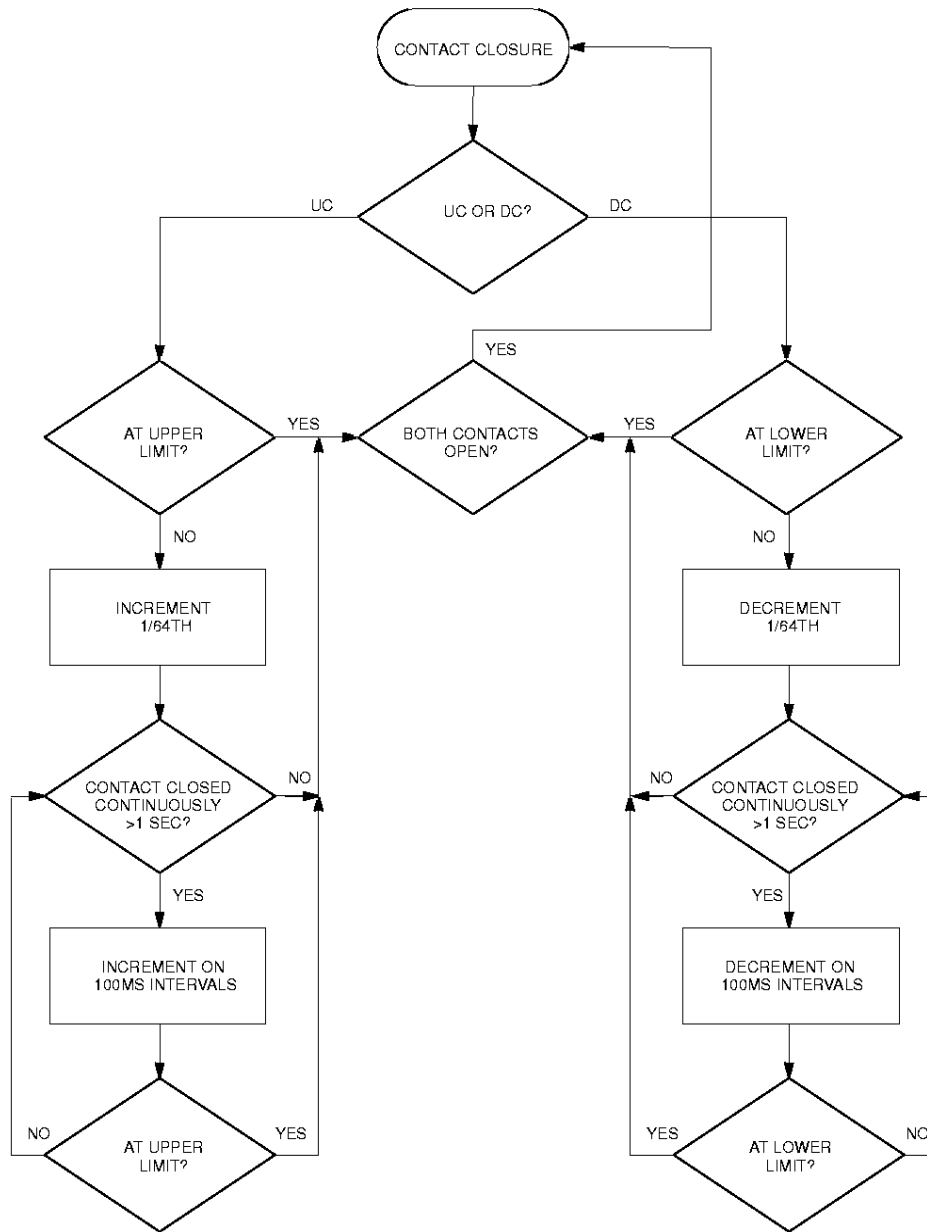

CONTACT OPEN AND CONTACT CLOSURE TIMING IS 1 sec. ± 10%

ABSOLUTE MAXIMUM RATINGS*

Voltage on Any Pin Relative to -V	-V -0.5V + 8.0V
Operating Temperature	0°C to 70°C commercial; -40°C to +85°C industrial
Storage Temperature	-55°C to +125°C
Soldering Temperature	260°C for 15 seconds

* This is a stress rating only and functional operation of the device at these or any other conditions above those indicated in the operation sections of this specification is not implied. Exposure to absolute maximum rating conditions for extended periods of time may affect reliability.

RECOMMENDED DC OPERATING CONDITIONS

(-40°C to +85°C)

PARAMETER	SYMBOL	MIN	TYP	MAX	UNITS	NOTES
+ Supply Voltage	+V	-V + 4.5		-V + 8.0	V	
- Supply Voltage	-V	+V - 8.0		+V - 4.5	V	
Rheostat Inputs	R _H , R _W , R _L	-V - 0.5		+V + 0.5	V	
Logic Input 1	V _{IH}	+2.4			V	1, 2
Logic Input 0	V _{IL}			+0.8	V	1, 2

DC ELECTRICAL CHARACTERISTICS

(-40°C to +85°C; -V to +V = 4.5V to 8.0V)

PARAMETER	SYMBOL	MIN	TYP	MAX	UNITS	NOTES
+, - Supply Current	I _{CC1}		1	2	mA	3
Supply Current, Idle State	I _{CC2}			65	μA	9
Wiper Resistance	R _W		400	1000	Ω	
Wiper Current	I _W			1	mA	5
Rheostat Current	I _H , I _L			1	mA	5
Power-Up Time	t _{PU}			10	μs	10
Input Leakage	I _{LI}	-1		+1	μA	1

AC ELECTRICAL CHARACTERISTICS

(-40°C to +85°C; -V to +V = 4.5V to 8.0V)

PARAMETER	SYMBOL	MIN	TYP	MAX	UNITS	NOTES
Digital Input Pulse Width	t _{DPW}	1		DC	μs	1, 7, 8
Contact Pulse Width	t _{CPW}	1		DC	ms	1, 7, 8
Repetitive Input Pulse High Time	t _{HPW}	1		DC	ms	1, 7, 8
Continuous Input Pulse	t _{CCP}	1		DC	s	1, 7, 8

ANALOG RESISTOR CHARACTERISTICS

(-40°C to +85°C)

PARAMETER	SYMBOL	MIN	TYP	MAX	UNITS	NOTES
End-to-End Resistor Tolerance		-20		+20	%	
Absolute Linearity		-0.75		+0.75	LSB	11
Relative Linearity		-0.3		+0.3	LSB	12
-3 dB Cutoff Frequency Noise Figure	f _{cutoff}				Hz	13
Temperature Coefficient		-800		+800	ppm/C	

CAPACITANCE

(t_A=25°C)

PARAMETER	SYMBOL	MIN	TYP	MAX	UNITS	NOTES
Input Capacitance	C _{IN}			5	pF	6
Output Capacitance	C _{OUT}			7	pF	6

TIMING DIAGRAMS Figure 6

(A) SINGLE PULSE INPUTS

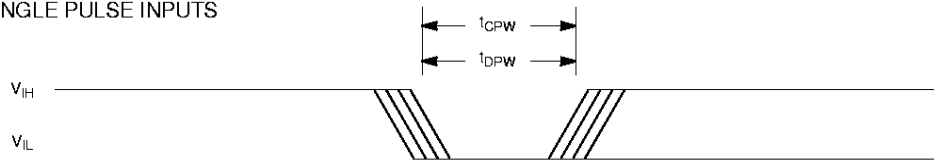

(B) REPETITIVE PULSE INPUTS

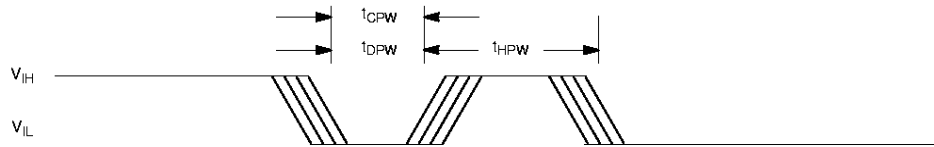

(C) CONTINUOUS PULSE INPUTS

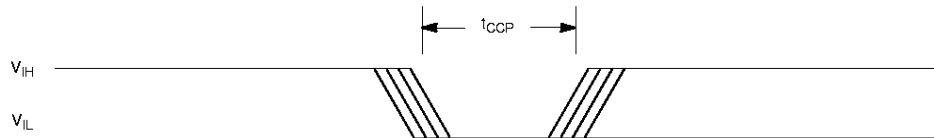

NOTES:

1. All inputs; UV, DC, and D are internally pulled up with a resistance of 100K Ω .
2. Input logic levels are referenced to -V.
3. I_{CC} is the internal current that flows between -V and +V.
4. Input leakage applies to contact inputs UC and DC and digital input (D).
5. Wiper current and rheostat currents are the maximum current which can flow in the resistive elements.
6. Capacitance values apply at 25°C.
7. Input pulse width is the minimum time required for an input to cause an increment or decrement. If the UC, DC or D input is held active for longer than 1 second, subsequent increments or decrements will occur on 100 ms intervals until the inputs UC, DC, and/or D is released to V_{IH}.
8. Repetitive pulsed inputs on UC, DC, or D will be recognized as long as the pulse repetition occurs within 1 second of each other. Pulses occurring faster than 1 ms apart may not be recognized as individual inputs but can be interpreted a constant input.
9. Idle state supply current is measured with no pushbutton depressed and with the wiper. R_W tied to a CMOS load.
10. Maximum time required for the Dallastat to determine single or dual push button operation after input supply has reached 10% recommended supply operating conditions.
11. Absolute linearity is used to determine wiper voltage versus expected voltage as determined by wiper position.
12. Relative linearity is used to determine the change in voltage between successive tap positions.
13. -3 dB cutoff frequency characteristics for the DS1669 depend on potentiometer total resistance:
DS1669-010; 1 MHz, DS1669-050; 200 KHz, DS1669-100; 100 KHz.

DS1668 PUSHBUTTON DIMENSIONS

