

Dual-band Low Noise Amplifier/Mixer

Description

The CXG1115ER is a dual-band (CDMA/GPS) low noise amplifier/mixer MMIC for the Japan CDMA cellular phones (J-CDMA). This IC is designed using the Sony's GaAs J-FET process.

Features

- High gain:
 - CDMA LNA High current mode
Gp = 14.5dB (Typ.)
 - CDMA MIX
Gc = 12dB (Typ.)
 - GPS LNA
Gp = 18dB (Typ.)
 - GPS MIX
Gc = 9.5dB (Typ.)
- Low noise figure:
 - CDMA LNA High current mode
NF = 1.5dB (Typ.)
 - CDMA MIX
NF = 4.5dB (Typ.)
 - GPS LNA
NF = 1.7dB (Typ.)
 - GPS MIX
NF = 5dB (Typ.)
- Low distortion
 - CDMA LNA High current mode
Input IP3 = +3.5dBm (Typ.)
 - CDMA MIX
Input IP3 = +2dBm (Typ.)
 - GPS LNA
Input IP3 = -5.5dBm (Typ.)
 - GPS MIX
Input IP3 = +2dBm (Typ.)
- Low noise amplifier with by-pass switch
- J-CDMA/GPS supported dual band
- Sharing the two-system LO signal source by the doubler system
- 24-pin VQFN small package

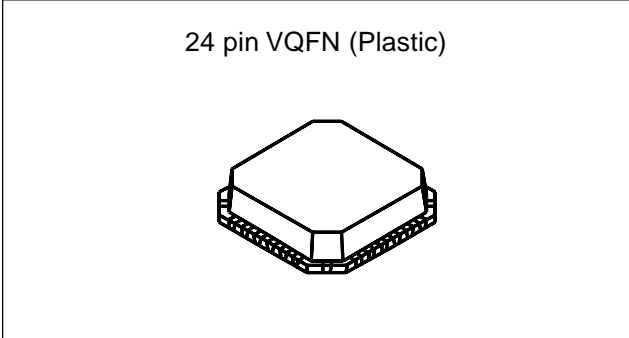

Applications

J-CDMA

Structure

GaAs J-FET MMIC

Absolute Maximum Ratings (Ta = 25°C)

• Supply voltage	VDD	4.5	V
• Input power	PIN	+5	dBm
• Operating temperature	Topr	-35 to +85	°C
• Storage temperature	Tstg	-65 to +150	°C

Recommended Operating Conditions

• Supply voltage	VDD	2.7 to 3.3	V
• Control voltage	VCTL (H)	2.4 to 3.3	V
	VCTL (L)	0 to 0.3	V

Block Diagram and Pin Configuration

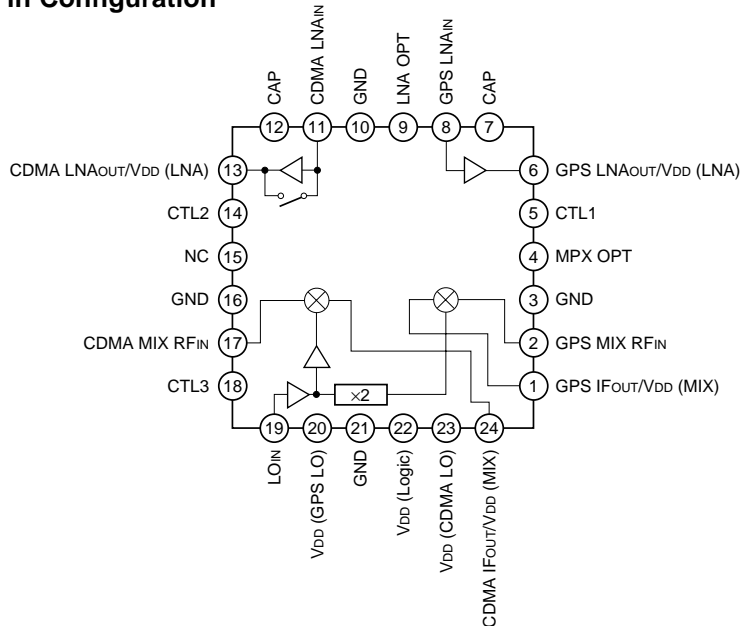

GaAs MMICs are ESD sensitive devices. Special handling precautions are required.

Sony reserves the right to change products and specifications without prior notice. This information does not convey any license by any implication or otherwise under any patents or other right. Application circuits shown, if any, are typical examples illustrating the operation of the devices. Sony cannot assume responsibility for any problems arising out of the use of these circuits.

Electrical Characteristics

Conditions: $V_{DD} = 2.7V$, $V_{CTL} (H) = 2.7V$, $V_{CTL} (L) = 0V$, ($T_a = 25^{\circ}C$)

Logic Block

Item	Symbol	Min.	Typ.	Max.	Unit	Condition
Control pin current	$I_{CTL} (H)$	—	35	50	μA	When no signal
Logic power current consumption	I_{DD}	—	0.3	0.6	mA	

CDMA-LNA Block Conditions: $f_{RF} = 850MHz$

Item	Control pin condition			Symbol	Min.	Typ.	Max.	Unit	Condition
	V_{CTL1}	V_{CTL2}	V_{CTL3}						
Current consumption	L	L	L	I_{DDSW}	—	0.1	0.3	mA	When no signal
	L	L	H	I_{DDM}	—	5	7		
	L	H	L	I_{DDL}	—	3.2	5		
	L	H	H	I_{DDH}	—	5.3	7.5		
Power gain	L	L	L	G_{PSW}	-4.3	-3.8	-3.3	dB	When a small signal
	L	L	H	G_{PM}	6	7	8		
	L	H	L	G_{PL}	12	13.5	15		
	L	H	H	G_{PH}	13	14.5	16		
	H	—	—	G_{POFF}	—	-13	-8		
Noise figure	L	L	H	N_{FM}	—	8	10	dB	
	L	H	L	N_{FL}	—	1.5	2		
	L	H	H	N_{FH}	—	1.5	2		
Input IP3	L	L	L	$IIP3_{SW}$	20	28	—	dBm	*1
	L	L	H	$IIP3_M$	6	8.5	—		
	L	H	L	$IIP3_L$	-1.5	1	—		
	L	H	H	$IIP3_H$	1.5	3.5	—		
Isolation	L	L	H	I_{SOM}	21	26	—	dB	When a small signal
	L	H	L	I_{SOL}	13	18	—		
	L	H	H	I_{SOH}	13	18	—		

*1 Conversion from the IM3 suppression ratio for two-wave input: $f_{RF} = 850MHz/850.9MHz$, $P_{RF} = 0dBm$ (G_{PSW} mode), $P_{RF} = -20dBm$ (G_{PM} mode), $P_{RF} = -25dBm$ (G_{PL}/G_{PH} mode).

CDMA-MIX Block Conditions: $f_{RF} = 850\text{MHz}$, $f_{LO} = f_{RF} - f_{IF}$, $f_{IF} = 110\text{MHz}$, $P_{LO} = -10\text{dBm}$

Item	Control pin condition			Symbol	Min.	Typ.	Max.	Unit	Condition
	V _{CTL1}	V _{CTL2}	V _{CTL3}						
Current consumption	L	—	—	I _{DD}	—	8	11	mA	When no signal
Conversion gain	L	—	—	G _C	10.5	12	13.5	dB	When a small signal
	H	—	—	G _{COFF}	—	-55	-45		
Noise figure	L	—	—	NF	—	4.5	6	dB	
Input IP3	L	—	—	IIP3	0	2	—	dBm	*2
LO – RF leak	L	—	—	PLK	—	-23	-18	dBm	—

*2 Conversion from the IM3 suppression ratio for two-wave input: $f_{RF} = 850\text{MHz}/850.9\text{MHz}$, $P_{RF} = -25\text{dBm}$.

GPS-LNA Block Conditions: $f_{RF} = 1575\text{MHz}$

Item	Control pin condition			Symbol	Min.	Typ.	Max.	Unit	Condition
	V _{CTL1}	V _{CTL2}	V _{CTL3}						
Current consumption	H	—	—	I _{DD}	—	5.5	7.5	mA	When no signal
Conversion gain	H	—	—	G _P	16.5	18	19.5	dB	When a small signal
	L	—	—	G _{POFF}	—	-22	-17		
Noise figure	H	—	—	NF	—	1.7	2.2	dB	
Input IP3	H	—	—	IIP3	-8	-5.5	—	dBm	*3
Isolation	H	—	—	I _{SO}	23	28	—	dB	When a small signal

*3 Conversion from the IM3 suppression ratio for two-wave input: $f_{RF} = 1574.5\text{MHz}/1575.5\text{MHz}$, $P_{RF} = -30\text{dBm}$.

GPS-MIX Block Conditions: $f_{RF} = 1575\text{MHz}$, $f_{LO} = (f_{RF} - f_{IF})/2$, $f_{IF} = 110\text{MHz}$, $P_{LO} = -10\text{dBm}$

Item	Control pin condition			Symbol	Min.	Typ.	Max.	Unit	Condition
	V _{CTL1}	V _{CTL2}	V _{CTL3}						
Current consumption	H	—	—	I _{DD}	—	8	11	mA	When no signal
Conversion gain	H	—	—	G _C	8	9.5	11	dB	When a small signal
	L	—	—	G _{COFF}	—	-50	-40		
Noise figure	H	—	—	NF	—	5	6.5	dB	
Input IP3	H	—	—	IIP3	-1.5	2	—	dBm	*4
LO – RF leak	H	—	—	PLK	—	-15	-10	dBm	@ $f_{LO} = f_{RF} - f_{IF}$

*4 Conversion from the IM3 suppression ratio for two-wave input: $f_{RF} = 1574.5\text{MHz}/1575.5\text{MHz}$, $P_{RF} = -25\text{dBm}$.

Recommended Evaluation Circuit

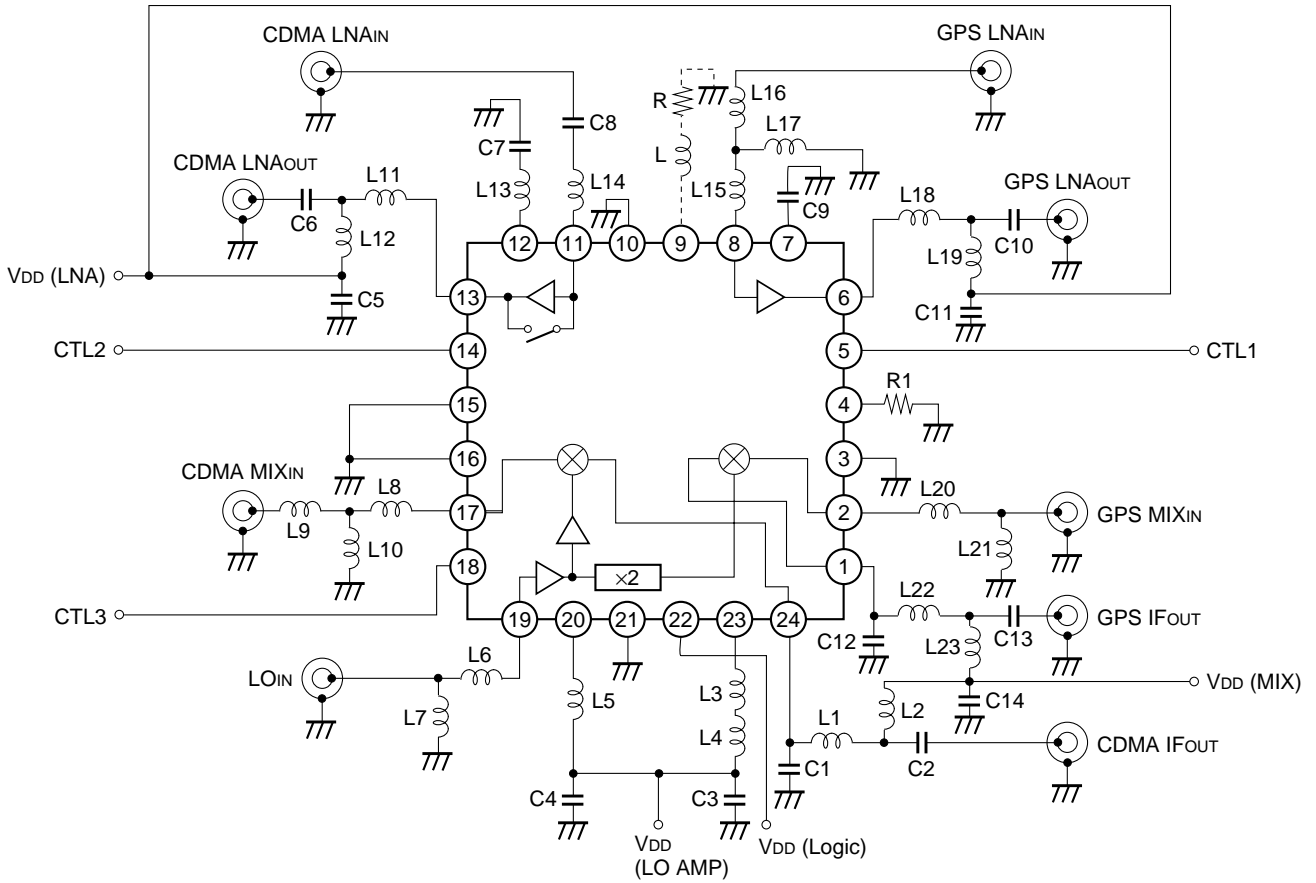

L1	220nH	L16	3.3nH	C8	100pF
L2	220nH	L17	8.2nH	C9	18pF
L3	27nH	L18	6.8nH	C10	100pF
L4	5.6nH	L19	3.9nH	C11	1000pF
L5	6.8nH	L20	10nH	C12	8pF
L6	33mH	L21	2.7nH	C13	1000pF
L7	12nH	L22	220nH	C14	1000pF
L8	27nH	L23	220nH	R1	100Ω
L9	18nH	C1	8pF	L*1	33nH
L10	22nH	C2	1000pF	R*1	—
L11	22nH	C3	1000pF		
L12	27nH	C4	100pF		
L13	2.2nH	C5	100pF		
L14	22nH	C6	1000pF		
L15	5.6nH	C7	1000pF		

*1 L and R of Pin 9 are used when the optional resistor is added in the low noise amplifier block.

Example of Representative Characteristics (Ta = 25°C)

Low Noise Amplifier Block

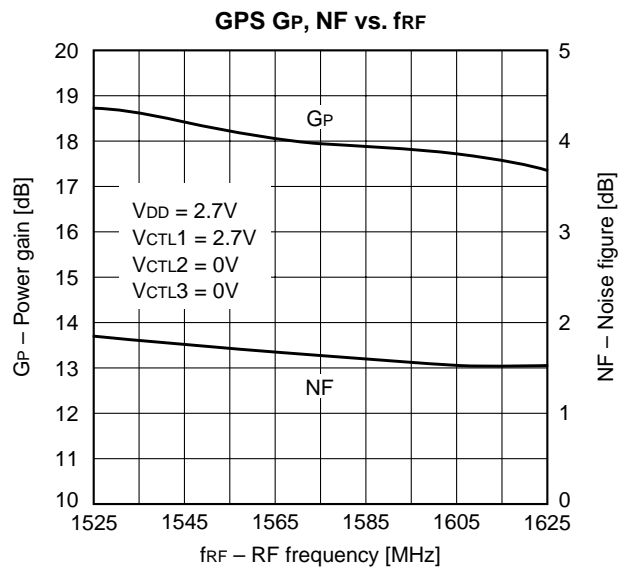
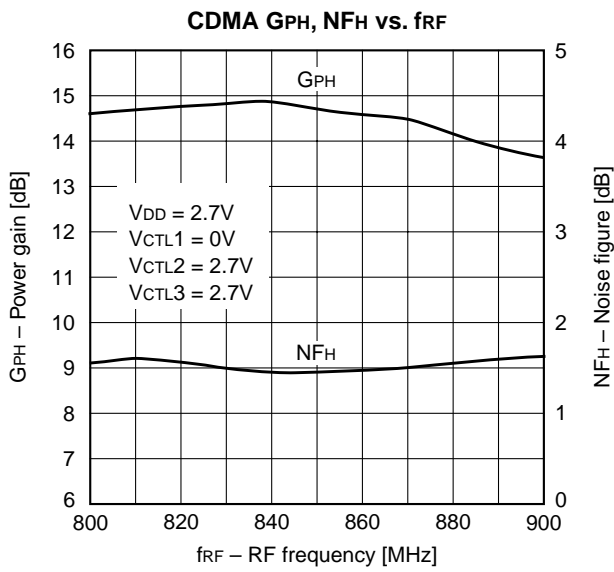
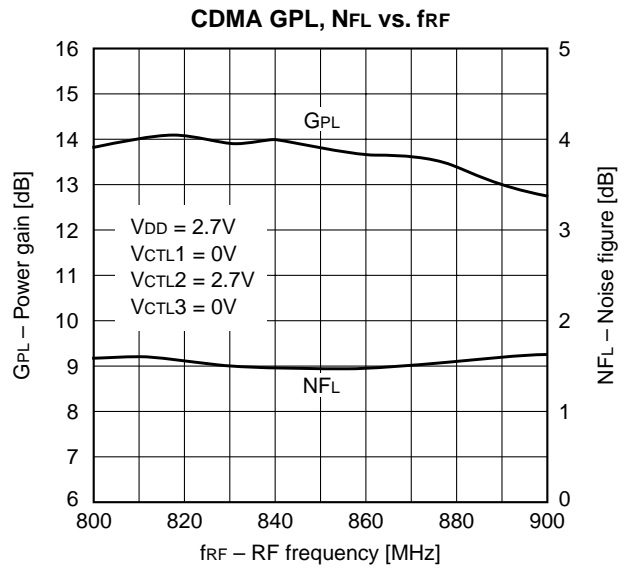
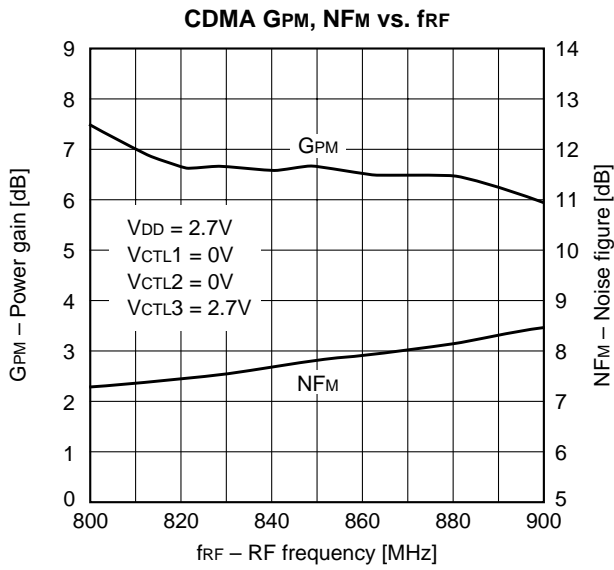

Low Noise Amplifier Block

CDMA Pout, IM3M vs. Pin

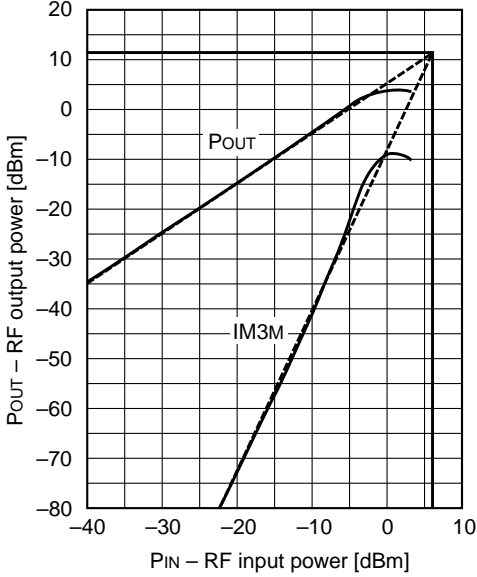

CDMA Pout IM3L vs. Pin

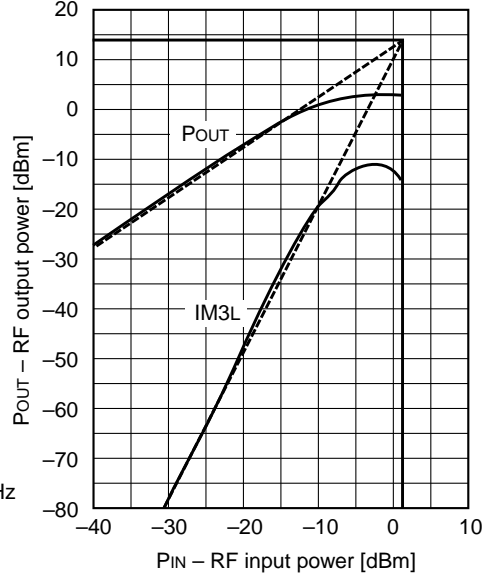

CDMA Pout, IM3H vs. Pin

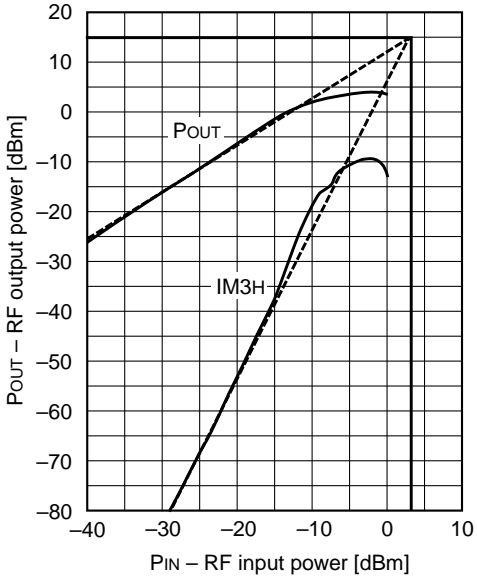

GPS Pout IM3 vs. Pin

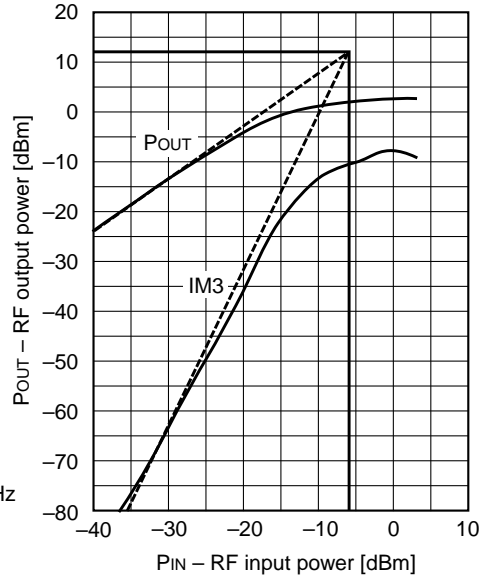

Mixer Block

CDMA Gc, NF vs. fRF

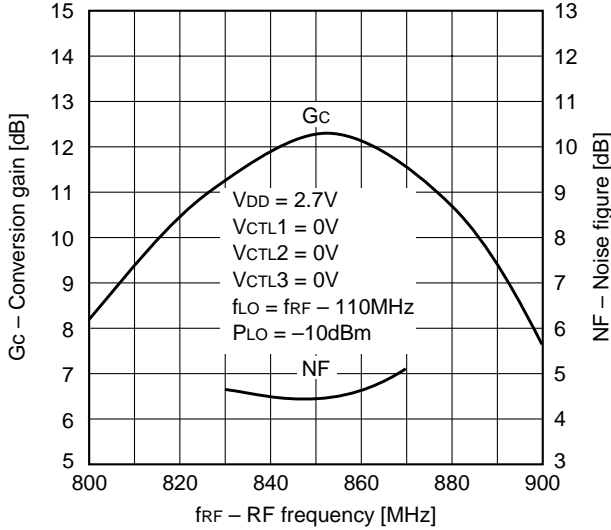

GPS Gc, NF vs. fRF

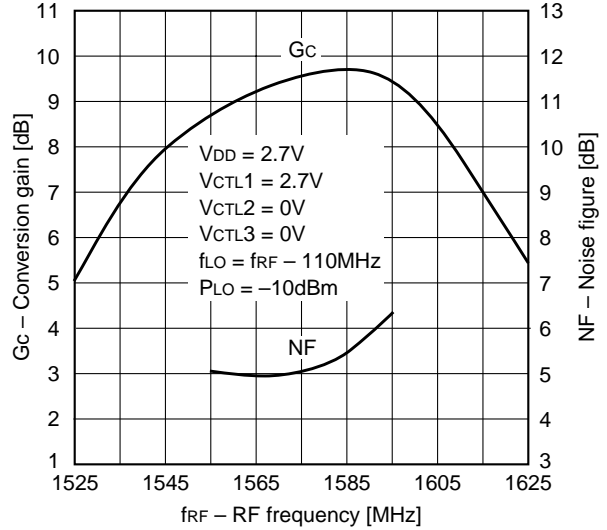

CDMA POUT, IM3 vs. PIN

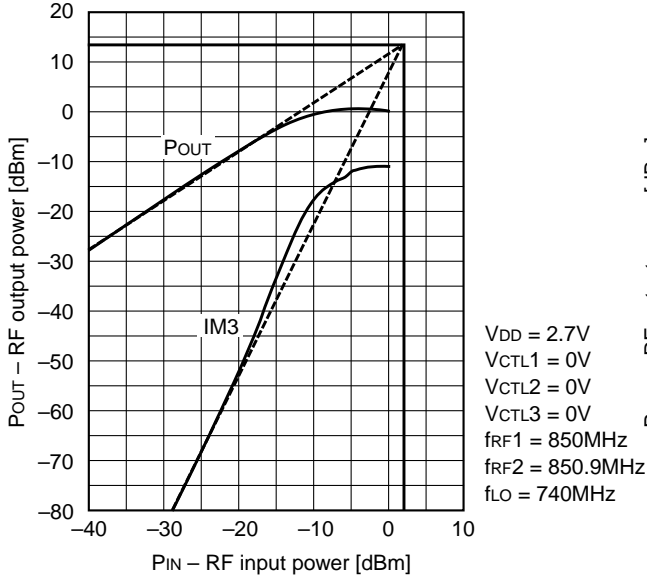

GPS POUT, IM3 vs. PIN

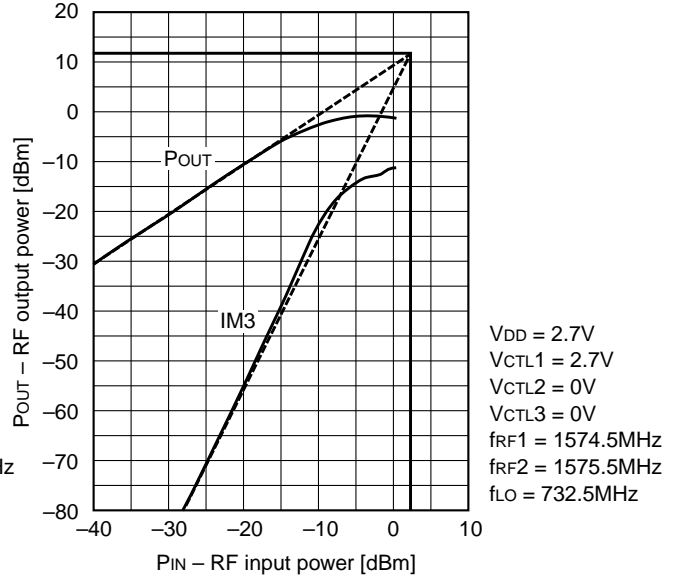

Mixer Block

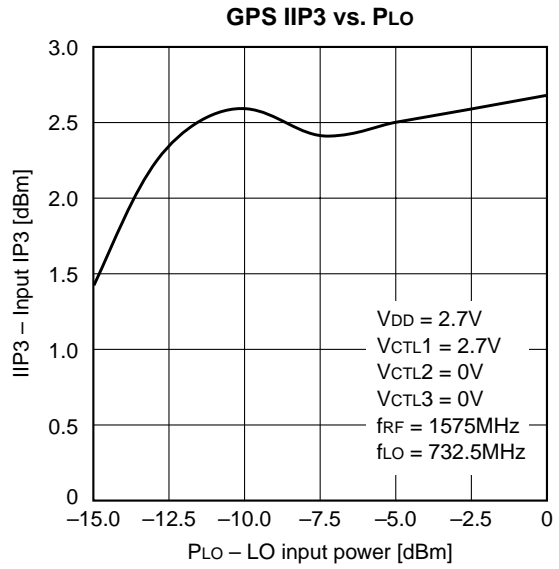
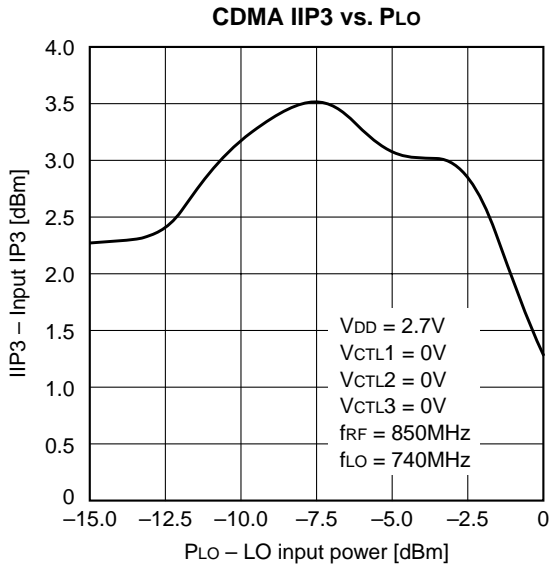
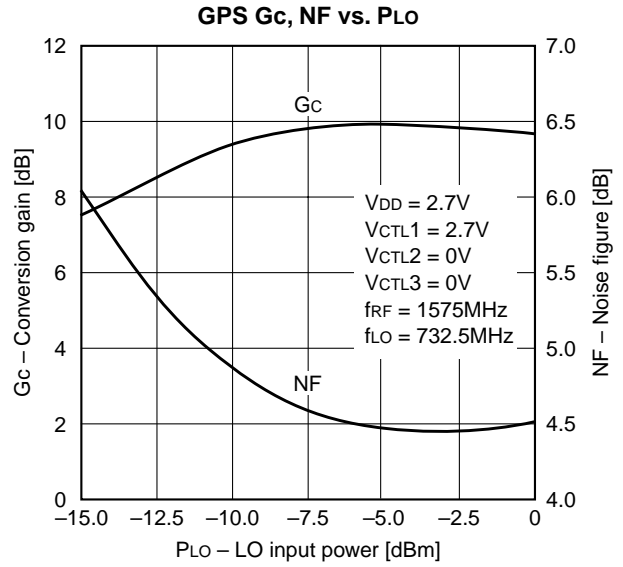
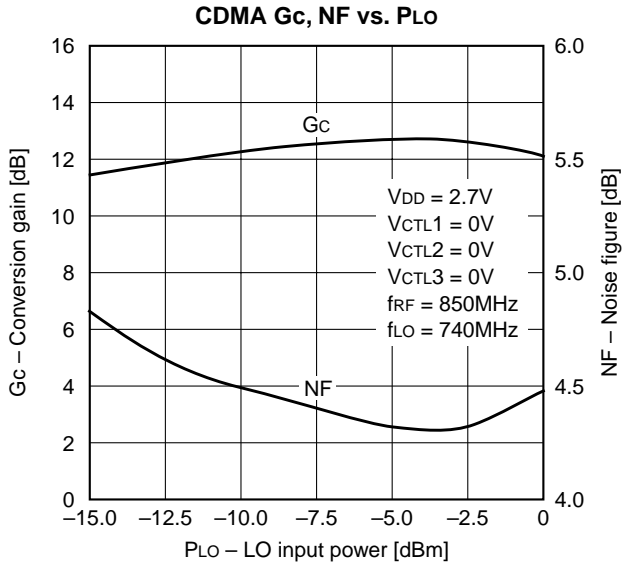

Characteristics Example When the Optional Resistor R is Added (Ta = 25°C)

Low Noise Amplifier Block

* Measured with the choke inductor (L = 33nH) for decoupling inserted to Pin 9 (LNA OPT pin) in series.

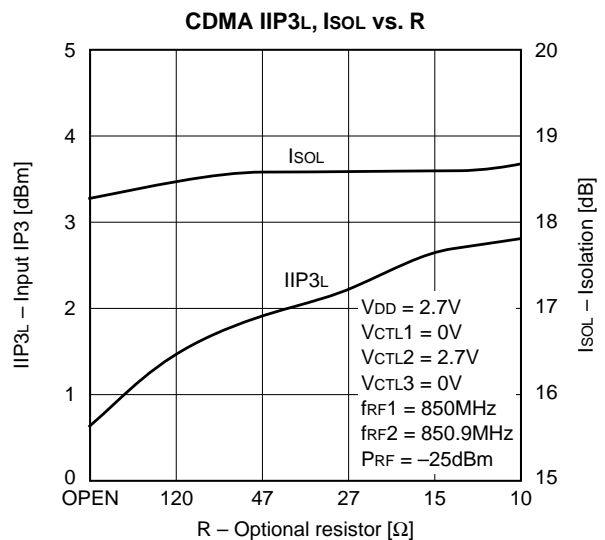
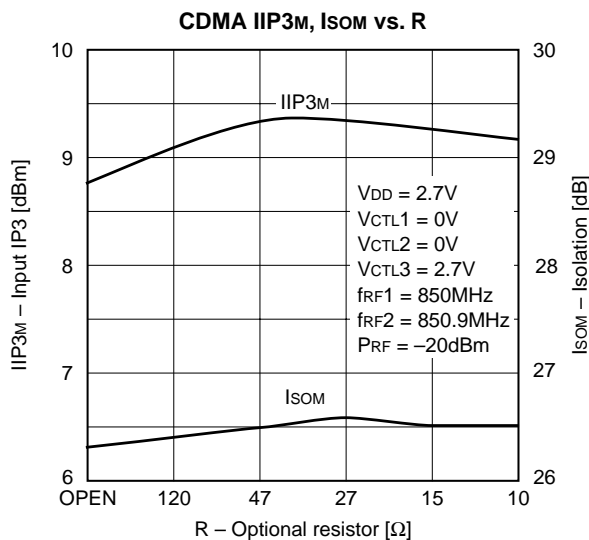
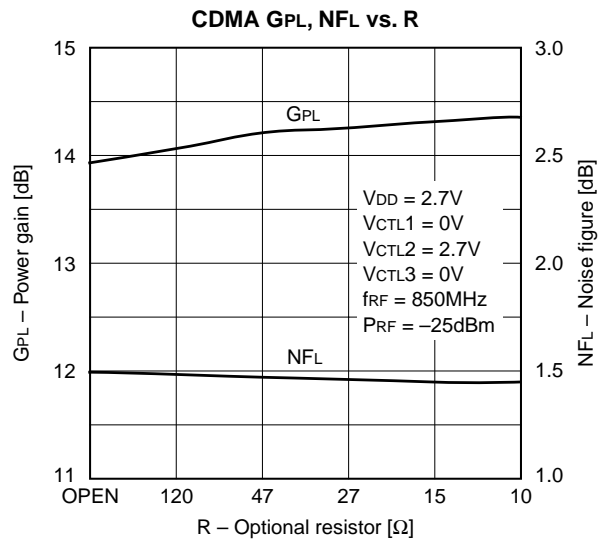
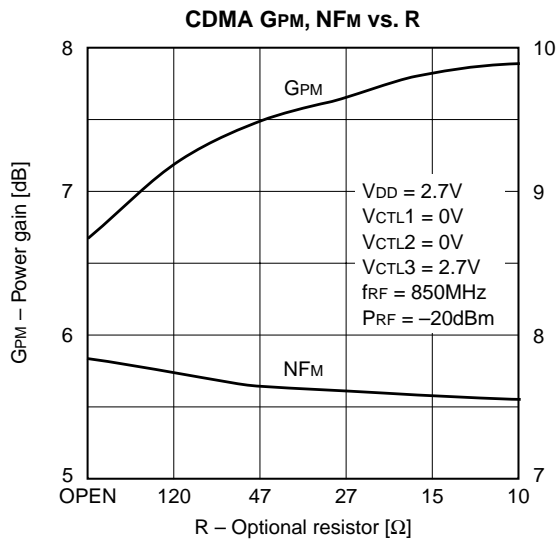
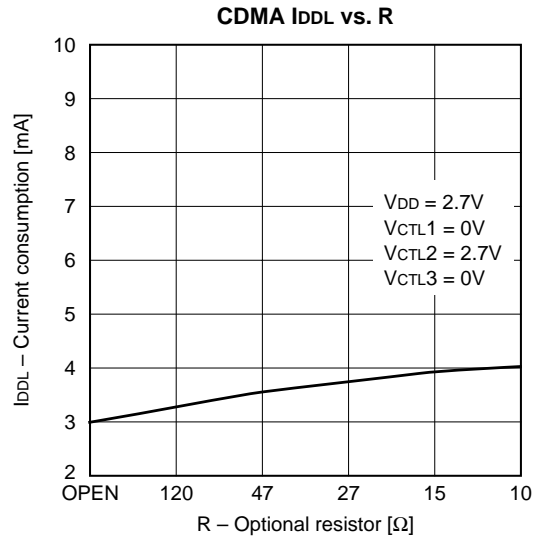
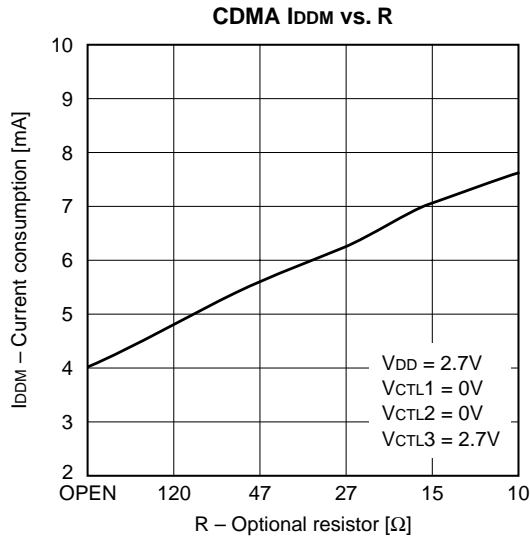

Low Noise Amplifier Block

* Measured with the choke inductor (L = 33nH) for decoupling inserted to Pin 9 (LNA OPT pin) in series.

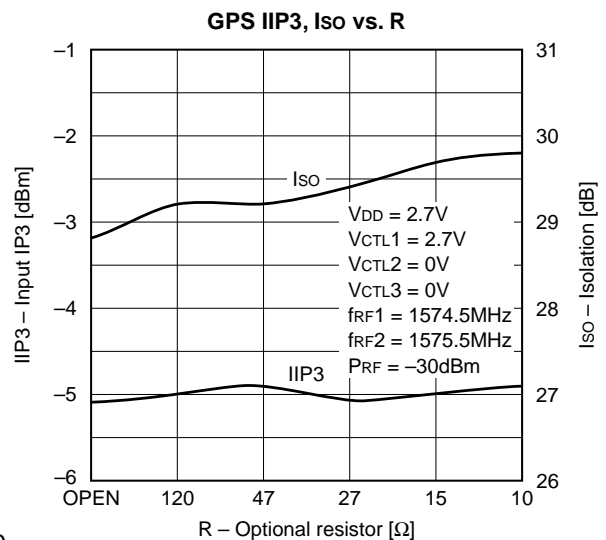
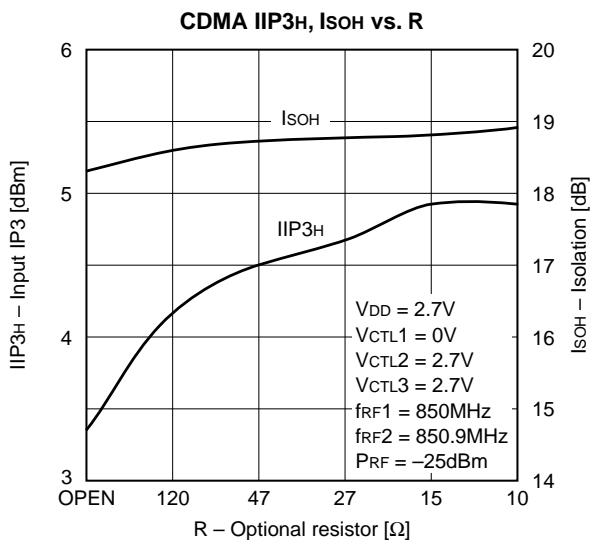
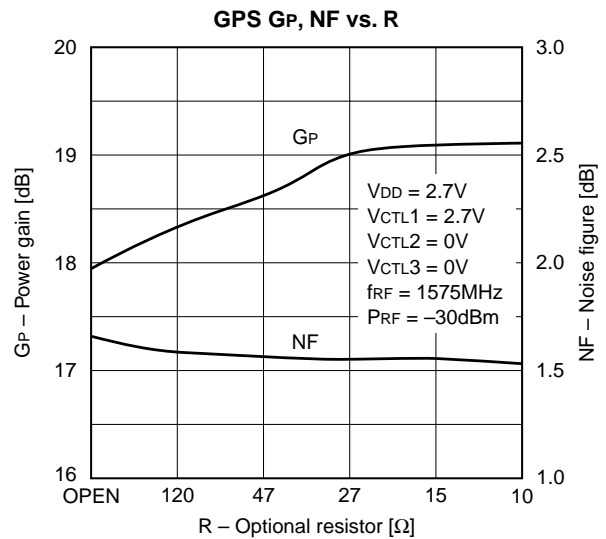
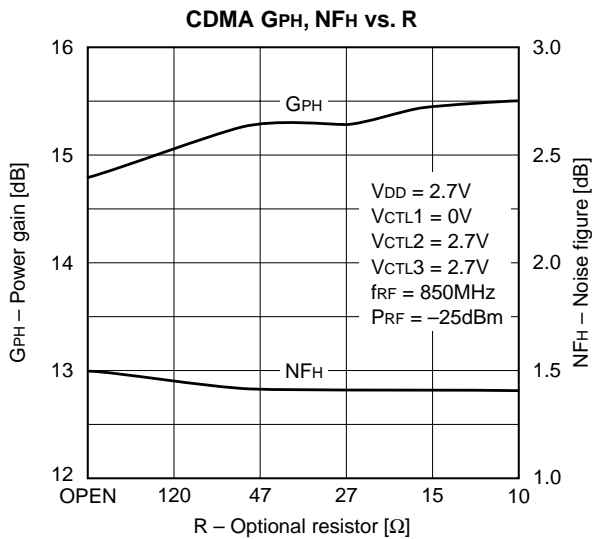
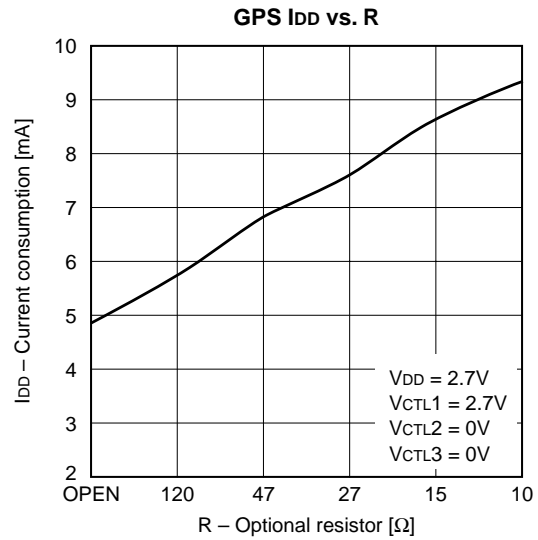
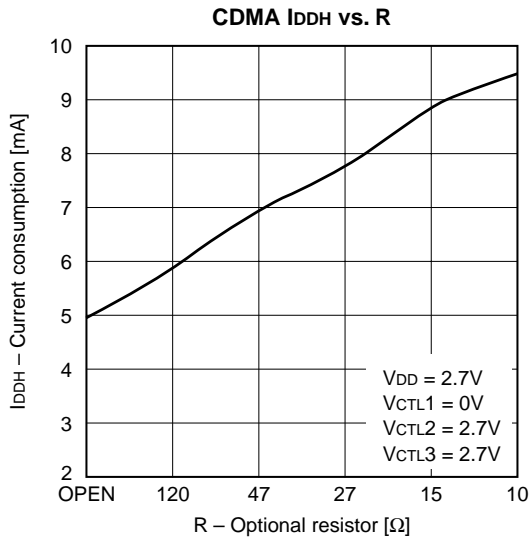

Characteristics Example When the Optional Resistor R is Added (Ta = 25°C)

Mixer Block

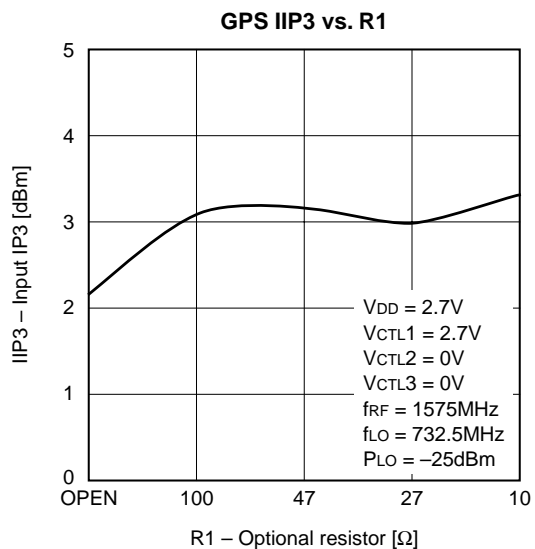
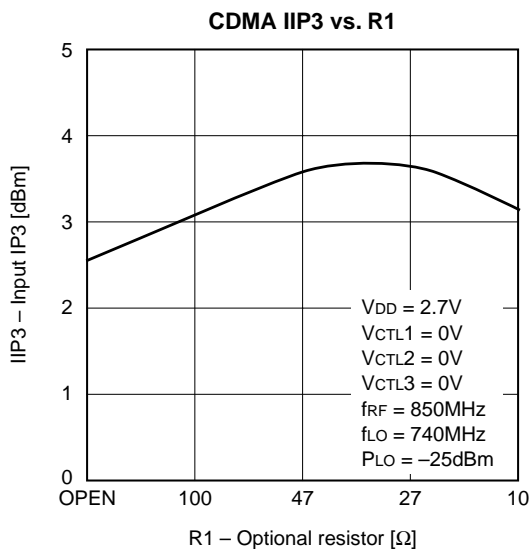
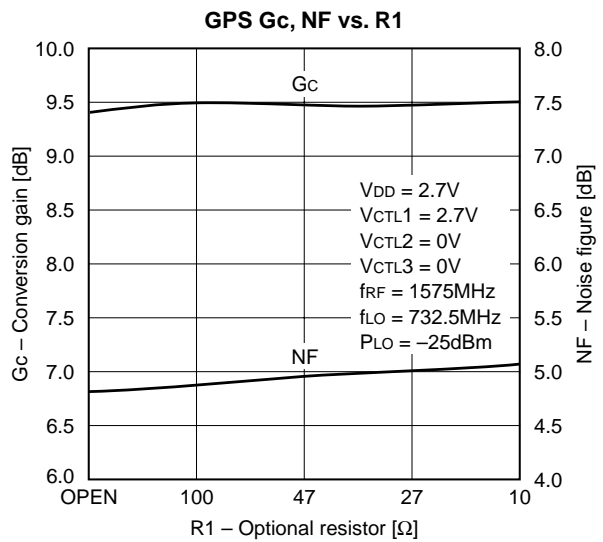
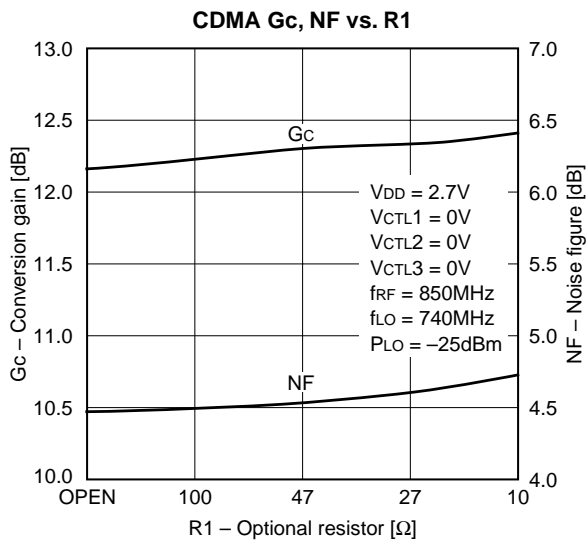
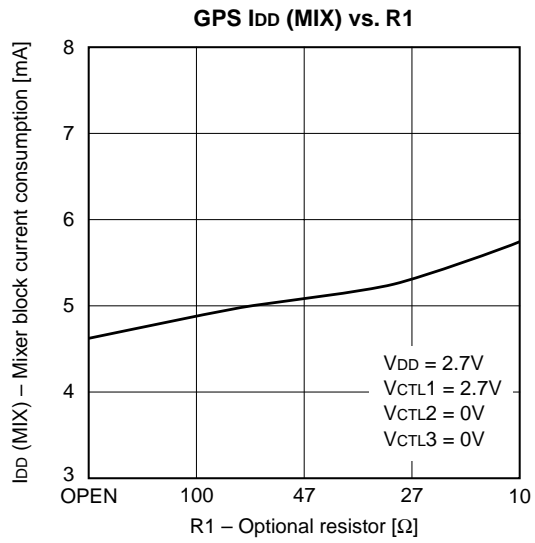
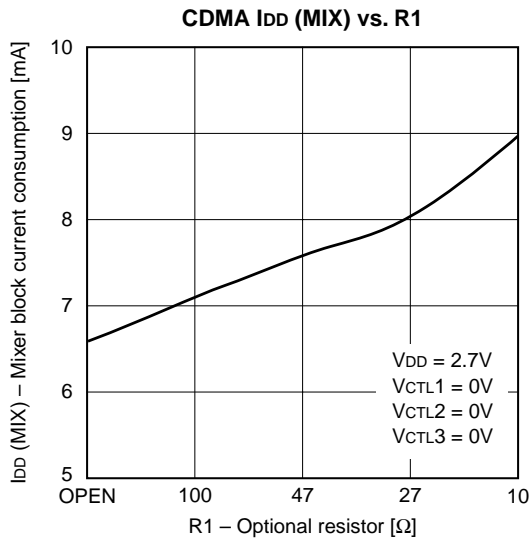

Recommended Evaluation Board

Front

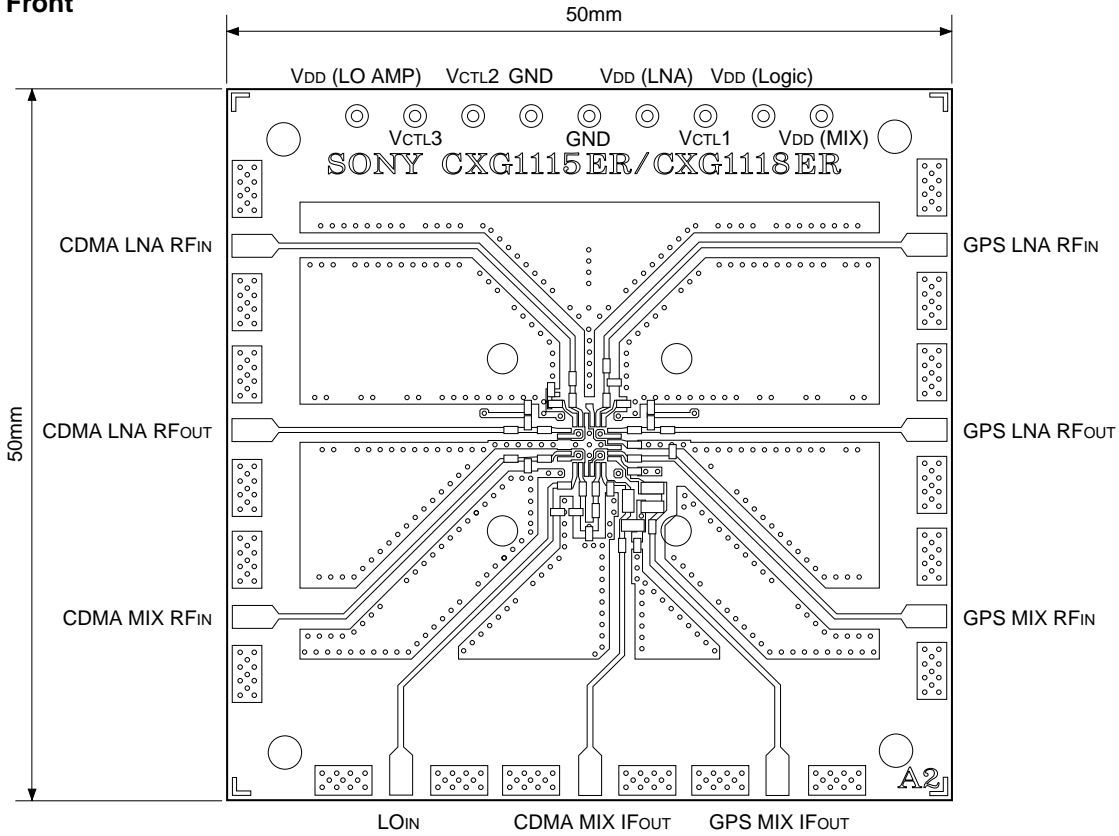

Glass fabric-base 4-layer epoxy board (thickness: 0.2mm × 2)
GND for the whole 2nd and 3rd layers

Enlarged Diagram of Center Part

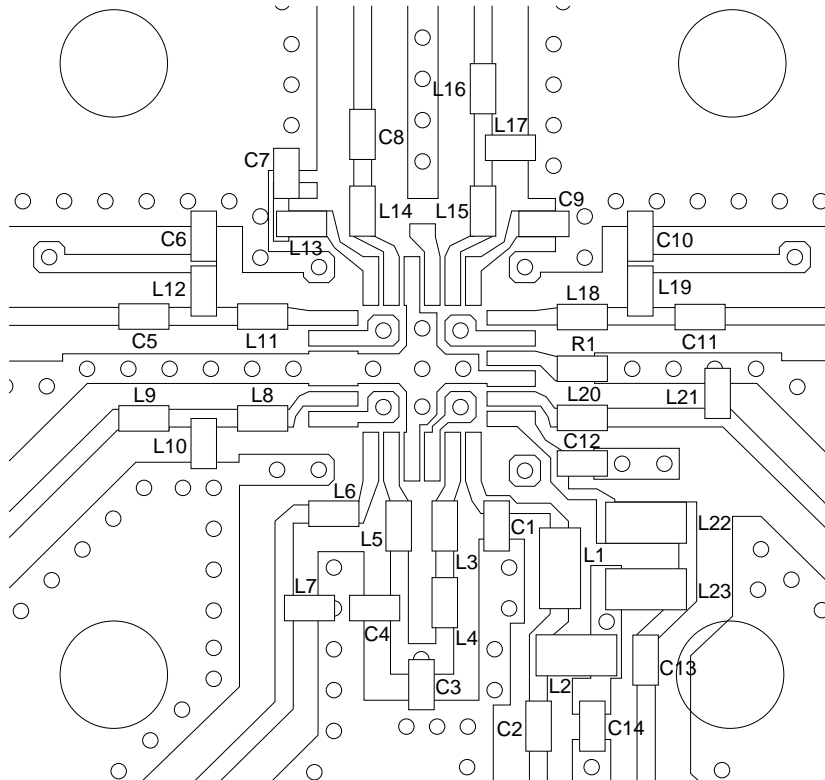

Package Outline Unit: mm

24PIN VQFN(PLASTIC)

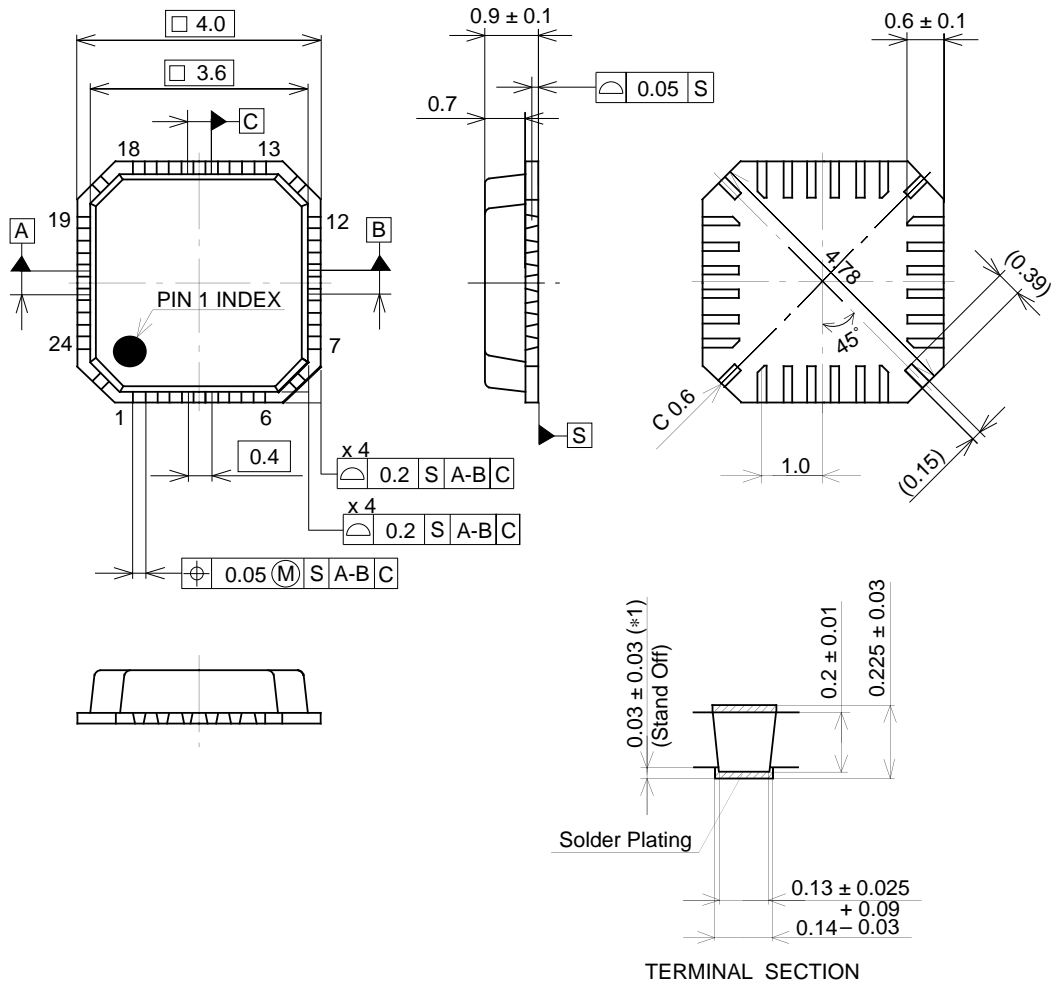

PACKAGE STRUCTURE

PACKAGE MATERIAL	EPOXY RESIN
LEAD TREATMENT	SOLDER PLATING
LEAD MATERIAL	COPPER ALLOY
PACKAGE MASS	0.04g

LEAD SPECIFICATIONS

ITEM	SPEC.
LEAD MATERIAL	COPPER ALLOY
SOLDER PLATING	Sn-Bi Bi:1-4wt%
LEAD TREATMENT THICKNESS	5-18µm