

**SOT-25**



**Pin Definition:**

- 1. SW
- 2. Ground
- 3. Feedback
- 4. CTRL
- 5. Input

### General Description

The TS1520 is a step-up DC-DC converter; operates as current source to drive up to 18 white LEDs in parallel/series configuration. Series connecting of the LEDs provides identical LED currents resulting in uniform brightness and eliminating the need for ballast resistors. The light intensity of these LEDs is proportional to the current passing through them. The TS1520 switches at a fixed frequency of 700KHz, allowing the use of tiny, low profile inductors and capacitors to minimize footprint and cost in space consideration applications for cellular phone backlighting or other hand held equipment. The TS1520 can drive up to 18 white LEDs from 4.5V supply. The wide input voltage range from 2.7V to 7V is ideal for portable (5V) applications with higher conversion efficiency. To control LED brightness, the LED current can be pulsed by applying a PWM (pulse width modulated) signal with a frequency range of 100Hz to 50KHz to the CTRL pin. TS1520 has integrated Over Voltage Protection that prevents damage to the device in case of a high impedance output due to faulty LED or open circuit caused by abnormal conditions.

### Features

- Built-in Internal Switch
- 2.7V to 7V input range
- <1uA shutdown current
- High Efficiency
- Drives up to 3S2P to 3S6P White LEDs (V<sub>IN</sub> at 3.5V to 5V)
- Over Voltage Protection 30V

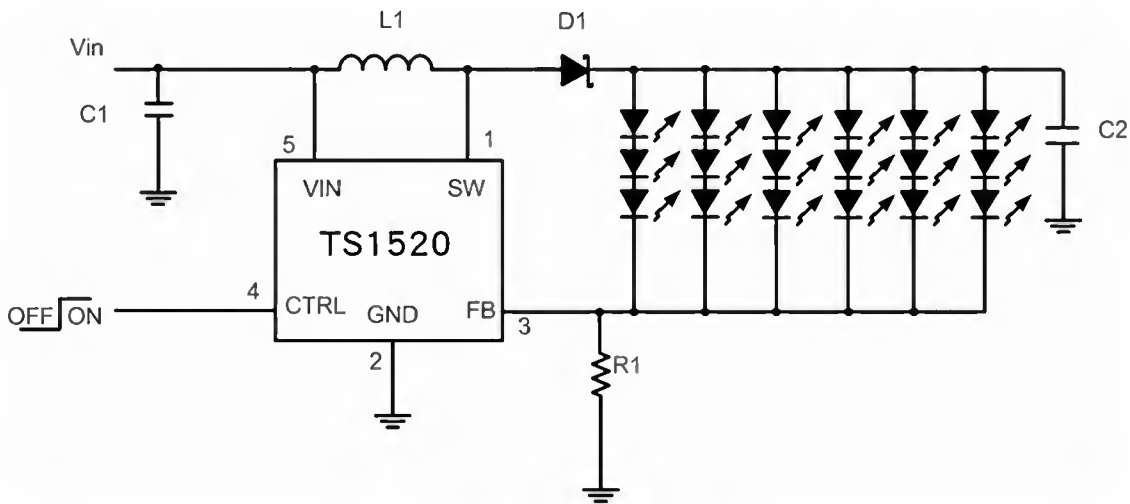
### Application

- Cellular Phones
- Digital Still Cameras
- Portable Electronics
- LCD Display Module
- White LED Backlighting
- PDAs, GPS terminals

### Ordering Information

Part No.	Package	Packing
TS1520CX5 RF	SOT-25	3Kpcs / 7" Reel

### Typical Application Circuit



### Absolute Maximum Rating

Parameter	Symbol	Limit	Unit
Input Voltage	$V_{IN}$	10	V
Supply Voltage (Recommended)	$V_{IN}$	2.7 ~ 7	V
FB Voltage	$V_{FB}$	5	V
SW Voltage	$V_{SW}$	32	V
CTRL Voltage	$V_{CTRL}$	5	V
Ambient Temperature Range	$T_A$	-40 to +85	°C
Junction Temperature Range	$T_J$	-40 to +125	°C

### Electrical Specifications ( $T_a = 25^\circ\text{C}$ , $V_{IN}=3.3\text{V}$ , $C_{IN}=1\mu\text{F}$ , $C_{OUT}=10\mu\text{F}$ unless otherwise noted)

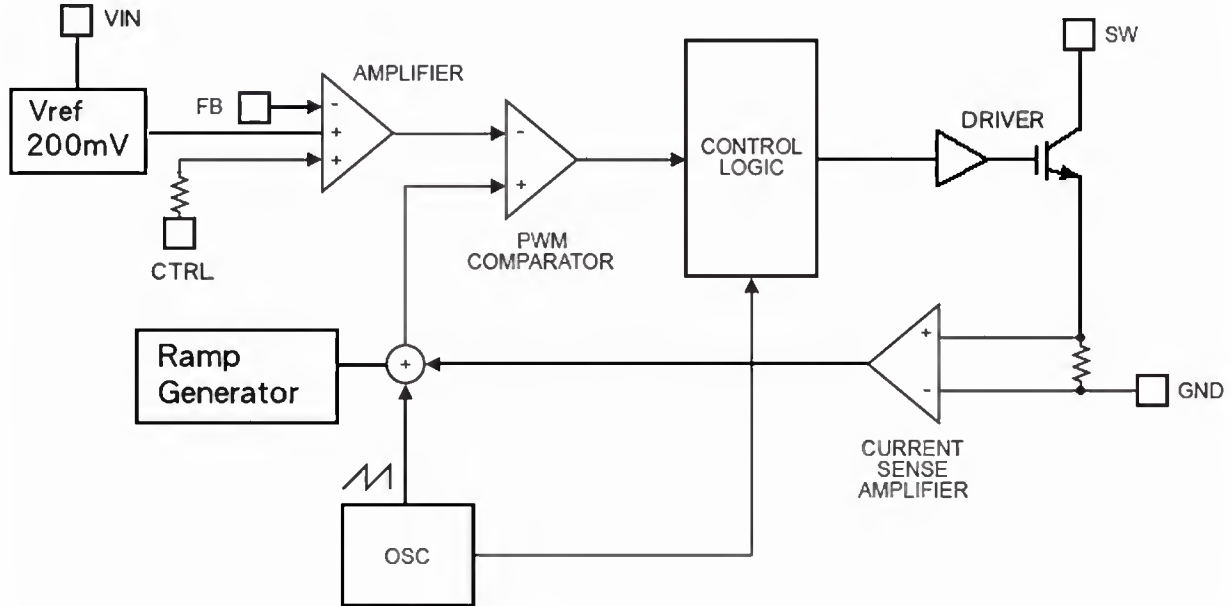
Function Parameter	Symbol	Test Conditions	Min	Typ	Max	Units
Input Voltage Range	$V_{IN}$		2.7	--	7	V
Quiescent Current (Not Switching)	$I_Q$	VFB = 0.3V	1.2	1.5	1.7	mA
Quiescent Current (Shutdown)		CTRL = 0V	--	0.3	1	µA
Feedback Voltage	$V_{FB}$	Iout=20mA, Vout=12.5V Circuit of Figure 1	180	200	220	mV
Switch Current Limit	$I_{CL}$	100% duty cycle	420	450	--	mA
	$I_{LIM}$	40% duty cycle	--	250	--	
FB Pin Bias Current	$I_B$	VFB=200mV	2	10	20	µA
Switching Frequency	$F_{RSW}$		680	700	720	KHz
Maximum Duty Cycle	$D_{TMX}$		--	--	85	%
Minimum Duty Cycle	$D_{TMN}$		20	--	25	%
Switch Vcesat	$V_{SAT}$	At Isw = 200mA	--	120	--	mV
Switch Leakage Current	$I_{LKG}$	Ctrl = 0.3V	--	1	--	µA
$V_{CTRL}$ for Full LED Current	$V_{CTL}$	Full On	--	1.7	1.8	V
		Full Off	--	0.2	0.3	V
CTRL Pin Bias Current	$I_{CTL}$	Ctrl = 2V	--	20	--	µA
Over Voltage Protection	OVP		--	30	--	V
Thermal Resistance	$\theta_{JA}$		--	220	--	°C/W

**Note:**

Absolute maximum ratings are limits beyond which damage to the device may occur.

The maximum allowable power dissipation is a function of maximum junction temperature,  $T_J(\text{max})$ , the junction to ambient thermal resistance,  $\theta_{JA}$ , and the ambient temperature. The maximum allowable power dissipation at any ambient temperature is calculated using:  $PD(\text{MAX}) = [T_J(\text{max}) - T_A] / \theta_{JA}$ . Exceeding the maximum allowable power dissipation will cause excessive die temperature. All limits at temperature extremes are guaranteed via correlation using standard statistical methods

**Functional Block**



**Pin Description**

Pin	Function	Description
1	SW	Switching Pin. This is the collector of the internal NPN power switch. Connect to inductor and diode. Minimize the metal trace area connected to this pin to reduce EMI.
2	Ground	Ground Pin. Connect directly to local ground plane.
3	Feedback	Feedback Pin. Reference voltage is 200mV. Connect LEDs and a resistor at this pin. LED current is determined by the resistance and CTRL voltage.
4	CTRL	Shutdown Pin and Dimming Control Pin. VCTRL > 1.8V generates full-scale LED current VCTRL < 0.4V chip is off Switching from 04V to 2.0V, PWM duty cycle controls the LED current
5	Input	Input Supply Pin. Bypass this pin with a capacitor as close to the device as possible

### Application Information

#### Operation

The TS1520 uses a constant frequency, current mode control scheme to regulate the output LED current. Its operation can be understood by referring to the block diagram in Figure 3. At the start of each oscillator cycle, a voltage proportional to the switch current is added to a ramp output and the resulting sum is fed into the positive terminal of the PWM comparator. When this voltage exceeds the level of the comparator negative input, the peak current has been reached, and the SR latch is reset and turns off the power switch. The voltage at the negative input of the comparator comes from the output of the error amplifier. The error amplifier sets the correct peak current level to keep the output in regulation. If the error amplifier's output increases, more current is delivered to the output; if it decreases, less current is delivered.

#### Inrush Current

The maximum switch current is limited to about 900mA by the chip. Typically, this large current will occur for about 40µs during start up. A larger  $C_{OUT}$  will increase the duration of high current. However, when  $V_{IN}$  is first connected, an even larger current can flow into  $C_{OUT}$ . This occurs when the SW pin is open circuit and the  $C_{OUT}$  voltage changes from 0V to  $V_{IN}$  in a few microseconds. Because the duration of this large current is short, it will usually not cause problems. If this current is not desirable, an external soft-start circuit can be added to significantly reduce this inrush current.

#### LED Current and Dimming Control

The maximum LED current set initially can be reduced by pulse width modulating the CTRL voltage from 0.4V to 1.8V. A better approach is to adjust the feedback voltage for dimming control. Either a DC level signal or a filtered PWM signal can be used to control the LED current as illustrated in Figure 1 and Figure 2 respectively. Using the above different scheme, the LED current can be controlled from 0% to 100% to its maximum value.

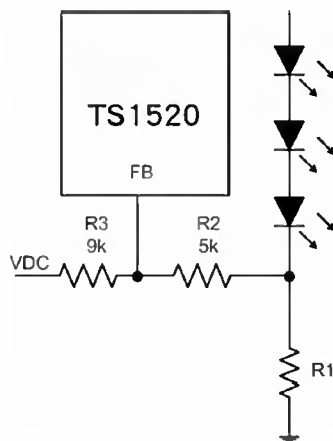


Figure 1. Dimming Control Using a DC Voltage

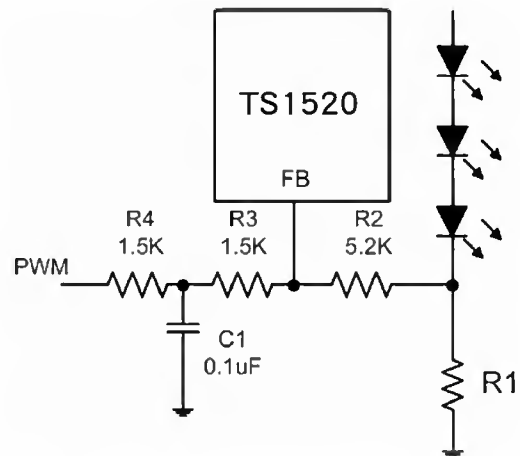


Figure 2. Dimming Control Using a Filtered PWM Signal (1kHz, 2Vp-p, duty 20%~80%)

#### Open Circuit Protection

The TS1520 has an internal open-circuit protection circuit. When the LEDs are disconnected from the circuit or fail open, the TS1520 will shutdown automatically until input condition changes to bring it out of the shutdown mode.

#### Inductor Selection

A 47µH inductor is recommended for most applications to drive more than 10 LEDs in serials and 33µH inductor is recommended for drive 30 LEDs in serials/parallel. Although small size and high efficiency are major concerns, the inductor should have low core losses at 1MHz and low DCR (copper wire resistance).

#### Diode Selection

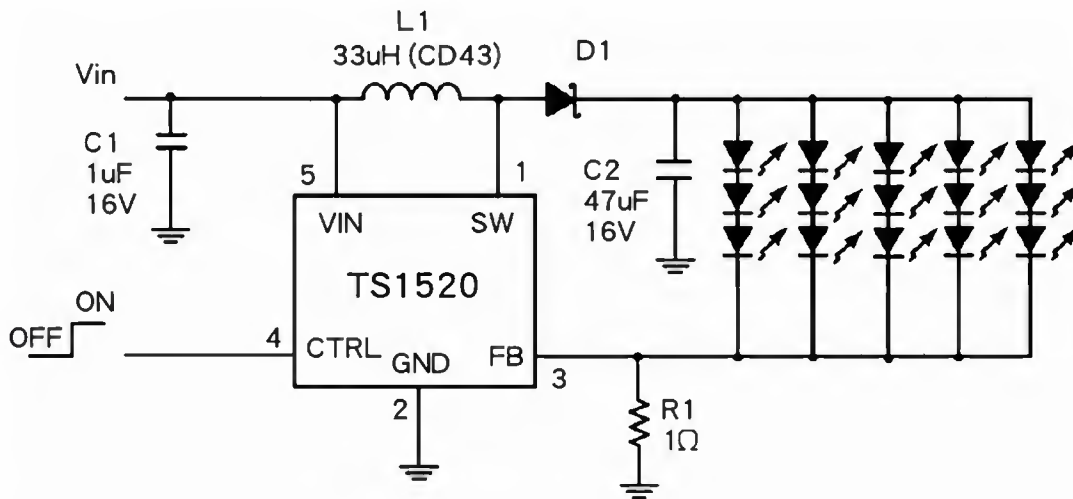
To maintain high efficiency, the average current rating of the Schottky diode should be large than the peak inductor current, IPK. Schottky diode with a low forward drop and fast switching speeds are ideal for increase efficiency in portable application. Choose a reverse breakdown of the Schottky diode large than the output voltage.

**Application Information (Continue)**

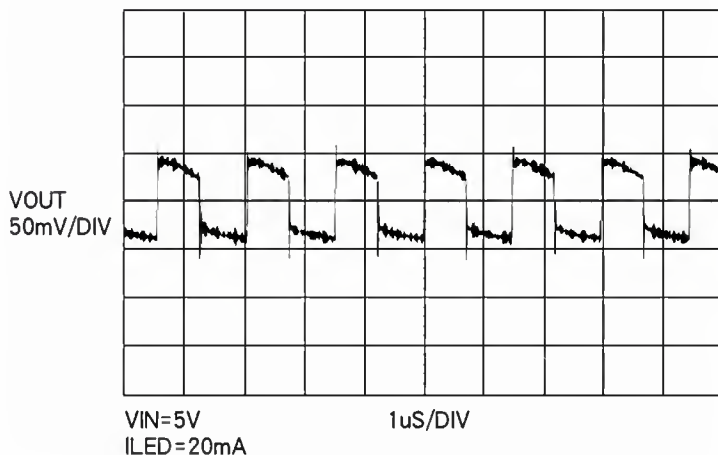
**Capacitor Selection**

Choose low ESR capacitors for the output to minimize output voltage ripple. Multilayer capacitors are a good choice for this as well. A 47uF capacitor is sufficient for most applications. For additional bypassing, a 100nF ceramic capacitor can be used to shunt high frequency ripple on the input. The input bypass capacitor  $C_{IN}$ , as shown in Figure 1, must be placed close to the IC. This will reduce copper trace resistance which affects input voltage ripple of the IC. For additional input voltage filtering, a 100nF bypass capacitor can be placed in parallel with  $C_{IN}$  to shunt any high frequency noise to ground. The output capacitor,  $C_{OUT}$ , should also be placed close to the IC. Any copper trace connections for the  $C_{OUT}$  capacitor can increase the series resistance, which directly effect output voltage ripple. The feedback network, resistor R2 should be kept close to the FB pin to minimize copper trace connections that can inject noise into the system. The ground connection for the feedback resistor network should connect directly to an analog ground plane. The analog ground plane should tie directly to the GND pin. If no analog ground plane is available, the ground connection for the feedback network should tie directly to the GND pin. Trace connections made to the inductor and Schottky diode should be minimized to reduce power dissipation and increase overall efficiency.

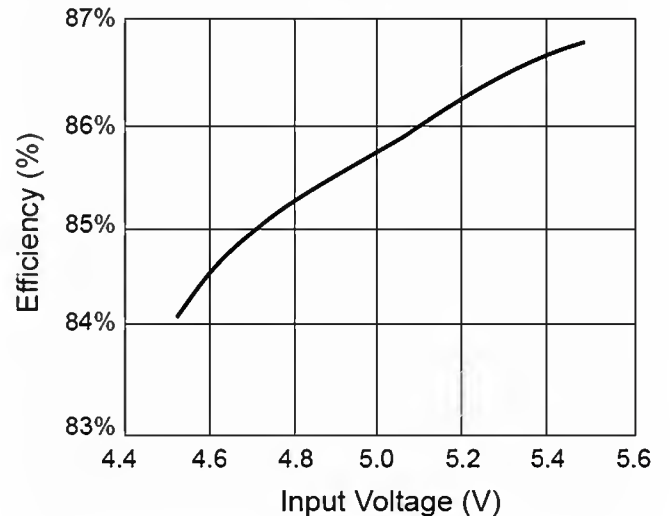
**Typical Performance Characteristics**



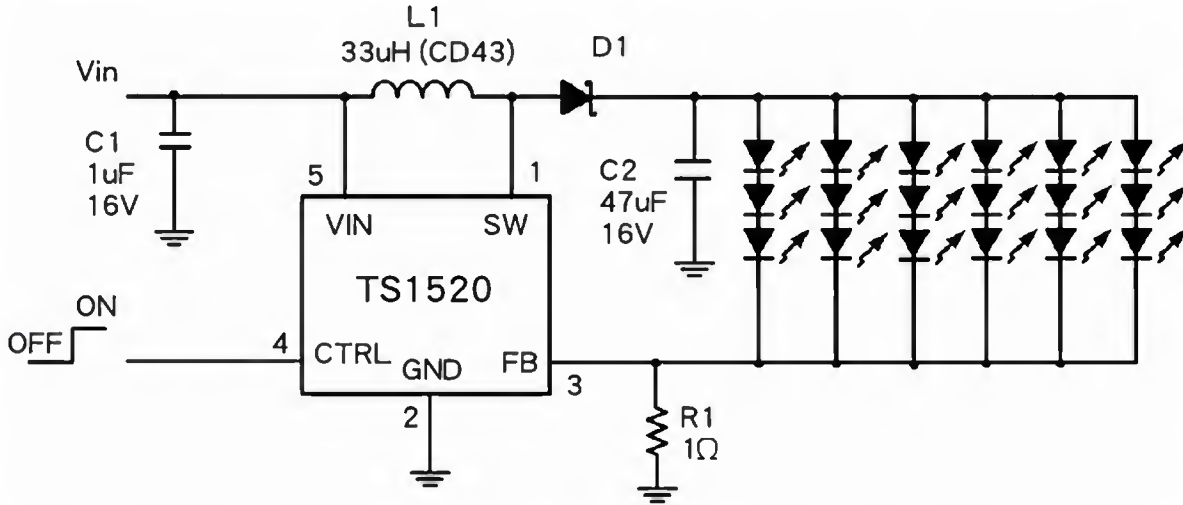
**3S5P Output Ripple**



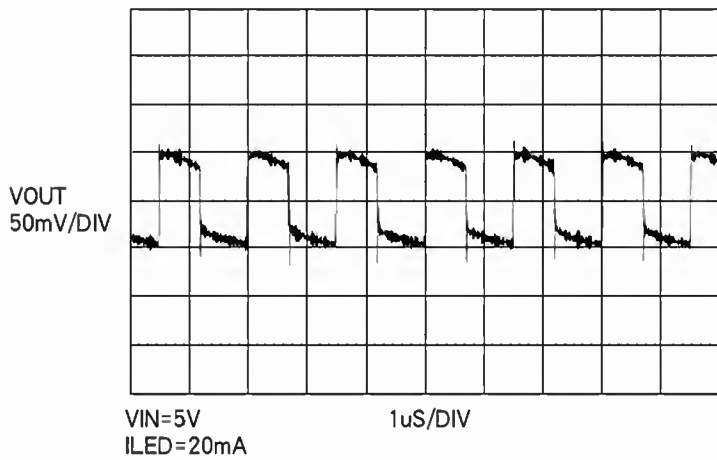
**Efficiency**



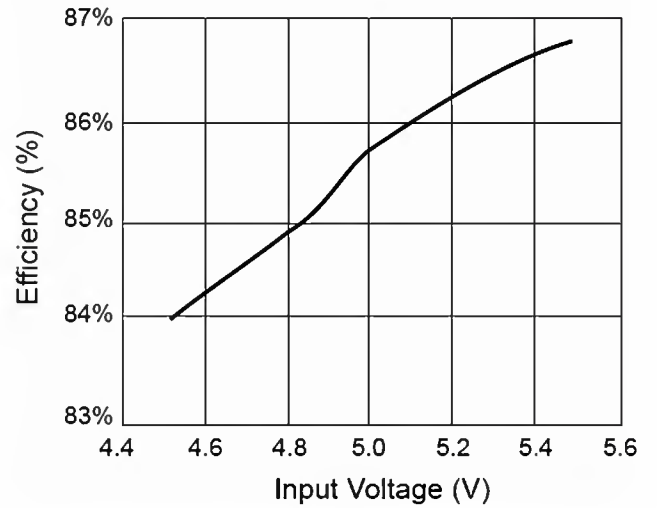
### Typical Performance Characteristics (Continue)



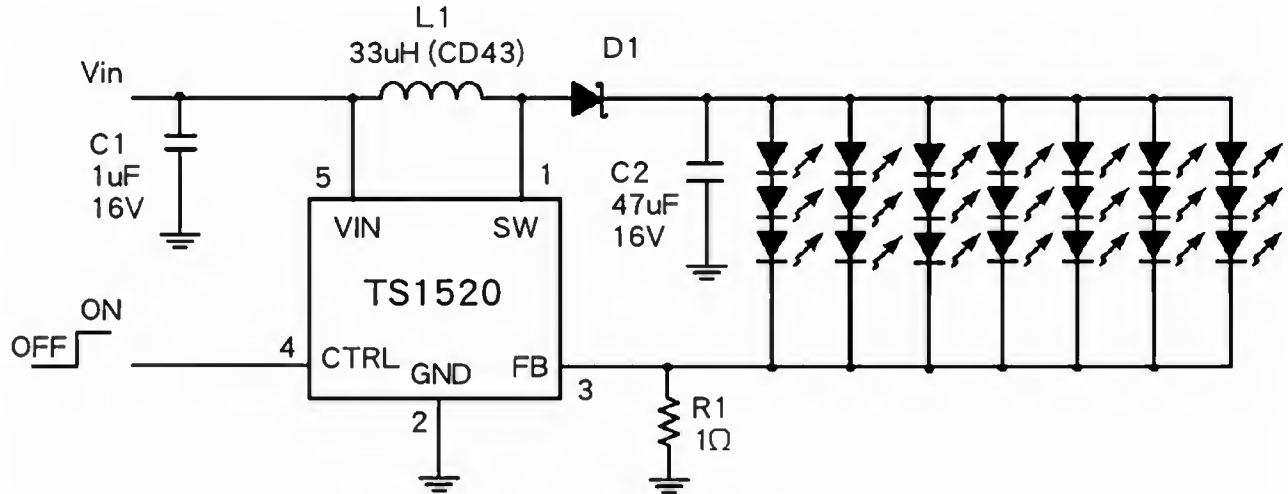
3S6P Output Ripple



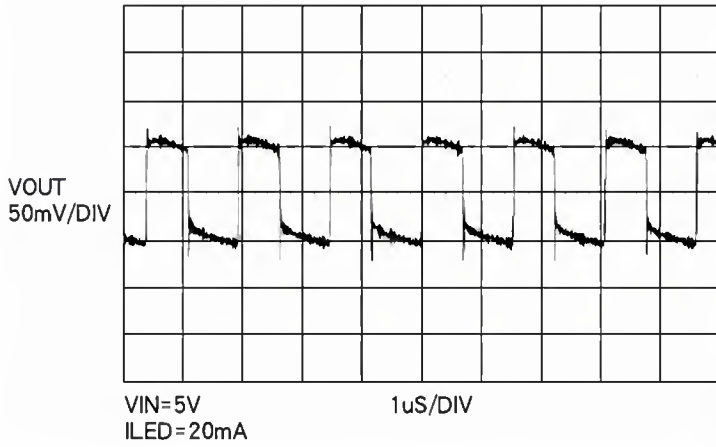
Efficiency



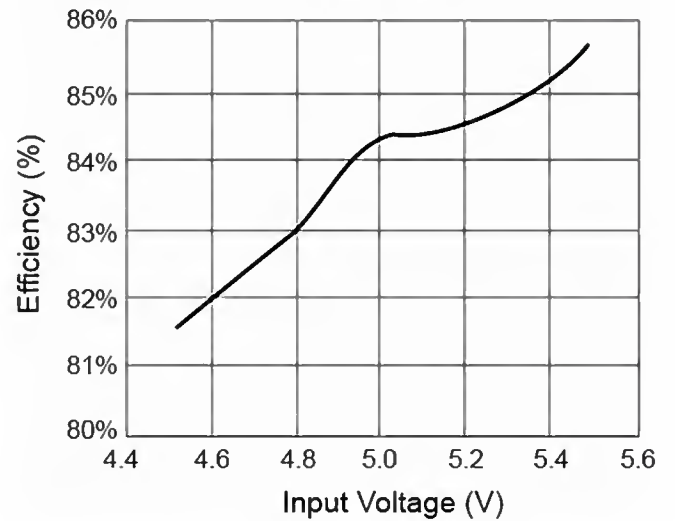
Typical Performance Characteristics (Continue)



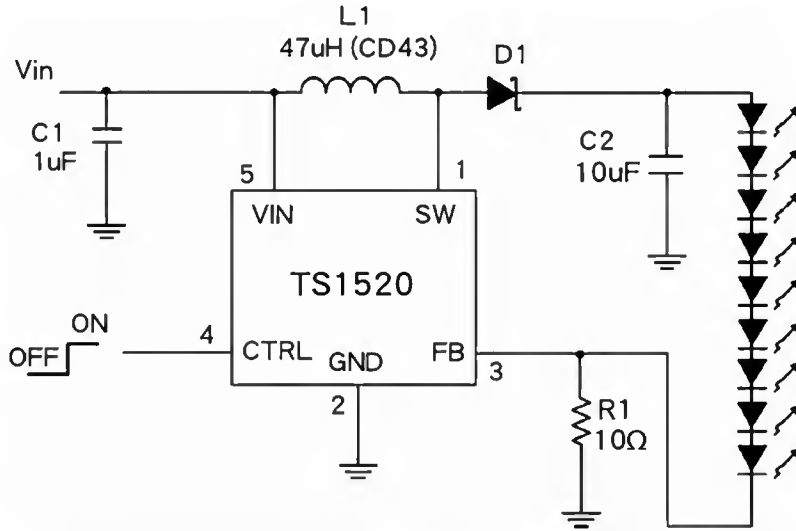
3S7P Output Ripple



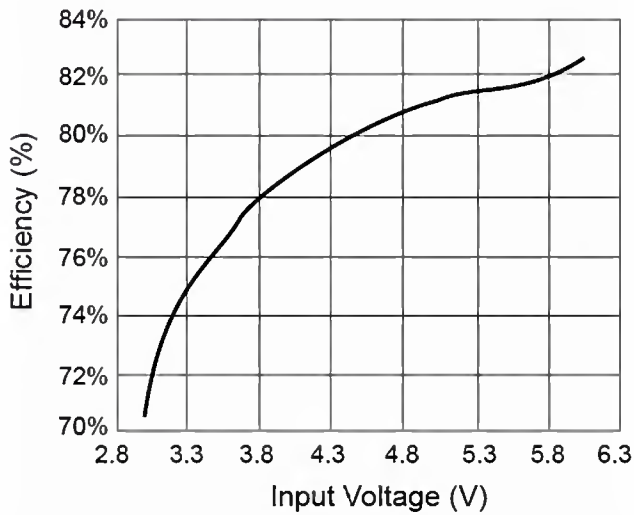
Efficiency



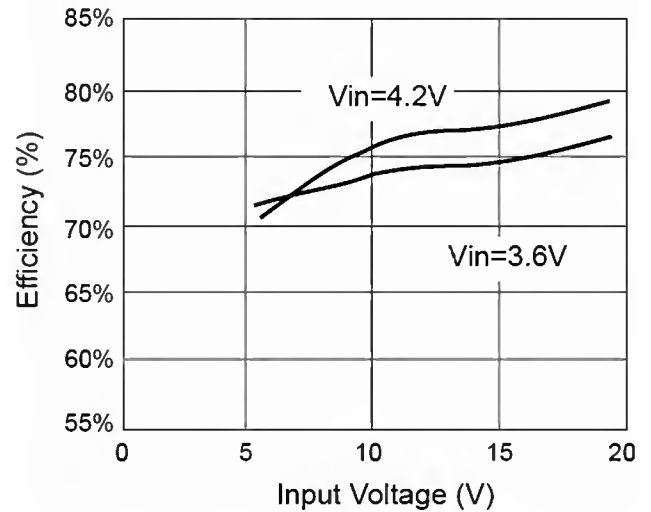
Typical Performance Characteristics (Continue)



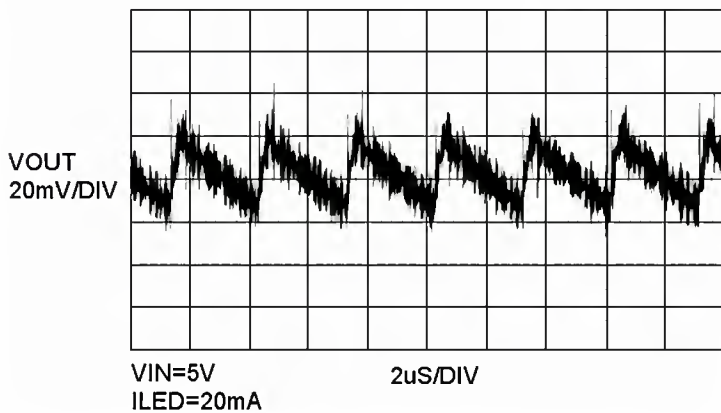
Efficiency



Efficiency

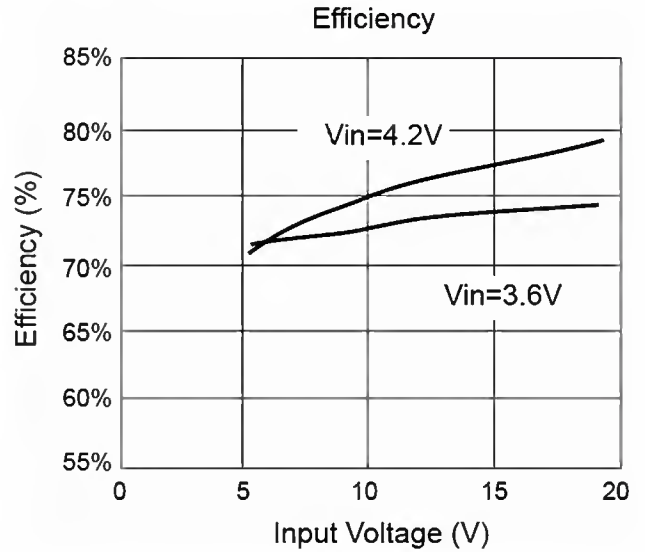
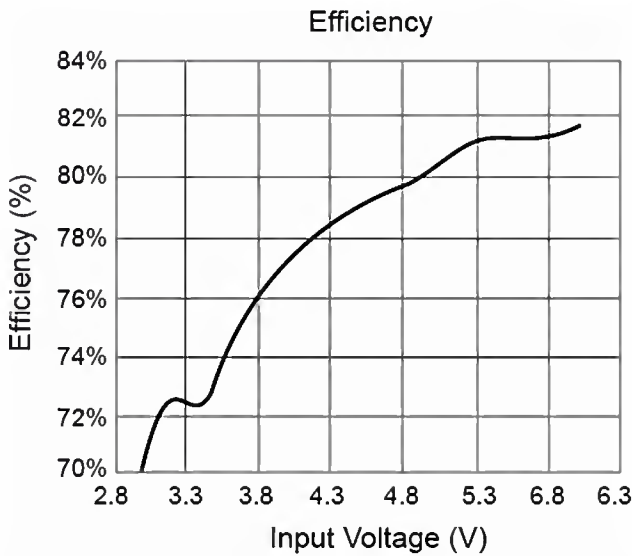
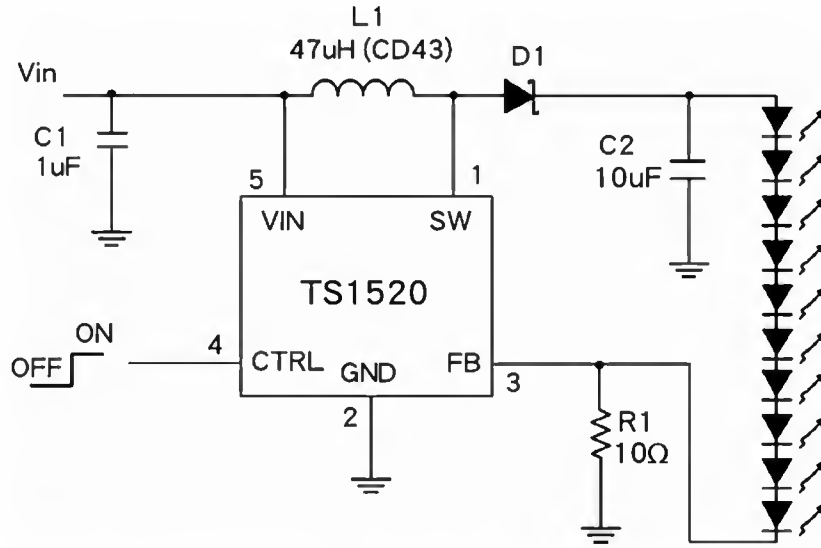


9S Output Ripple

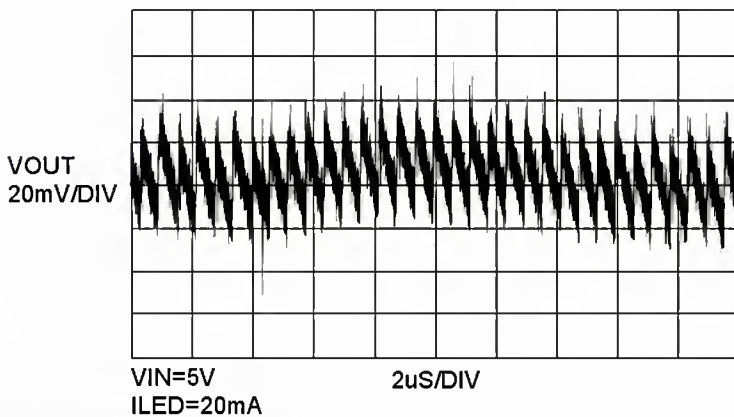




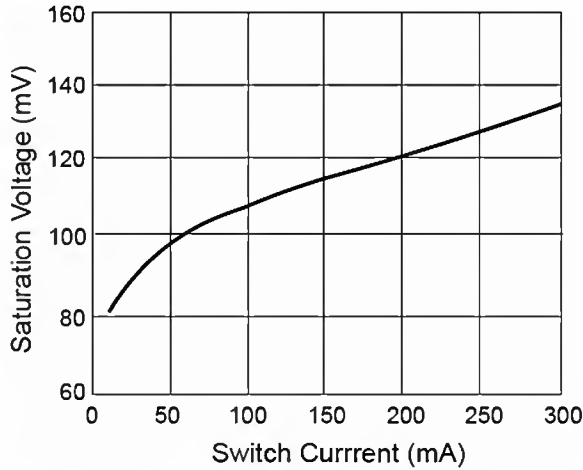
Typical Performance Characteristics (Continue)



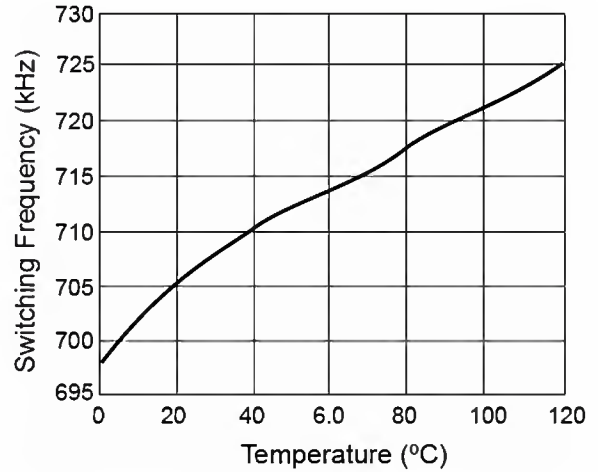
10S Output Ripple



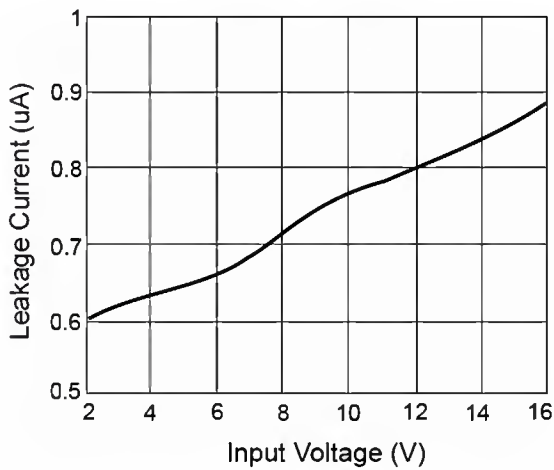
**Typical Performance Characteristics (Continue)**



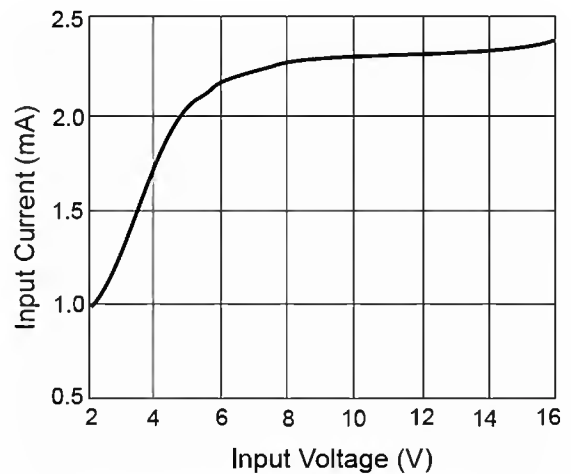
**Figure 1. Saturation Voltage vs. Switch Current**



**Figure 2. Switching Frequency vs. Temperature**

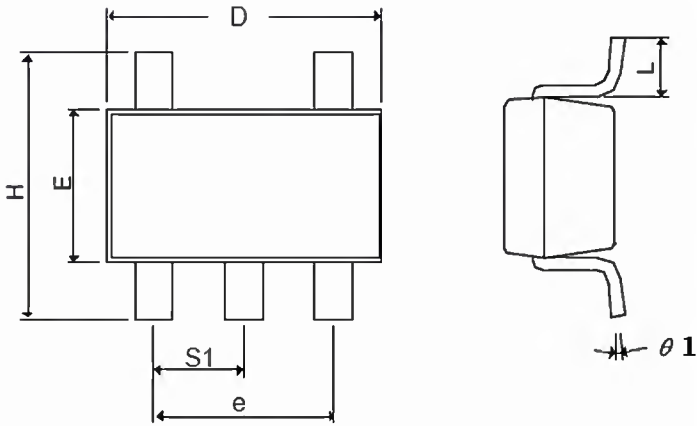


**Figure 3. Leakage Current vs. Input Voltage**



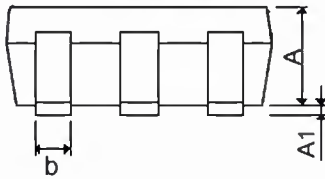
**Figure 4. Input Current vs. Input Voltage**

**SOT-25 Mechanical Drawing**



DIM	MILLIMETERS		INCHES	
	MIN	MAX	MIN	MAX.
A+A1	0.09	1.25	0.0354	0.0492
B	0.30	0.50	0.0118	0.0197
C	0.09	0.25	0.0035	0.0098
D	2.70	3.10	0.1063	0.1220
E	1.40	1.80	0.0551	0.0709
E	1.90 BSC		0.0748 BSC	
H	2.40	3.00	0.09449	0.1181
L	0.35 BSC		0.0138 BSC	
$\theta 1$	0°	10°	0°	10°
S1	0.95 BSC		0.0374 BSC	

**Front View**



### Notice

Specifications of the products displayed herein are subject to change without notice. TSC or anyone on its behalf, assumes no responsibility or liability for any errors or inaccuracies.

Information contained herein is intended to provide a product description only. No license, express or implied, to any intellectual property rights is granted by this document. Except as provided in TSC's terms and conditions of sale for such products, TSC assumes no liability whatsoever, and disclaims any express or implied warranty, relating to sale and/or use of TSC products including liability or warranties relating to fitness for a particular purpose, merchantability, or infringement of any patent, copyright, or other intellectual property right.

The products shown herein are not designed for use in medical, life-saving, or life-sustaining applications. Customers using or selling these products for use in such applications do so at their own risk and agree to fully indemnify TSC for any damages resulting from such improper use or sale.