



LinearDimensions
SEMICONDUCTOR

LND317

3-Terminal Adjustable Regulators

GENERAL DESCRIPTION

The LND317 is an adjustable 3-terminal positive-voltage regulator capable of supplying 1.5A over a differential voltage range of 3V to 40V. It is exceptionally easy to use and requires only two external resistors to set the output voltage. Both input and output regulation is better than standard fixed regulators.

In addition to higher performance than fixed regulators, the LND317 has full overload protection available only in integrated circuits. Included on the chip are current limit, thermal overload protection, and safe-area protection. All overload protection circuitry remains fully functional even if the adjustment terminal is disconnected. Normally, no capacitors are needed unless the device is situated far from the input filter capacitors in which case an input bypass is needed. An optional output capacitor can be added to improve transient response.

The primary applications of this device is that of a programmable output regulator, but by connecting a fixed resistor between adjustment terminal and the output terminal, the device can be used as a precision current regulator. Even though the regulator is floating and sees only the input-to-output differential voltage, use of these devices to regulate output voltages that would cause the maximum-rated differential voltage to be exceeded if the output became shorted to ground is not recommended.

FEATURES

- Output Voltage Range Adjustable from 1.2V to 37V
- Output Current Capability of 1.5A Max
- Input Regulation Typically 0.01% per Input-Volt Change
- Output Regulation Typically 0.1%
- Peak Output Current Constant Over Temperature Range of Regulator
- Popular 3-Lead TO-220 Package
- Ripple Rejection Typically 80 dB
- Direct Replacement for National LM317

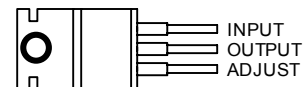

TO-220
(Top View)



ABSOLUTE MAXIMUM RATING

(unless otherwise noted)

	LND317	Unit
Input-to-Output differential voltage, $V_I - V_O$	40	V
Continuous total dissipation at 25°C free-air temperature	2	W
Continuous total dissipation at (or below) at 25°C case temperature	15	W
Operating free-air, case, or virtual junction temperature range	0 to 125	°C
Storage temperature range	-65 to 150	°C
Lead temperature 1.6mm (1/16 inch) from case for 10 seconds	260	°C

RECOMMENDED OPERATING CONDITIONS

	LND317		UNIT
	MIN	MAX	
Output current, I_O	10	1500	mA
Operating virtual junction temperature, T_J	0	125	°C

TYPICAL APPLICATION DATA

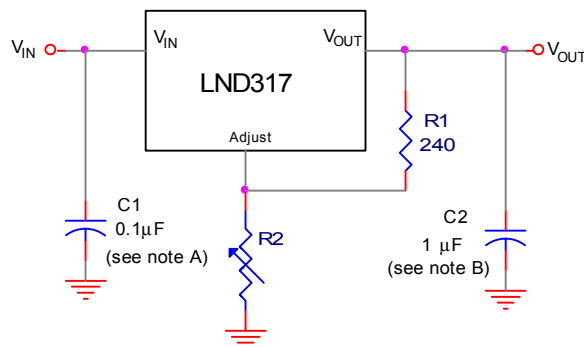

$$V_{OUT} = V_{REF} \left(1 + \frac{R2}{R1} \right) + I_{Adj} R2$$

Note A: Use of an Input Bypass Capacitor is recommended if regulator is far from filter capacitors

Note B: Use of an output capacitor improves transient response, but is optional.



ELECTRICAL CHARACTERISTICS

Over recommended ranges of operating virtual junction temperature (unless otherwise noted) (see Note 1)

PARAMETER	TEST CONDITIONS		LM317			UNIT
			MIN	TYP	MAX	
Input regulation(See Note 2)	$V_I - V_O = 3V$ to $40V$, (See Note 3)	$T_J = \text{MIN to MAX}$		0.01	0.04	% / V
		$I_O = 10\text{mA to } 1.5\text{A}$		0.02	0.07	
Ripple rejection	$V_O = 10\text{ V}$, $f = 120\text{ Hz}$			65		dB
	$V_O = 10\text{ V}$, $f = 120\text{ Hz}$ 10- μF capacitor between ADJ and ground		66	80		
Output Regulation	$I_O = 10\text{mA to } 1.5\text{ A}$, $T_J = 25^\circ\text{C}$, (See Note3)	$V_O \leq 5\text{V}$		5	25	mV
		$V_O > 5\text{V}$		0.1	0.5	%
	$I_O = 10\text{mA to } 1.5\text{A}$, (see note 3)	$V_O \leq 5\text{V}$		20	70	mV
		$V_O > 5\text{V}$		0.3	1.5	%
Output Voltage Change with temperature	$T_J = \text{MIN to MAX}$			1		%
Output voltage long-term drift(see note 4)	After 1000h at $T_J = \text{MAX}$ and $V_I - V_O = 40\text{V}$			0.3	1	%
Output noise voltage	$f = 10\text{Hz to } 10\text{kHz}$, $T_J = 25^\circ\text{C}$			0.003		%
Minimum output current to maintain regulation	$V_I - V_O = 40\text{V}$			3.5	10	mA
Peak output current	$V_I - V_O \leq 15\text{V}$		1.5	2.2		A
	$V_I - V_O \leq 40\text{V}$, $T_J = 25^\circ\text{C}$		0.15	0.4		
Adjustment terminal current				50	100	μA
Change in adjustment-terminal current	$V_I - V_O = 2.5\text{V to } 40\text{V}$, $I_O = 10\text{mA to } 1.5\text{A}$			0.2	5.0	μA
Reference voltage(output to ADJ)	$V_I - V_O = 3\text{V to } 40\text{V}$, $I_O = 10\text{mA to } 1.5\text{A}$, $P \leq 15\text{W}$		1.2	1.25	1.3	V

Unless otherwise noted, these specifications apply for the following test conditions: $V_I - V_O = 5\text{V}$ and $I_O = 0.5\text{A}$. For conditions shown as MIN or MAX, use the appropriate value specified under recommended operating conditions.

Notes:

- All characteristics are measured with a 0.1- μF capacitor across the input and a 1- μF capacitor across the output.
- Input regulation is expressed here as the percentage change in output voltage per 1-V change at the input.
- Pulse testing techniques are used to maintain the junction temperature as close to the ambient temperature as possible. Thermal effects must be taken into account separately.
- Since long-term drift cannot be measured on the individual devices prior to shipment, this specification is not intended to be a guarantee or warranty. It is an engineering estimate of the average drift to be expected from lot to lot.



TYPICAL APPLICATIONS

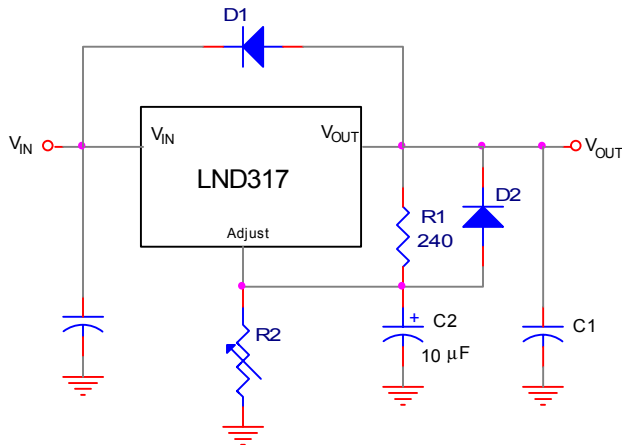

D1 protects against C1
D2 protects against C2

Regulator with Protection Diodes

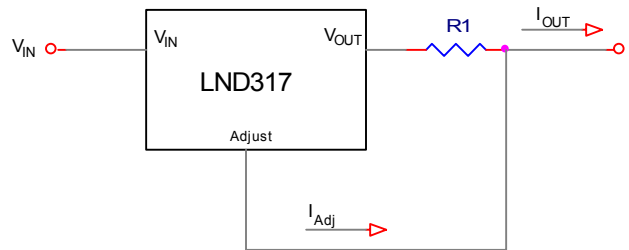

$$I_{OUT} = \left(\frac{V_{REF}}{R1} \right) + I_{Adj}$$

$$= \frac{1.25 V}{R1}$$

$$10 \text{ mA} \leq I_{OUT} \leq 1.5 \text{ A}$$

Current Regulator

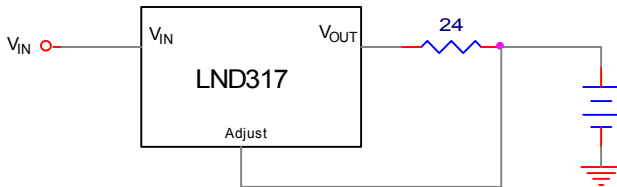

50 mA Constant Current Battery Charger