

2W High Linearity and High Efficiency GaAs Power FETs

FEATURES

- 2W Typical Power at 6 GHz
- Linear Power Gain: $G_L = 12$ dB Typical at 6 GHz
- High Linearity: $IP3 = 43$ dBm Typical at 6 GHz
- Via Holes Source Ground
- Suitable for High Reliability Application
- Breakdown Voltage: $BV_{DGO} \geq 15$ V
- $L_g = 0.35$ μ m, $W_g = 5$ mm
- High Power Added Efficiency: $PAE \geq 43$ % for Class A Operation
- $L_g = 0.35$ μ m, $W_g = 5$ mm
- Tight V_p ranges control
- High RF input power handling capability
- 100 % DC Tested

PHOTO ENLARGEMENT

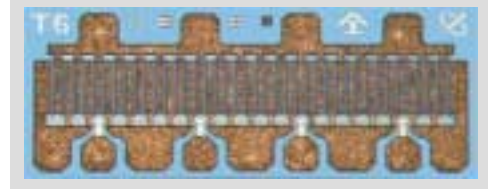

DESCRIPTION

The TC1601 is a Pseudomorphic High Electron Mobility Transistor (PHEMT) GaAs Power FET, Which has high linearity and high Power Added Efficiency. The device is processed with a propriety via-hole process, which provides low thermal resistance and low inductance. The short gate length enables the device to be used in circuits up to 20 GHz. All devices are 100 % DC tested to assure consistent quality. Bond pads are gold plated for either thermo-compression or thermo-sonic wire bonding. Backside gold plating is compatible with standard AuSn die-attach. Typical applications include commercial and military high performance power amplifier.

ELECTRICAL SPECIFICATIONS ($T_A=25$ °C)

Symbol	Conditions	MIN	TYP	MAX	UNIT
P_{1dB}	Output Power at 1dB Gain Compression Point, $f = 6$ GHz $V_{DS} = 8$ V, $I_{DS} = 500$ mA	32.5	33		dBm
G_L	Linear Power Gain, $f = 6$ GHz $V_{DS} = 8$ V, $I_{DS} = 500$ mA	11	12		dB
$IP3$	Intercept Point of the 3 rd -order Intermodulation, $f = 6$ GHz $V_{DS} = 8$ V, $I_{DS} = 500$ mA, $*P_{SCL} = 20$ dBm		43		dBm
PAE	Power Added Efficiency at 1dB Compression Power, $f = 6$ GHz		43		%
I_{DSS}	Saturated Drain-Source Current at $V_{DS} = 2$ V, $V_{GS} = 0$ V		1.2		A
g_m	Transconductance at $V_{DS} = 2$ V, $V_{GS} = 0$ V		850		mS
V_P	Pinch-off Voltage at $V_{DS} = 2$ V, $I_D = 10$ mA		-1.7**		Volts
BV_{DGO}	Drain-Gate Breakdown Voltage at $I_{DGO} = 2.5$ mA	15	18		Volts
R_{th}	Thermal Resistance		6		°C/W

Note:

* P_{SCL} : Output Power of Single Carrier Level.

**For the tight control of the pinch-off voltage . TC1601's are divided into 3 groups:

(1) **TC1601P1519** : $V_p = -1.5V$ to $-1.9V$ (2) **TC1601P1620** : $V_p = -1.6V$ to $-2.0V$

(3) **TC1601P1721** : $V_p = -1.7V$ to $-2.1V$ In addition, the customers may specify their requirements.

ABSOLUTE MAXIMUM RATINGS (T_A=25 °C) RECOMMENDED OPERATING CONDITION

Symbol	Parameter	Rating
V _{DS}	Drain-Source Voltage	12 V
V _{GS}	Gate-Source Voltage	-5 V
I _D	Drain Current	1.2 A
P _T	Continuous Dissipation	7.7 W
T _{CH}	Channel Temperature	175 °C
T _{STG}	Storage Temperature	- 65 °C to +175 °C

Symbol	Parameter	Rating
V _{DS}	Drain to Source Voltage	8 V
I _D	Drain Current	500 mA

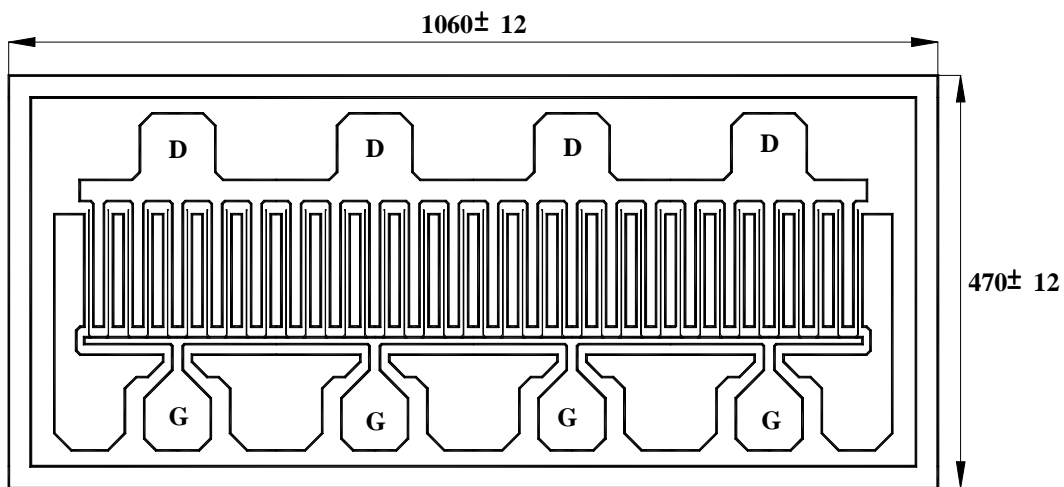
CHIP DIMENSIONS

Units: Micrometers
Chip Thickness: 50
Gate Pad: 76.0 x 59.5
Drain Pad: 86.0 x 76.0

TYPICAL SCATTERING PARAMETER ($V_{DS} = 8\text{ V}$, $I_{DS} = 500\text{ mA}$)

FREQUENCY (GHz)	S11		S21		S12		S22	
	MAG	ANG	MAG	ANG	MAG	ANG	MAG	ANG
0.05	0.99574	-28.397	37.17	165.02	0.0078177	75.215	0.16856	-68.237
0.1	0.98587	-53.672	34.038	151.75	0.014318	62.138	0.26521	-97.116
0.2	0.96544	-90.648	26.53	132.47	0.022319	43.232	0.3948	-125.14
0.3	0.95271	-113.2	20.626	120.66	0.026028	31.814	0.45652	-139.36
0.4	0.94572	-127.35	16.544	113.1	0.027836	24.636	0.48709	-147.65
0.5	0.94174	-136.8	13.697	107.88	0.028806	19.799	0.50388	-152.91
0.6	0.93933	-143.46	11.638	104.03	0.029372	16.331	0.51405	-156.46
0.7	0.93779	-148.39	10.095	101.03	0.029723	13.717	0.52079	-158.96
0.8	0.93676	-152.16	8.901	98.595	0.029952	11.664	0.5256	-160.78
0.9	0.93605	-155.14	7.9524	96.548	0.030104	10.001	0.52927	-162.13
1	0.93554	-157.54	7.1819	94.779	0.030208	8.6153	0.53225	-163.14
1.1	0.93518	-159.53	6.5443	93.216	0.030278	7.4363	0.53479	-163.92
1.2	0.93491	-161.19	6.0082	91.811	0.030325	6.4143	0.53706	-164.51
1.3	0.93472	-162.59	5.5514	90.528	0.030354	5.5145	0.53916	-164.95
1.4	0.93458	-163.81	5.1576	89.341	0.03037	4.7118	0.54115	-165.29
1.5	0.93448	-164.86	4.8147	88.233	0.030375	3.9874	0.54309	-165.54
1.6	0.93441	-165.78	4.5133	87.19	0.030371	3.3272	0.545	-165.72
1.7	0.93437	-166.6	4.2465	86.2	0.030361	2.7205	0.54691	-165.84
1.8	0.93435	-167.32	4.0085	85.254	0.030345	2.1586	0.54882	-165.92
1.9	0.93435	-167.97	3.7949	84.347	0.030324	1.635	0.55076	-165.96
2	0.93436	-168.55	3.6022	83.473	0.030298	1.1442	0.55273	-165.97
3	0.93501	-172.24	2.3682	75.87	0.02987	-2.6275	0.57477	-165.17
4	0.93615	-174.09	1.7392	69.39	0.02924	-5.282	0.60072	-164.02
5	0.93754	-175.19	1.3557	63.538	0.02848	-7.316	0.62891	-163.13
6	0.93905	-175.95	1.0969	58.161	0.02764	-8.8846	0.65763	-162.62
7	0.9406	-176.5	0.91049	53.193	0.02676	-10.055	0.68559	-162.45
8	0.94213	-176.94	0.77029	48.597	0.02587	-10.869	0.71196	-162.56
9	0.94358	-177.29	0.66149	44.343	0.02499	-11.358	0.73629	-162.88
10	0.94495	-177.6	0.57506	40.401	0.02415	-11.554	0.7584	-163.33
11	0.94621	-177.87	0.50515	36.746	0.02334	-11.487	0.77829	-163.88
12	0.94736	-178.11	0.44776	33.3519	0.02259	-11.185	0.79607	-164.47
13	0.94841	-178.34	0.40006	30.196	0.0219	-10.675	0.81191	-165.1
14	0.94935	-178.54	0.36001	27.254	0.02126	-9.985	0.82598	-165.74
15	0.95019	-178.73	0.32605	24.506	0.02068	-9.1377	0.83848	-166.37
16	0.95096	-178.91	0.29703	21.933	0.02015	-8.1559	0.84959	-167
17	0.95164	-179.08	0.27204	19.5189	0.01968	-7.06	0.85948	-167.6
18	0.95225	-179.23	0.25036	17.248	0.01926	-5.8689	0.8683	-168.19

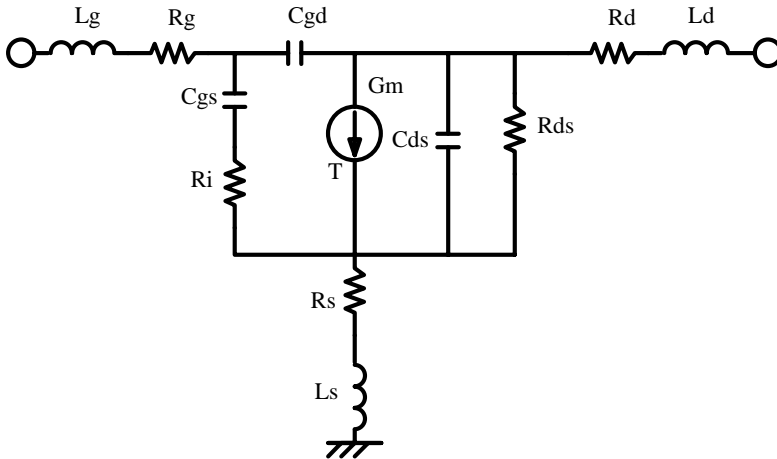
* The data does not include gate, drain and source bond wires.

SMALL SIGNAL MODEL, $V_{DS} = 8\text{ V}$, $I_{DS} = 500\text{ mA}$
SCHEMATI

FET Parameter

Lg = 0.0035 nH	Rs = 0.23 Ohm
Rg = 0.3 Ohm	Ls = 0.0013 nH
Cgs = 7.84 pF	Cds = 0.864 pF
Ri = 0.487 Ohm	Rds = 51 Ohm
Cgd = 0.44 pF	Rd = 0.402 Ohm
Gm = 840 mS	Ld = 0.006 nH
T = 3.9 psec	