

## G5JLM2931

### 100mA Low Dropout Adjustable Voltage Regulator

#### Description

The G5JLM2931 positive voltage regulator features a very low quiescent current of 1mA or less when supplying 10mA loads. This unique characteristic and the extremely low input-output differential required for proper regulation (0.2V for output current of 10mA) make the G5JLM2931 the ideal regulator for standby power system. Applications include memory standby circuits, COMS and other low power processor power supplies as well as systems demanding as much as 100mA of output current.

Designed originally for automotive applications, the G5JLM2931 and all regulated circuitry are protected from reverse battery installations or 2 battery jumps. During line transients, such as a load dump(60V) when the input voltage to the regulator can momentarily exceed the specified maximum operating voltage, the regulator will automatically shut down to protect both internal circuits and the load. The G5JLM2931 cannot be harmed by temporary mirror-image insertion. Familiar regulator features such as short circuit and thermal overload protection are also provided.

#### Features

- Input-to-Output Voltage Differential of Less Than 0.6 V at 100mA
- 60V Load Dump Protection
- -50 V Reverse Transient Protection
- Internal Current Limiting with Thermal Shutdown
- Temporary Mirror-Image Protection

#### Package Dimensions

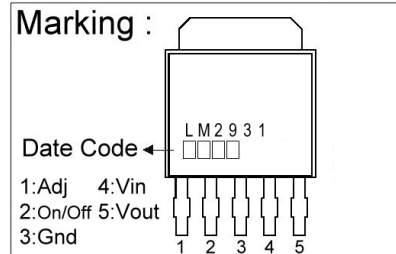
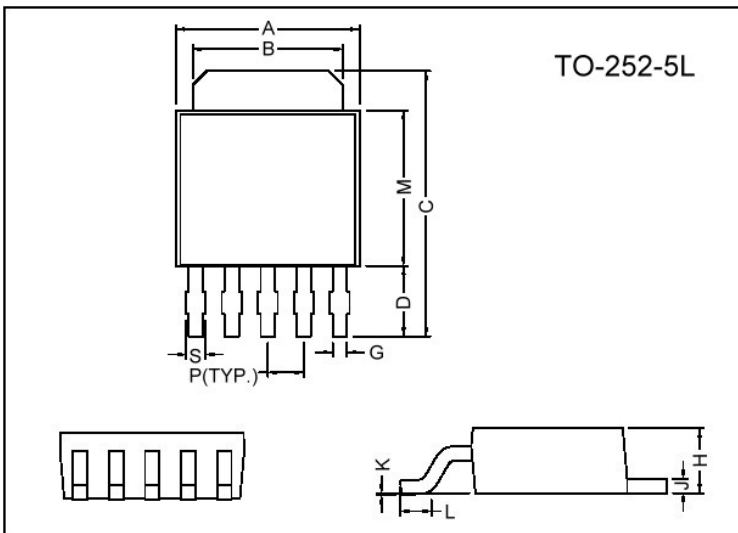

REF.	Millimeter		REF.	Millimeter	
	Min.	Max.		Min.	Max.
A	6.35	6.73	G	0.45	0.60
B	5.21	5.46	H	2.20	2.40
C	9.40	10.20	J	0.46	0.58
D	2.40	3.00	K	0	0.15
P	1.27 REF.		L	0.90	1.50
S	0.50	0.80	M	5.40	5.59

#### Typical Applications

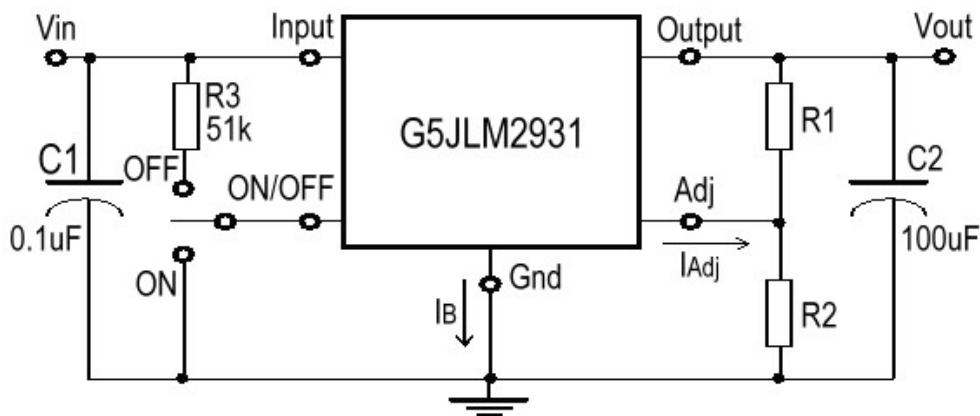

$$V_{out} = V_{ref} * (1 + R2/R1) + I_{Adj} * R2$$

## Absolute Maximum Ratings

Parameter	Symbol	Ratings	Unit
Input Voltage	$V_i$	-15 ~ 40	V
Input Voltage $t \leq 100\text{ms}$	$V_i(t)$	-50 ~ 60	V
Output Current	$I_o$	100	mA
Storage Temperature	TSTG	-60 ~ +150	°C
Junction Temperature	TJ	-40 ~ +125	°C
Resistance Junction-Ambient	R $\theta$ JA	102	°C/W

## Electrical Characteristics

$V_{IN}=14\text{V}$ ,  $V_{OUT}=3\text{V}$ ,  $I_o=10\text{mA}$ ,  $T_J=25^\circ\text{C}$ ,  $C_i=0.1\mu\text{F}$ ,  $C_o=100\mu\text{F}$ ,  $R_1=27\text{k}$  (unless otherwise specified)

Parameter	Symbol	Conditions	Min	Typ	Max	Unit
Reference voltage	$V_{REF}$	$I_o=10\text{mA}$	1.14	1.20	12.6	V
		$I_o \leq 100\text{mA}$ , $-40^\circ\text{C} \leq T_J \leq 125^\circ\text{C}$ Measure from $V_{OUT}$ to Adj Pin	1.08		1.32	V
Output voltage	$V_{OUT}$		3		24	V
Line regulation	RegLine	$V_{OUT}+0.6\text{V} \leq V_{IN} \leq 26\text{V}$	-	-	1.5	mV/V
Load regulation	RegLoad	$5\text{mA} \leq I_o \leq 100\text{mA}$	-	-	1.0	%
Consumption current	$I_B$	$I_o=10\text{mA}$	-	-	1.0	mA
		$I_o=100\text{mA}$	-	6	-	
		Output is "off" ( $V_{th(OI)}=2.5\text{V}$ )	-	-	1.0	
Adjustment current	$I_{Adj}$		-	0.2	-	uA
Dropout voltage	$V_{ds}$	$I_o=10\text{mA}$	-	-	0.2	V
		$I_o=100\text{mA}$	-	-	0.6	
Output Impedance	$Z_O$	$\Delta I_o=1\text{mA}$ , $f=10\text{Hz} \sim 100\text{kHz}$	-	40	-	m $\Omega$ /V
Noise voltage on output	$V_n$	$f=10\text{Hz} \sim 100\text{kHz}$	-	140	-	mV/V
Pulse-smoothing ratio	RR	$f=120\text{Hz}$	0.1	-	-	%/V
Temporary unstability of output voltage	S		-	0.4	-	%/1000hr
Maximum input voltage threshold	$V_{th(OV)}$		26	-	40	V
Output voltage at negative input voltage	- $V_O$	$V_{IN}=-15\text{V}$	-0.3	-	-	V
Voltage threshold of disconnection output	$V_{th(OI)}$	Output is "ON"	-	-	1.9	V
		Output is "OFF"	2.5	-	-	
Disconnection output current	$I_{th(OI)}$	$V_{th(OI)}=2.5\text{V}$	-	-	50	uA

## Definition of Terms

**Dropout Voltage:** The input-output voltage differential at which the circuit ceases to regulate against further reduction in input voltage. Measured when the output voltage has dropped 100mV from the nominal value obtained at 14V input, dropout voltage is dependent upon load current and junction temperature.

**Input Voltage:** The DC voltage applied to the input terminals with respect to ground.

**Input-Output Differential:** The voltage difference between the unregulated input voltage and the regulated output voltage for which the regulator will operate.

**Line Regulation:** The change in output voltage for a change in the input voltage. The measurement is made under conditions of low dissipation or by using pulse techniques such that the average chip temperature is not significantly affected.

**Load Regulation:** The change in output voltage for a change in load current at constant chip temperature.

**Long Term Stability:** Output voltage stability under accelerated life-test conditions after 1000 hours with maximum rate voltage and junction temperature.

**Output Noise Voltage:** The rms AC voltage at the output, with constant load and no input ripple, measured over a specified frequency range.

**Quiescent Current:** That part of the positive input current that does not contribute to the positive load current. The regulator ground lead current.

**Ripple Rejection:** The ratio of the peak-to-peak input ripple voltage to the peak-to-peak output ripple voltage at a specified frequency.

## Typical Performance Characteristics

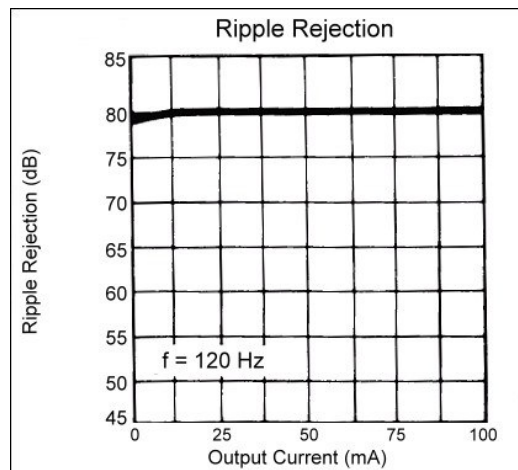
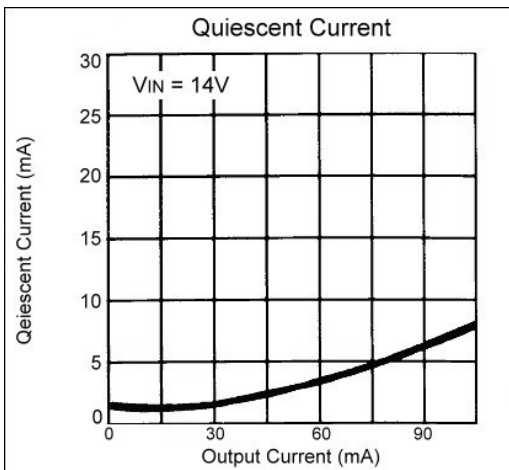
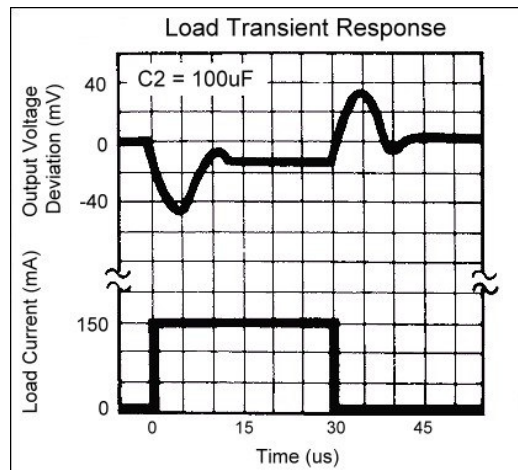
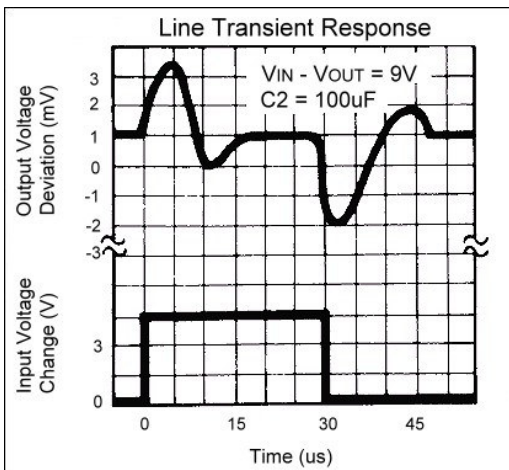
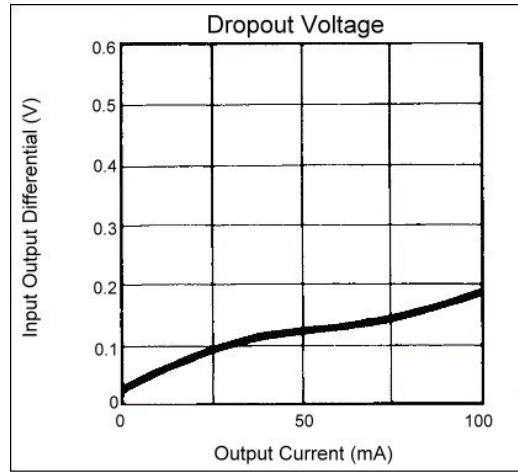
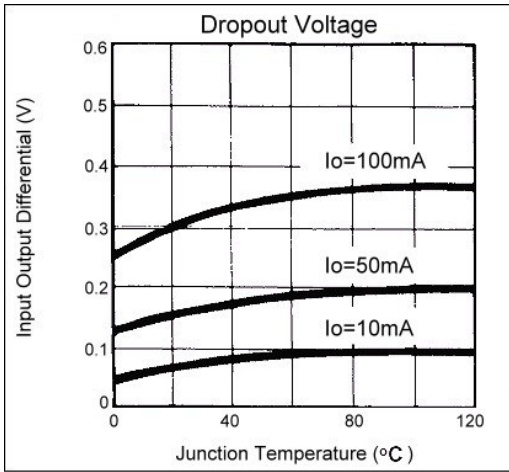

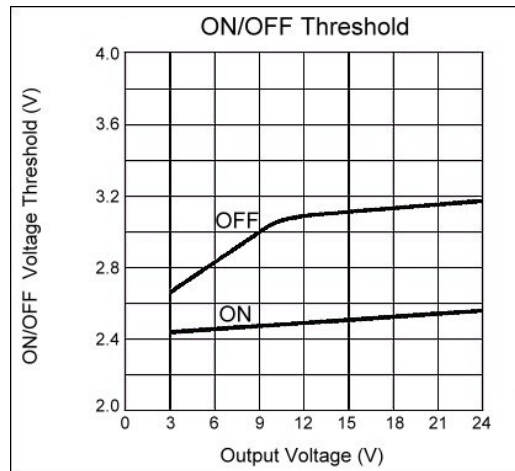
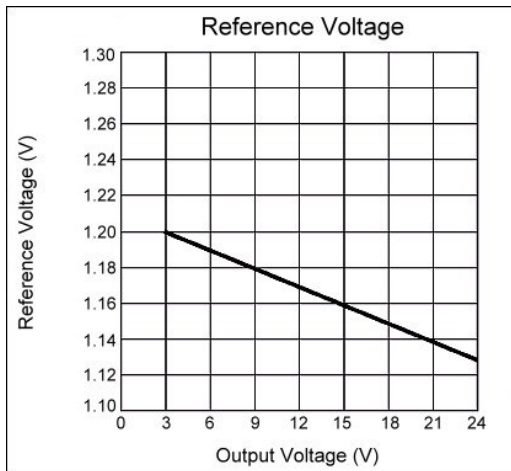

**Important Notice:**

- All rights are reserved. Reproduction in whole or in part is prohibited without the prior written approval of GTM.
- GTM reserves the right to make changes to its products without notice.
- GTM semiconductor products are not warranted to be suitable for use in life-support Applications, or systems.
- GTM assumes no liability for any consequence of customer product design, infringement of patents, or application assistance.

**Head Office And Factory:**

- **Taiwan:** No. 17-1 Tatung Rd. Fu Kou Hsin-Chu Industrial Park, Hsin-Chu, Taiwan, R. O. C.
- TEL : 886-3-597-7061 FAX : 886-3-597-9220, 597-0785
- **China:** (201203) No.255, Jang-Jiang Tsai-Lueng RD. , Pu-Dung-Hsin District, Shang-Hai City, China
- TEL : 86-21-5895-7671 ~ 4 FAX : 86-21-38950165