

AKD4711-A

AK4711 Evaluation Board Rev.1

GENERAL DESCRIPTION

AKD4711 is an evaluation board for quickly evaluating the AK4711, Single SCART Driver. Evaluation requires audio/video analog analyzers/generators and a power supply.

■ Ordering guide

AKD4711-A --- AK4711 Evaluation Board
(Control software and USB cable are packed with this.)

FUNCTION

- **RCA connectors for analog audio output**
- **XLR connectors for analog audio input**
- **RCA connectors for SD/HD video input/output**
- **USB connector for serial control interface**

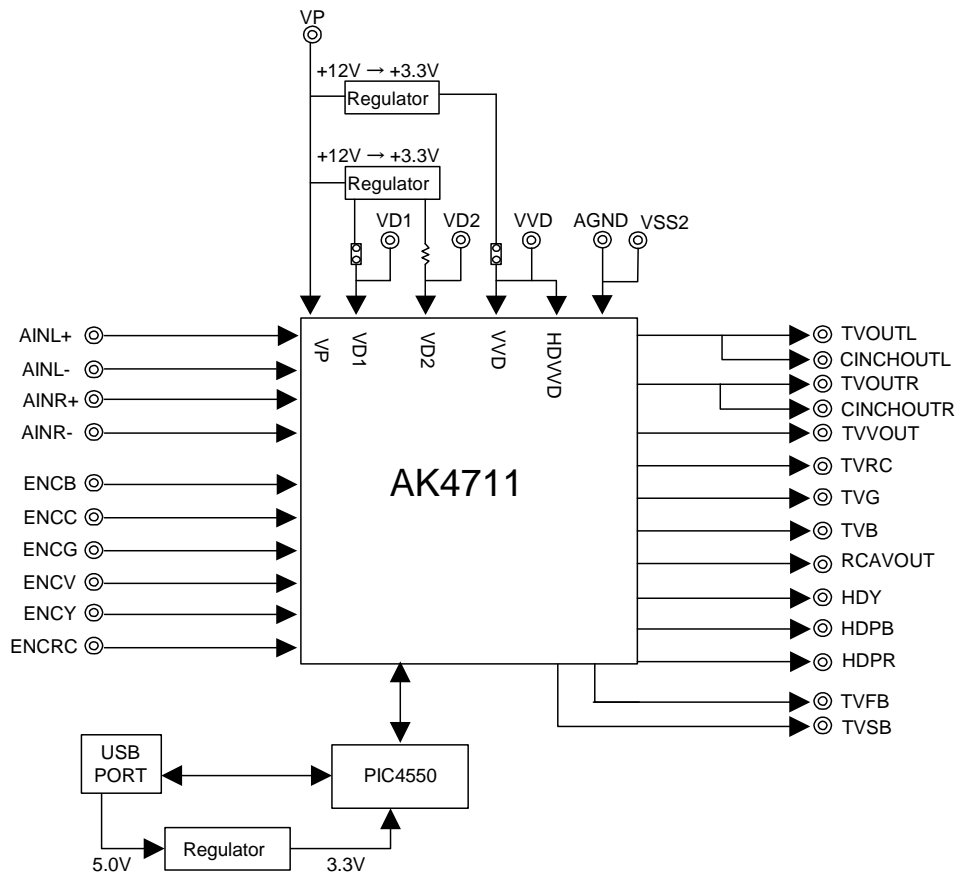

figure 1. AKD4711 Block Diagram

※Circuit diagram and PCB layout are attached at the end of this manual.

EVALUATION BOARD MANUAL

■ Operation sequence

1) Set up the power supply lines.

Name of Jack	Color of Jack	Voltage	Used for	Comment and attention	Default of Jack
VP	Yellow	+10.8~+13.2V	VP of AK4711	Should be always connected	+12V
VD1	Red	+3.13~+3.47	VD1 of AK4711	Should be connected when jp5 (VD1_SEL) is set to REG side. Should be open when JP5 (VD1_SEL) is set to VD1 side.	open
VD2	Red	+3.13~+3.47V	VD2 of AK4711	Should be connected when R 51(VD2_SEL) is set to REG side. Should be open when R51 (VD2_SEL) is set to VD2 side.	open
VVD	Red	+3.13~+3.47V	VVD of AK4711 HDVVD of AK4711	Should be connected when JP6 (VVD_SEL) is set to REG side. Should be open when JP6(VVD_SEL) is set to VVD side.	open
D3.3V	Red	+3.13 ~ 3.47V	Power supply of logic	Should be connected when JP7 (VCC_SEL) is set to REG side. Should be open when JP7 (VCC_SEL) is set to D3.3V side.	open
AGND	Black	0V	Analog Ground	Should be always connected	0V
VSS2	Black	0V	Analog Ground	Should be always connected	open
DGND	Black	0V	Digital Ground	Should be connected when JP4 (GND_SEL) is set to AGND side. Should be open when JP4 (GND_SEL) is set to DGND side.	open

Table 1. Power supply lines

Each supply line should be distributed from the power supply unit.

2) Set-up jumper pins. (See the followings.)

3) Power on.

The AK4711 should be reset once bringing SW1 “L” upon power-up.

■ Jumper pins set up

[JP1] (GND): AINL- pin input select

OPEN: J5 (AINL): 3pin <Default>

SHORT: GND (Not to use)

[JP2] (GND): AINR- pin input select

OPEN: J13 (AINR): 3pin <Default>

SHORT: GND (Not to use)

[JP3] Not to use

[JP4] (GND): Analog ground and Digital ground

OPEN: Separated

SHORT: Common. (The connector “DGND” can be open.) <Default>

[JP5] (VD1): Regulator (+3.3V) or VD1 connector

OPEN: VD1 pin is supplied from VD1 connector.

SHORT: VD1 pin is supplied to regulator (+3.3V). (The connector “VD1” can be open.) <Default>

[JP6] (VVD): Regulator (+3.3V) or VVD connector
 OPEN: VVD and HVVD pins are supplied from VVD connector.
 SHORT: VVD and HVVD pins are supplied from regulator (+3.3V)
 (The connector "VVD" can be open.) <Default>

[JP7] (D3.3V): Regulator (+3.3V) or D3.3V connector
 OPEN: Logic voltage is supplied from D3.3V connector.
 SHORT: Logic voltage is supplied form regulator (+3.3V). (The connector "VCC" can be open.) <Default>

The regulator can be supplied 3.3V to all circuits by shorting JP5, JP6 and JP7 and supplying 12V to VP connector.

■ The function of the toggle SW

[S1] (PDN): Resets the AK4711. Keep "H" during normal operation.

■ Bord Control

The AK4711 can be controlled USB PORT of PC. Connect PORT1 with PC by USB cable packed with the AKD4711-A. The control software packed with this evaluation board

■ Analog Input/Output List

		Signal Name	Note
Audio	Input	J5(AINL+, AINL-), J13(AINR+, AINR-)	Max. 2Vrms
	Output	J4 (TVOUTL), J9 (TVOUTR), J6 (CHINOUTL), J14 (CHINOUTR)	Max. 2.2Vrms
Video	Input	J2 (ENCV), J7 (ENCY), J10 (ENCRC), J15 (ENCC), J17 (ENCG), J19(ENCB)	Max. 1.25Vpp
	Output	J3 (TVVOUT), J8 (TVRC), J11(TVG), J16(TVB), J18 (RCAVOUT), J20 (HDY), J21(HDPB), J23(HDPR)	Max. 2.5Vpp
Fast Blanking	Output	J22 (TVFB),	Max. VVD
Slowt Blanking	Output	J24 (TVSB)	Max. VP

Table 2. Analog Input/Output List

Control Soft Manual

■ Evaluation Board and Control Soft Settings

1. Set an evaluation board properly.
2. Connect Evaluation board to PC with USB cable.
 USB control is recognized as HID (Human Interface Device) on the PC.
 When it can not be recognized correctly please reconnect Evaluation board to PC with USB cable.
3. Proceed evaluation by following the process below.

[Support OS]

- Windows 2000 / XP
- 64bit OS's are not supported.
- Windows 95 / 98 / Me / NT are not supported.

■ Operation Screen

1. Start up the control program following the process above.
2. After the evaluation board's power is supplied, the AK4711 must be reset once bring S1 (AK4711-PDN) "L" to "H".
3. The operation screen is shown below

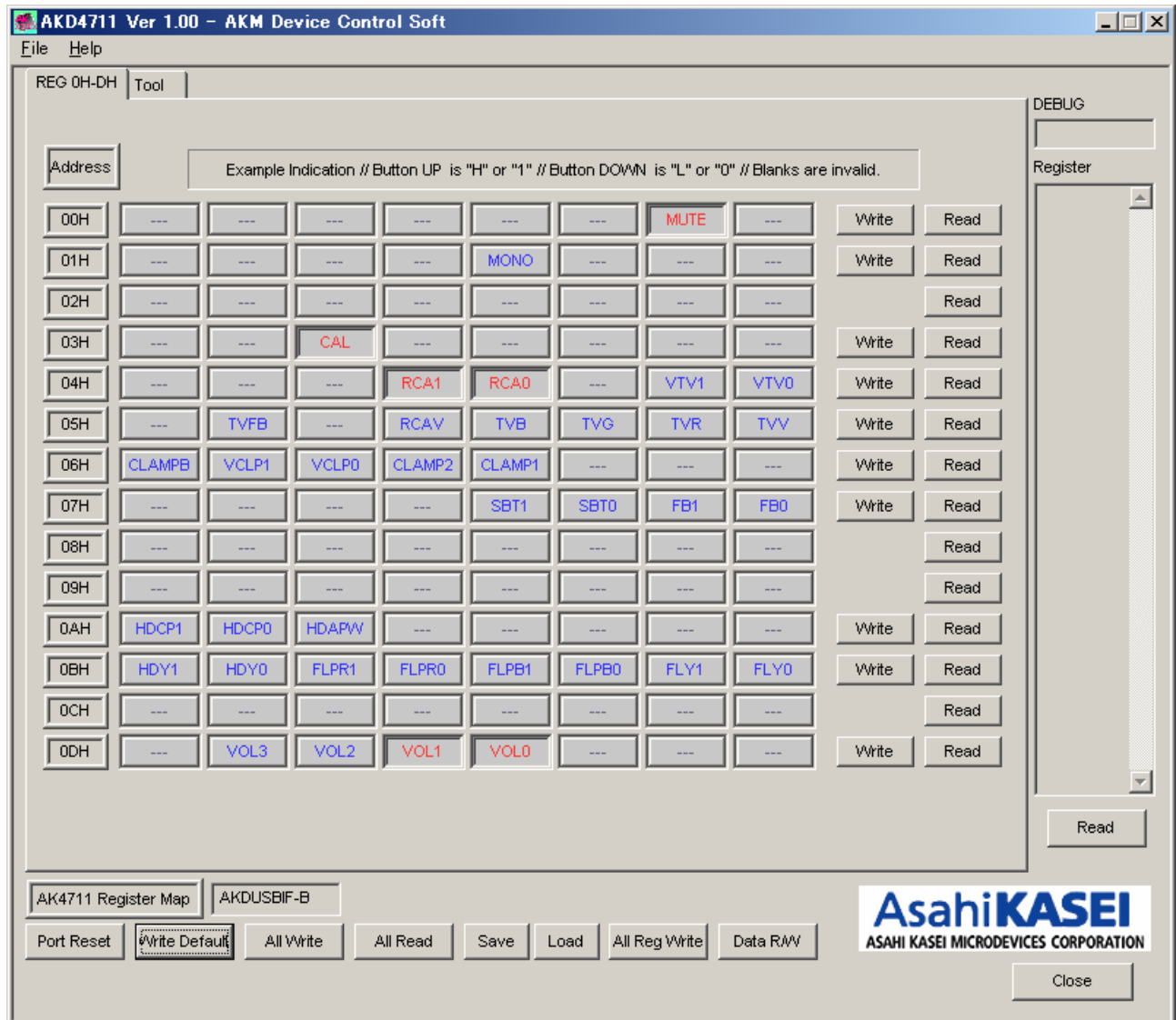

■ Operation Overview

Function, register map and testing tool can be controlled by this control soft. These controls are selected by upper tabs.

Buttons which are frequently used such as register initializing button “Write Default”, are located outside of the switching tab window. Refer to the “■ Dialog Boxes” for details of each dialog box setting.

1. [Port Reset]: For when connecting to PC with USB cable
Click this button after the control soft starts up when connecting to PC with USB cable.
2. [Write Default]: Register Initializing
When the device is reset by a hardware reset, use this button to initialize the registers.
3. [All Write]: Executing write commands for all registers displayed.
4. [All Read]: Executing read commands for all registers displayed.
5. [Save]: Saving current register settings to a file.
6. [Load]: Executing data write from a saved file.
7. [All Reg Write]: [All Reg Write] dialog box is popped up.
8. [Data R/W]: [Data R/W] dialog box is popped up.
9. [Read]: Reading current register settings and display on to the Register area (on the right of the main window).
This is different from [All Read] button, it does not reflect to a register map, only displaying hexadecimal.

■ Tab Functions

1. [REG]: Register Map

This tab is for a register writing and reading.

Each bit on the register map is a push-button switch.

Button Down indicates “H” or “1” and the bit name is in red (when read only it is in deep red).

Button Up indicates “L” or “0” and the bit name is in blue (when read only it is in gray)

Grayout registers are Read Only registers. They can not be controlled.

The registers which is not defined in the datasheet are indicated as “---”.

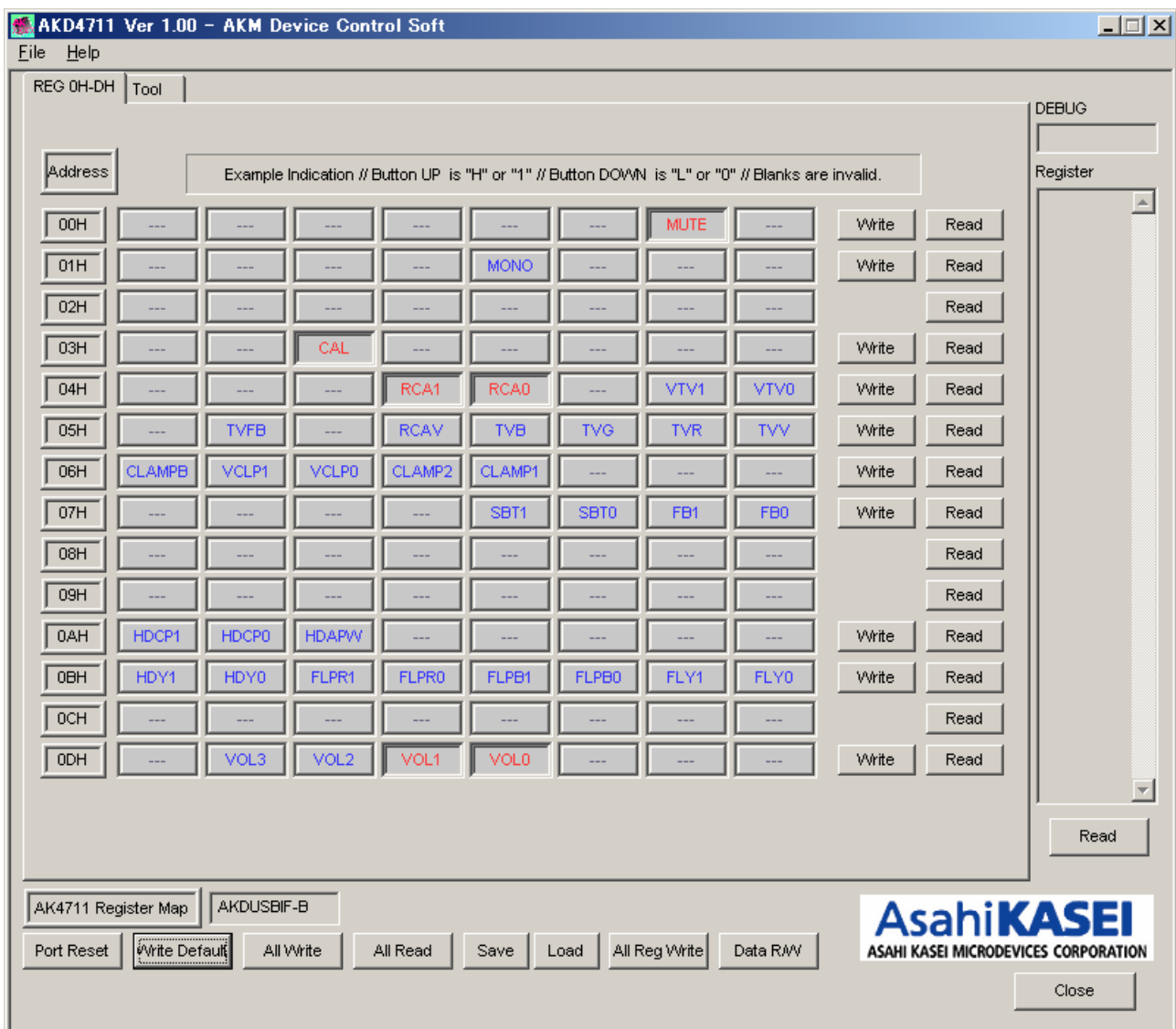

Figure 2. Window of [REG]

1-1. [Write]: Data Writing Dialog

It is for when changing two or more bits on the same address at the same time.

Click [Write] button located on the right of the each corresponded address for a pop-up dialog box.

When the checkbox is checked, the data will be “H” or “1”. When the checkbox is not checked, the data will be “L” or “0”. Click [OK] to write setting values to the registers, or click [Cancel] to cancel this setting.

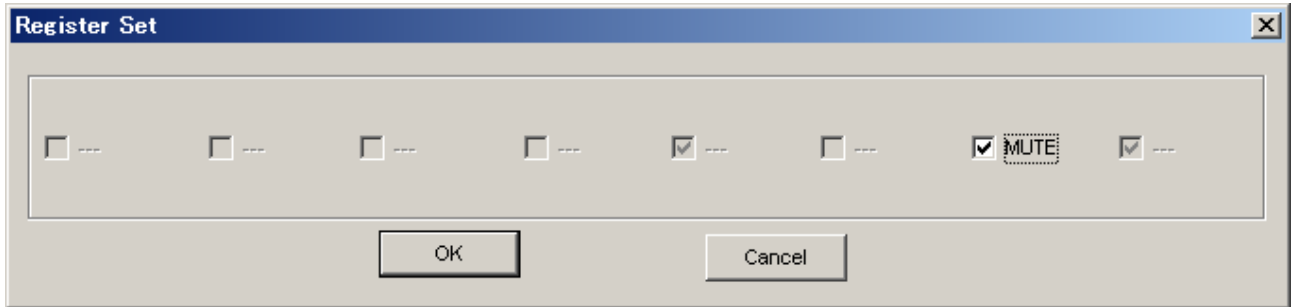

figure 3. Window of [Register Set]

1-2. [Read]: Data Read

Click [Read] button located on the right of the each corresponded address to execute a register read.

After register reading, the display will be updated regarding to the register status.

Button Down indicates “H” or “1” and the bit name is in red (when read only it is in deep red).

Button Up indicates “L” or “0” and the bit name is in blue (when read only it is in gray)

Please be aware that button statuses will be changed by a Read command.

2. [Tool]: Testing Tools

Evaluation testing tools are available in this tab.
Click buttons for each testing tool.

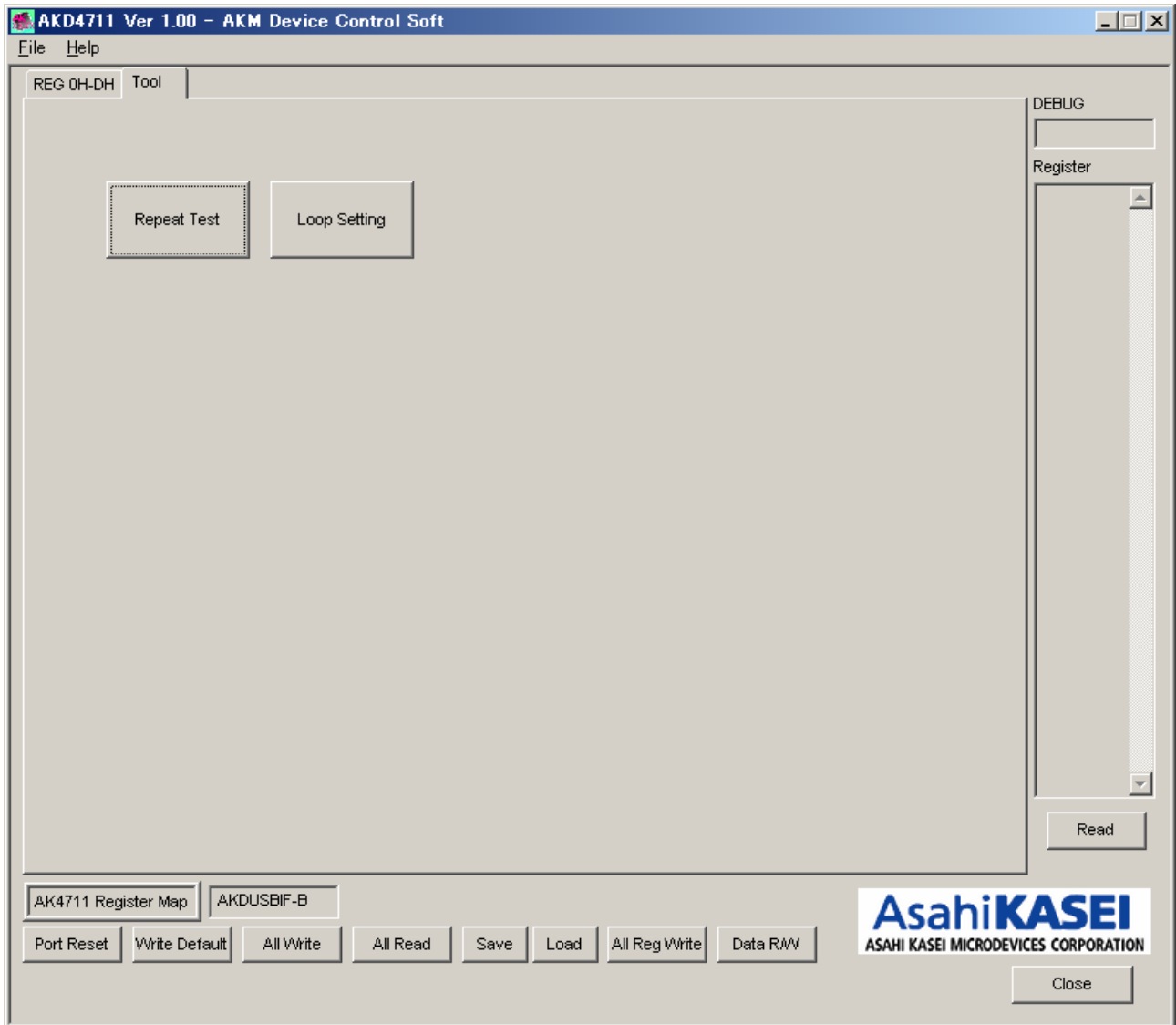

Figure 4. Window of [Tool]

2-1. [Repeat Test]: Repeat Test Dialog

Click [Repeat Test] button in the Test tab to open a repeat test dialog shown below. Repeat writing test can be executed by this dialog.

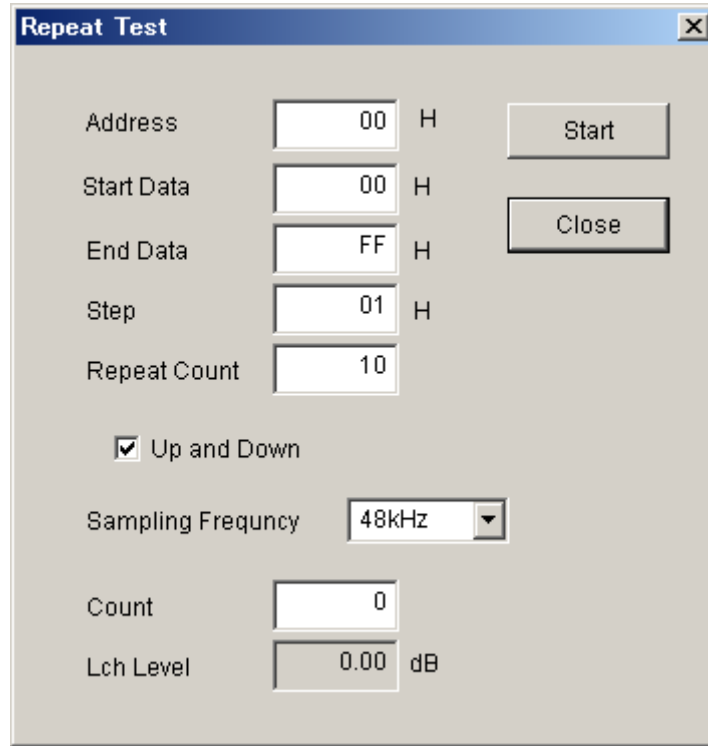

Figure 5. Window of [Repeat Test]

- [Start] Button : Starts the repeat test.
A dialog for saving a file of the test result will open when clicking this button. Name the file.
Test will start after specifying a saving file.
- [Close] Button : Closes this dialog and finishes the process.
- [Address] Box : Data writing address in hexadecimal numbers.
- [Start Data] Box : Start data in hexadecimal numbers.
- [End Data] Box : End data in hexadecimal numbers.
- [Step] Box : Data write step interval.
- [Repeat Count] Box : Repeat count of the test writing.
- [Up and Down] Box : Data write flow is changed as below.
 - Checked: Writes in step interval from the start data to the end data and turn back from the end data to the start data.
[Example] Start Data = 00, End Data = 05, Step = 1, []...for 1 count.
Data flow: [00→01→02→03→04→05→05→04→03→02→01→00] x Repeat Count Number
 - Not checked: Writes in step interval from the start data to the end data and finishes writing.
[Example] Start Data = 00, End Data = 05, Step = 1, []...for 1 count.
Data flow: [00→01→02→03→04→05] x Repeat Count Number
- [Sampling Frequency] Box: Selects sampling frequency 44.1kHz/48kHz
- [Count] Box : Indicates the count number during a repeat test.
- [Lch Level] Box : Indicates the Lch Level during a repeat test.

2-2. [Loop Setting]: Loop Dialog

Click [Loop Setting] button in the Tool tab to open loop setting dialog as shown below.
Writing test can be executed.

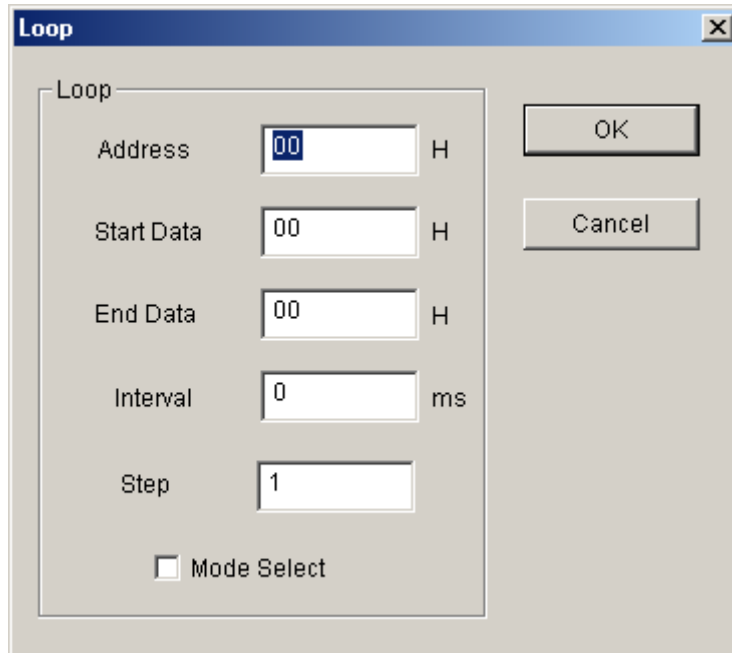

Figure 6. Window of [Loop]

- [OK] Button : Starts the test.
- [Cancel] Button : Closes the dialog and finishes the process.
- [Address] Box : Data writing address in hexadecimal numbers.
- [Start Data] Box : Start data in hexadecimal numbers.
- [End Data] Box : End data in hexadecimal numbers.
- [Interval] Box : Data write interval time.
- [Step] Box : Data write step interval.
- [Mode Select] Box : Mode select check box.

- Checked: Writes in step interval from the start data to the end data and turn back from the end data to the start data.

[Example] Start Data = 00, End Data = 05, Step = 1
Data flow: 00→01→02→03→04→05→05→04→03→02→01→00

- Not Checked: Writes in step interval from the start data to the end data and finishes writing.

[Example] Start Data = 00, End Data = 05, Step = 1
Data flow: 00→01→02→03→04→05

■ Dialog Boxes

1. [All Reg Write]: All Reg Write dialog box

Click [All Reg Write] button in the main window to open register setting files.
 Register setting files saved by [SAVE] button can be applied.

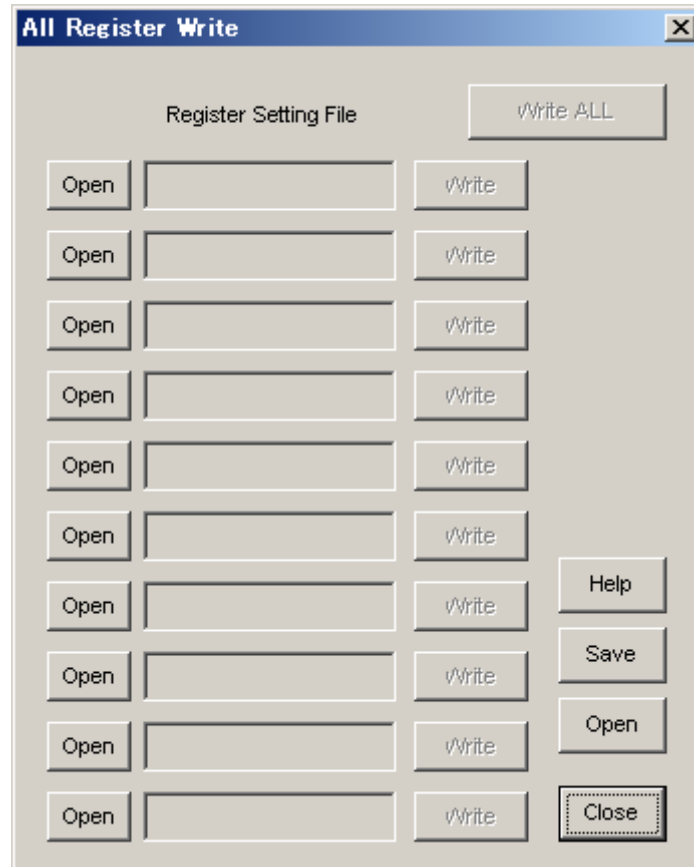

Figure 7. Window of [All Reg Write]

- [Open (left)]: Selects a register setting file (*.akr).
- [Write]: Executes register writing by the setting of selected file.
- [Write All]: Executes all register writings.
 Selected files are executed in descending order.

- [Help]: Opens a help window.
- [Save]: Saves a register setting file assignment. The file name is “*.mar”.
- [Open (right)]: Opens a saved register setting file assignment “*.mar”.
- [Close]: Closes the dialog box and finish the process.

~ Operating Suggestions ~

1. Those files saved by [Save] button and opened by [Open] button on the right of the dialog “*.mar” should be stored in the same folder.
2. When register settings are changed by [Save] button in the main window, re-read the file to reflect new register settings.

2. [Data R/W]: Data R/W Dialog Box

Click the [Data R/W] button in the main window for data read/write dialog box.
Data write is available to specified address.

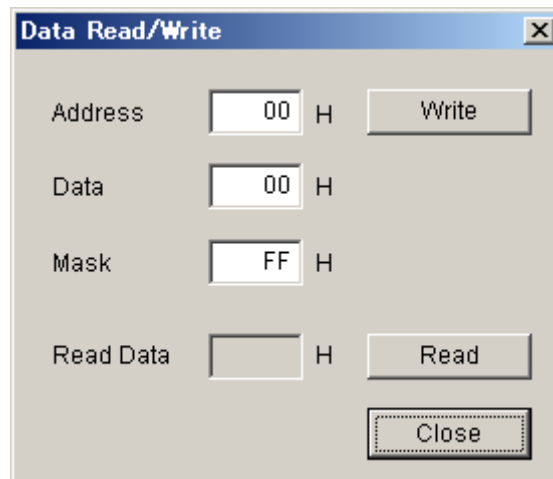

Figure 8. Window of [Data R/W]

[Address] Box: Input data address in hexadecimal numbers for data writing.

[Data] Box : Input data in hexadecimal numbers.

[Mask] Box : Input mask data in hexadecimal numbers.
This is “AND” processed input data.

[Write]: Writes the data generated from Data and Mask values to the address specified by “Address” box.

[Read]: Reads data from the address specified by “Address” box.
The result will be shown in the Read Data Box in hexadecimal numbers.

[Close]: Closes the dialog box and finishes the process.
Data writing can be cancelled by this button instead of executing a write command.

*The register map will be updated after executing [Write] or [Read] commands.

MEASUREMENT RESULTS

■ Audio

[Measurement condition]

- Measurement unit : Audio Precision SYS-2722
- BW : 20Hz~20kHz
- Power Supply : VP=12V, VD1=3.3V, VD2=3.3V, VDD1=3.3V, VDD2=3.3V
- Interface : Input: Cannon, Output: BNC
- Temperature : Room
- Volume Gain : 0dB
- Measurement signal line path: AINL/AINR → Volume → TVOUTL/TVOUTR

Parameter	Input signal	Measurement filter	Results Lch [dB]	Results Rch [dB]
S/(N+D) (At 2Vrms Output)	1kHz, 0dBFS	20kLPF	96.3	96.2
DR	1kHz, -60dBFS	22kLPF, A-weighted	100.8	100.8
S/N	“no-input	22kLPF, A-weighted	100.8	100.8

Plots

Figure 1-1. FFT (1kHz, 0dBFS input) at 2Vrms output

Figure 1-2. FFT (1kHz, -60dBFS input)

Figure 1-3. FFT (Noise floor)

Figure 1-4. THD+N vs. Input Level (fin=1kHz)

Figure 1-5. THD+N vs. fin (Input Level=0dBFS)

Figure 1-6. Linearity (fin=1kHz)

Figure 1-7. Frequency Response (Input Level=0dBFS)

Figure 1-8. Crosstalk (Input Level=0dBFS)

■ Video

[Measurement condition]

- Signal Generator : Sony Tectronix TG2000
- Measurement unit : Sony Tectronix VM700T
- Power Supply : VP=12V, VD1=3.3V, VD2=3.3V, VDD1=3.3V, VDD2=3.3V
- Interface : Input: BNC, Output: BNC
- Temperature : Room
- Measurement signal line path: S/N: ENCV → TVVOUT
 Y/C Crosstalk: ENCV → TVVOUT, ENCR C → TVRC
 DG, DP: ENCV → TVVOUT

Parameter	Input Signal	Measurement Filter	Results	Unit
S/N	0% Flat Field	BW=15kHz to 5MHz Filter=Uni-Weighted	76.2	dB
Y/C Crosstalk (Measured at TVVOUT)	100% Red Field (Y→ENC V, C→ENCR C)	BW=15kHz to Full	-58.0 (Note1)	dB
DG	Modulated 5 step		Min: -0.13 Max: 0.06	%
DP	Modulated 5 step		Min: -0.85 Max: 0.04	deg.

Plots

Figure 2-1. Noise spectrum (Input=0% Flat Field, BW=15kHz to 5MHz, Filter=Uni-Weighted)

Figure 2-2. Y/C Crosstalk (Measured at TVVOUT, Input= 100% Red, ENCV=Y, ENCR C=C), BW=15kHz to Full)

Figure 2-3. DG, DP (Input= Modulated 5 step)

(Note1) Y/C Crosstalk: Reference Measurement: Results: 1.7dB (p-p)

Composite signal→ENC V, no input→ENCR C, TVRC is terminated by 75Ohm.

Y/C Crosstalk: Measurement: Results: -57.2dB (p-p)

Y→ENC V, C→ENCR C, TVRC is terminated by 75Ohm.

Y/C Crosstalk calculation: -57.2dB (p-p) - 1.7dB (p-p) = -58.9dB (p-p)

Plots (Audio)

AK4711 AINL/AINR → TVOUTL/TVOUTR: FFT: fin=1KHz, Input Level=0dB

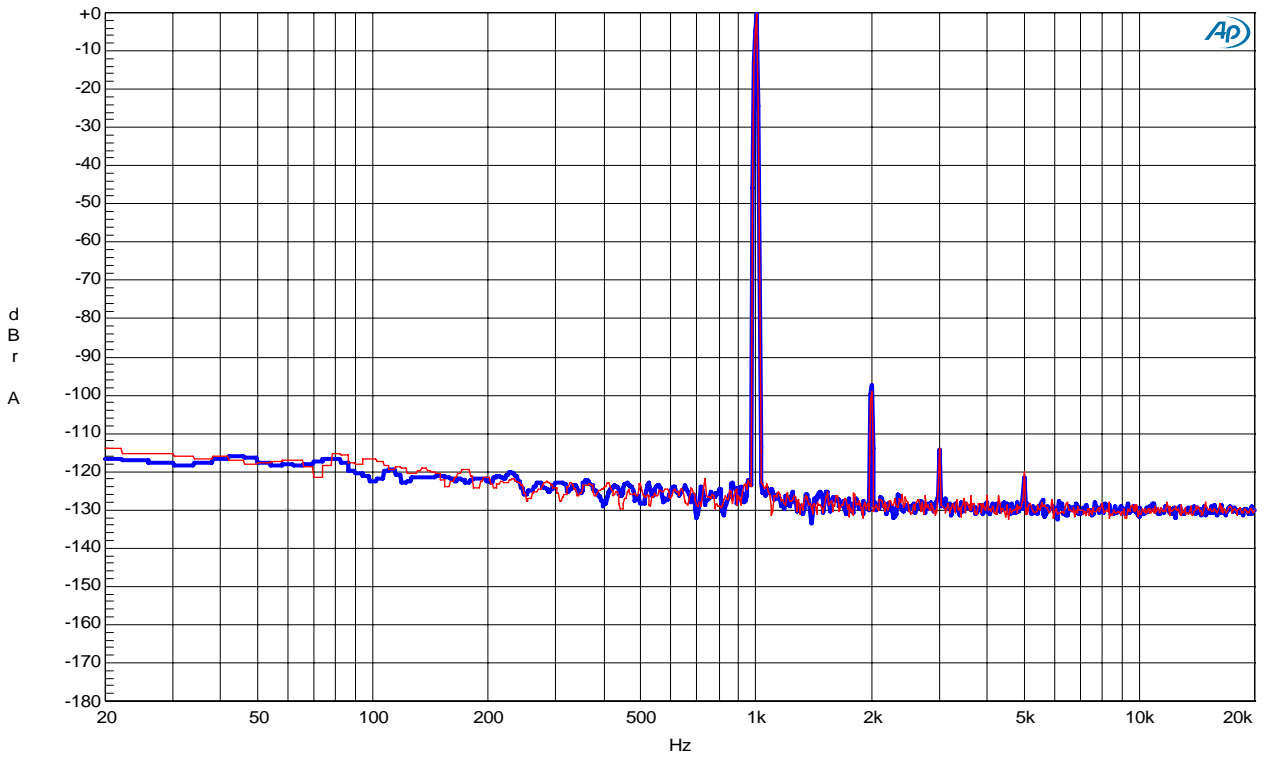

Figure1-1. FFT (fin=1kHz, Input Level=0dB)

AK4711 AINL/AINR → TVOUTL/TVOUTR: FFT: fin=1KHz, Input Level=-60dB

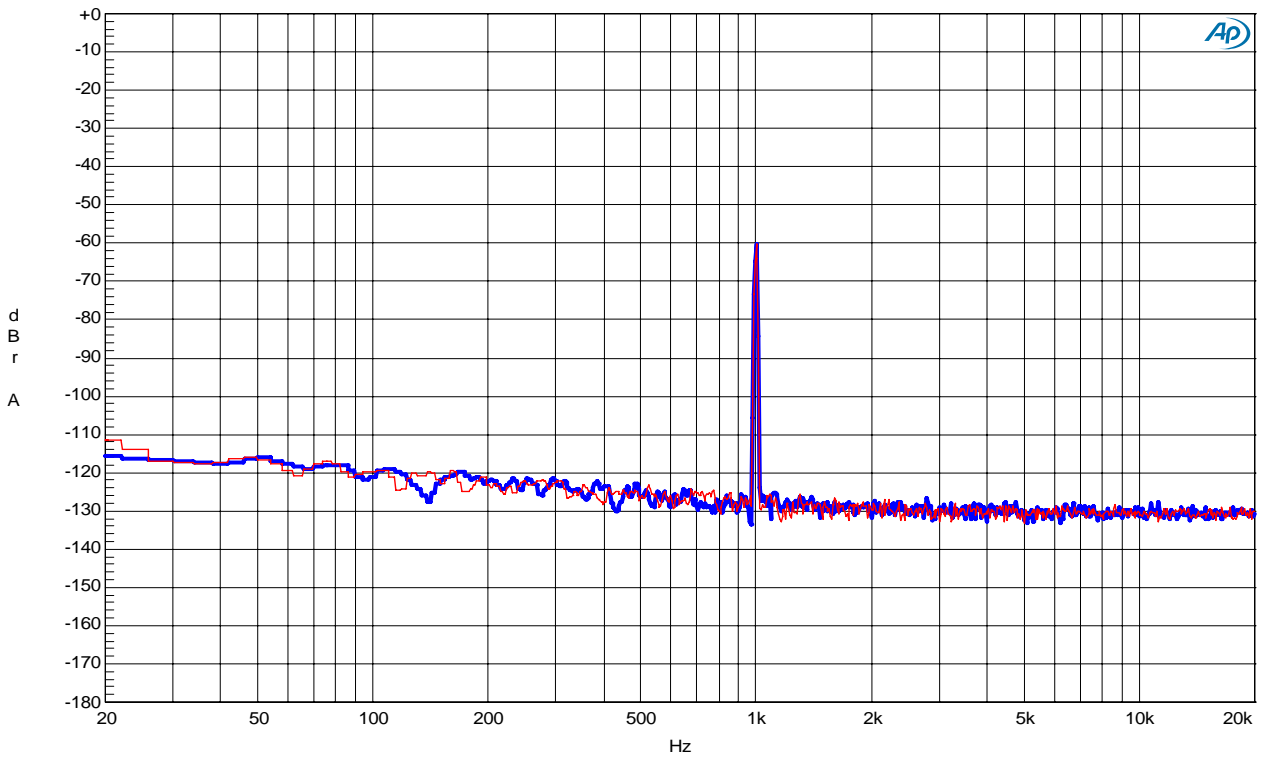

Figure-1-2. FFT (fin=1kHz Input Level=-60dB)

AK4711 AINL/AINR → TVOUTL/TVOUTR: FFT: No-input

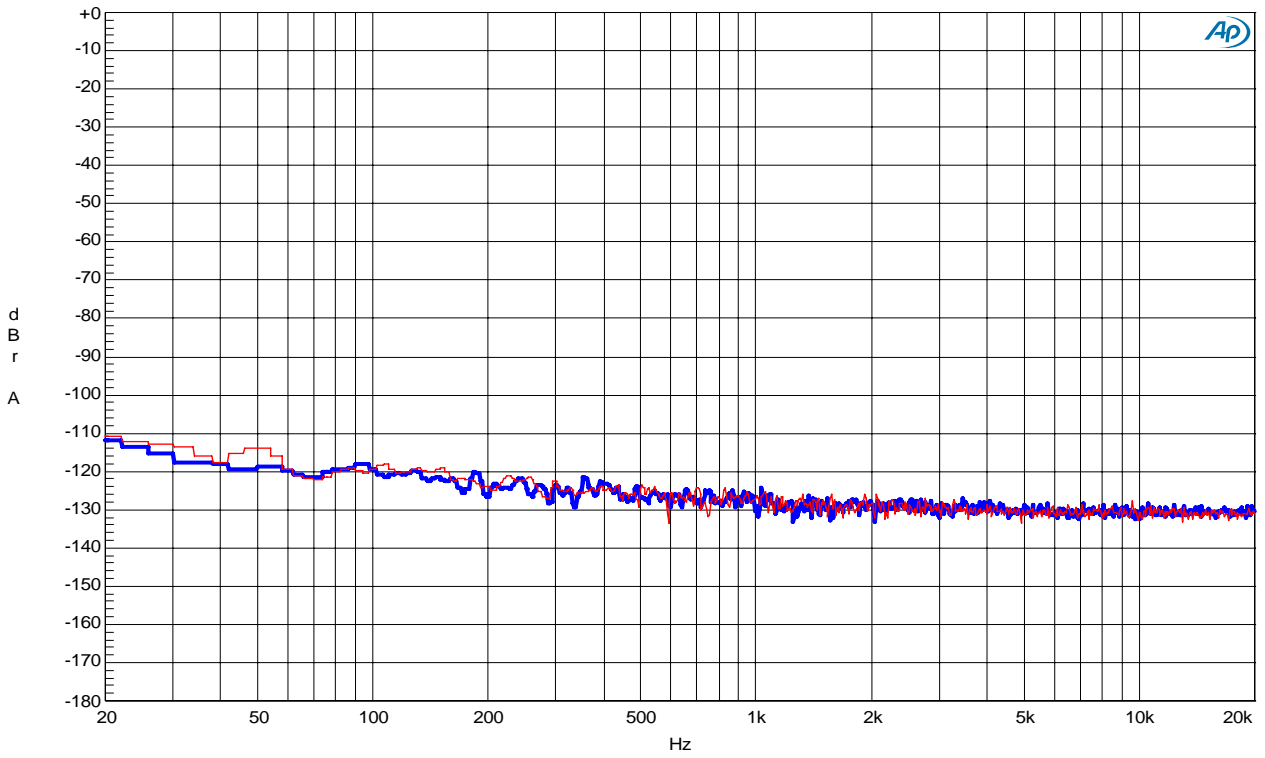

Figure1-3. FFT (Noise Floor)

AK4711 AINL/AINR → TVOUTL/TVOUTR: THD+N Amplitude vs Input Amplitude: fin=1KHz

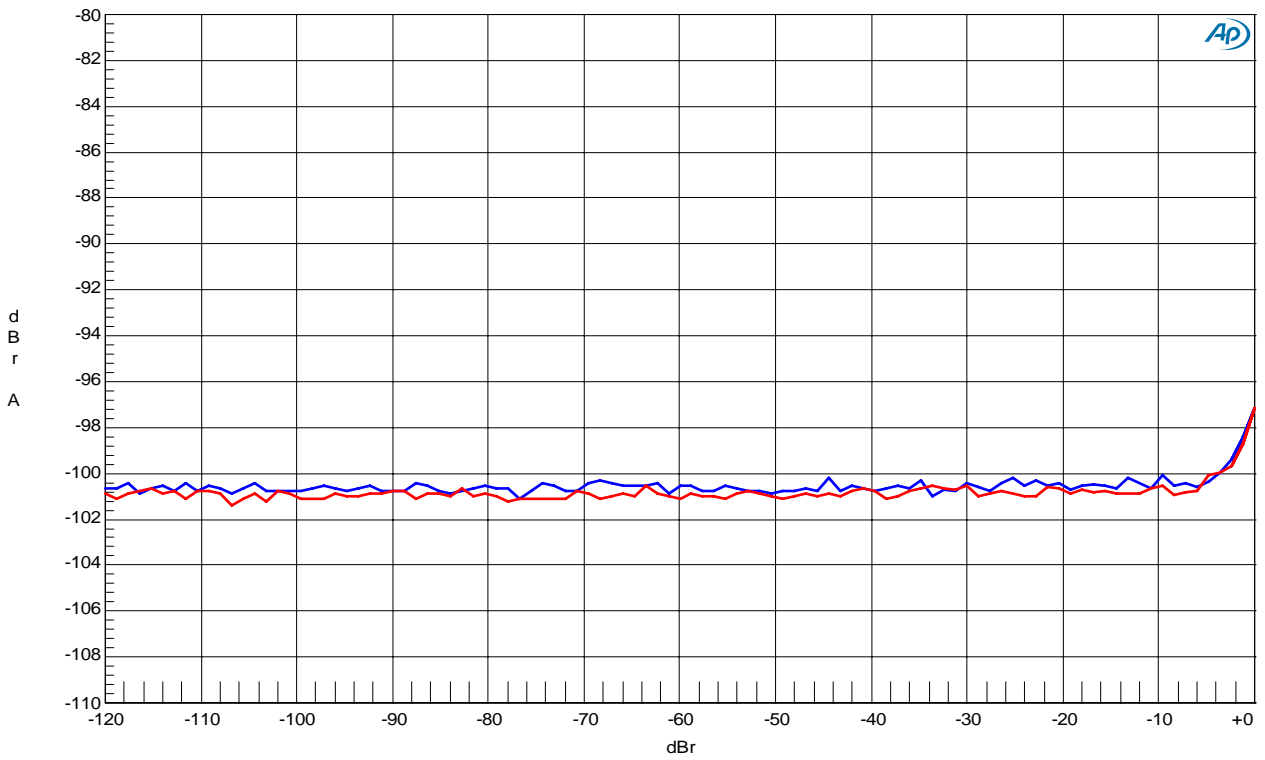

Figure1-4. THD+N vs. Input level (fin=1kHz)

AK4711 AINL/AINR → TVOUTL/TVOUTR: THD+N Amplitude vs Input Frequency: Input Level=0dB

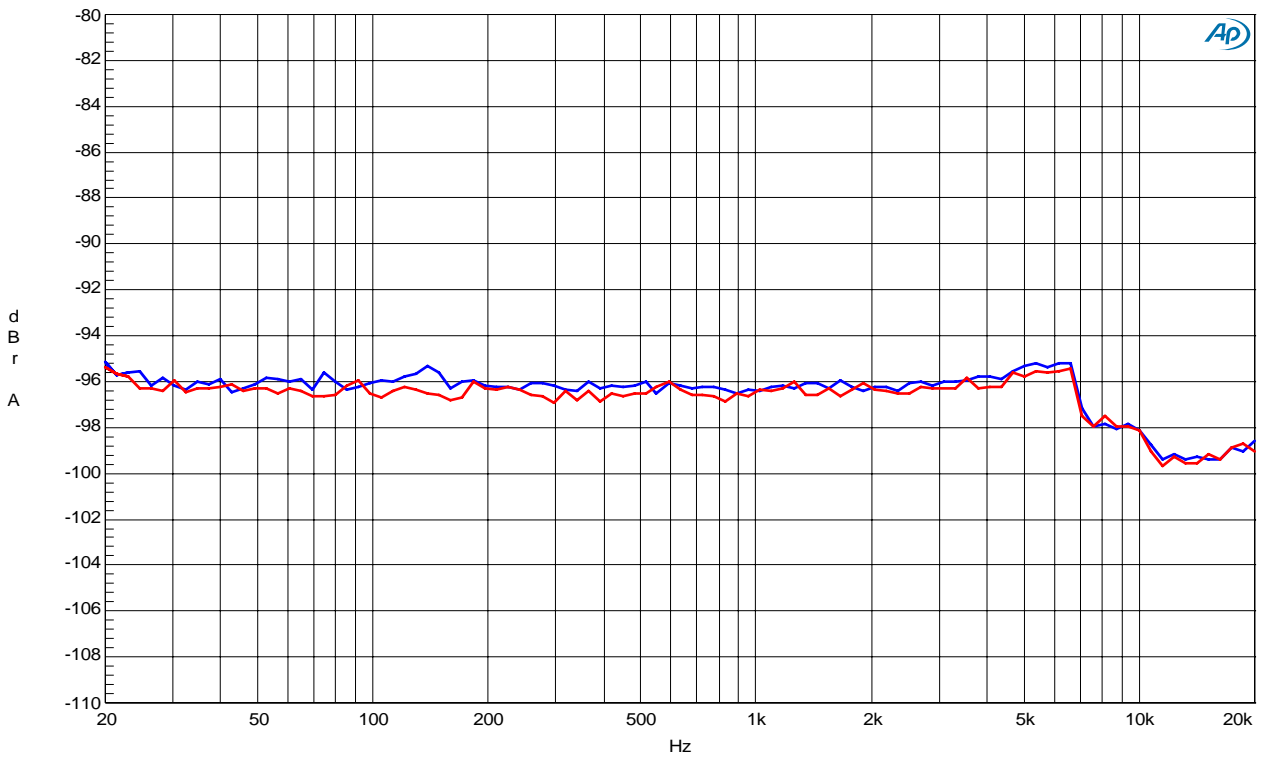

Figure1-5. THD+N vs. Input Frequency (Input level=0dB)

AK4711 AINL/AINR → TVOUTL/TVOUTR: Linearity: fin=1KHz

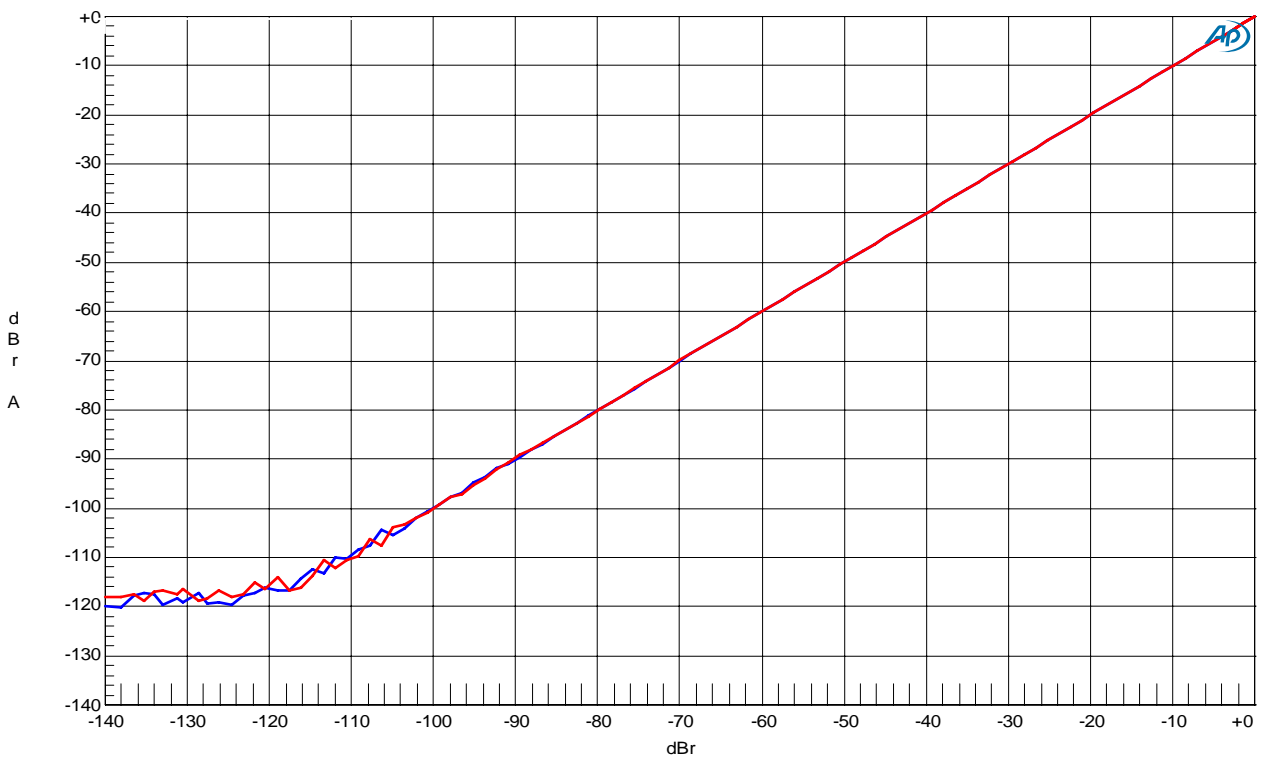

Figure1-6.Linearity (fin=1kHz)

AK4711 AINL/AINR → TVOUTL/TVOUTR: Frequency Response: Input Level=0dBr

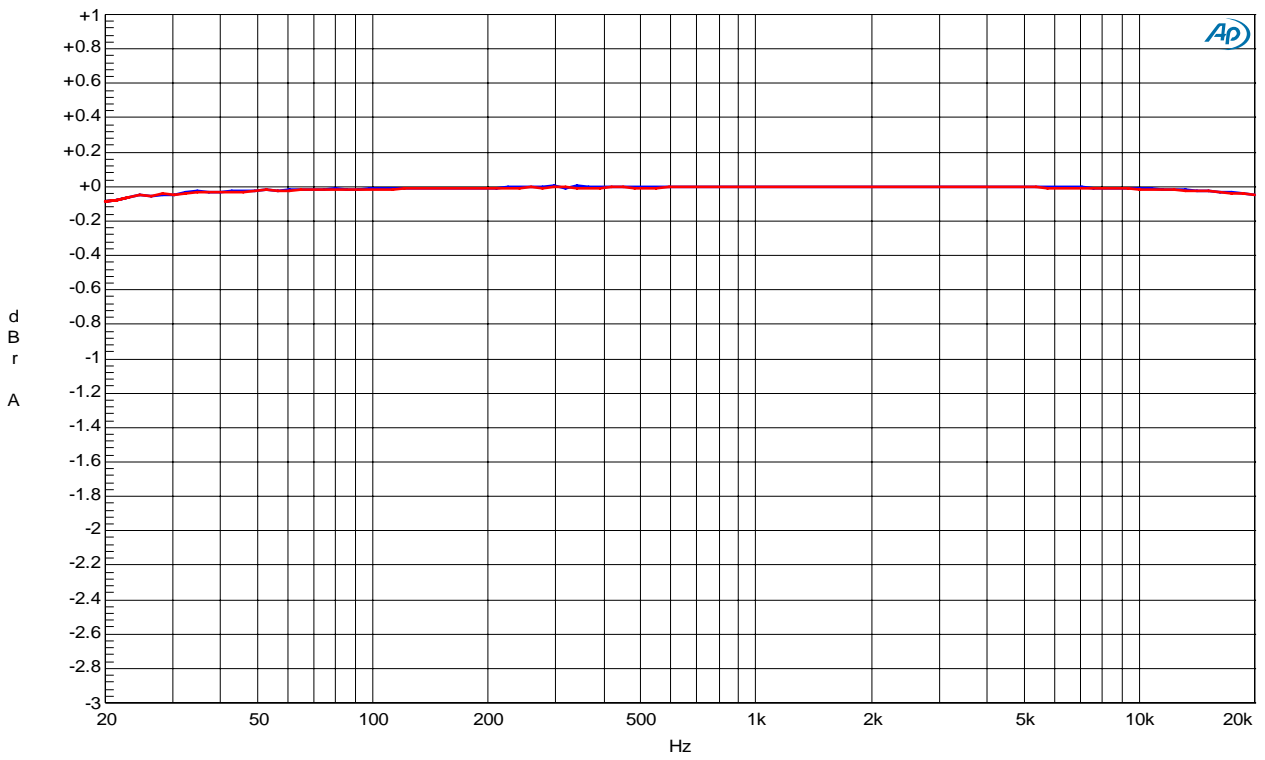

Figure1-7. Frequency Response (Input level=0dB)

AK4711 AINL/AINR → TVOUTL/TVOUTR: Crosstalk: fin=1KHz, Input Level=0dBr / No-input

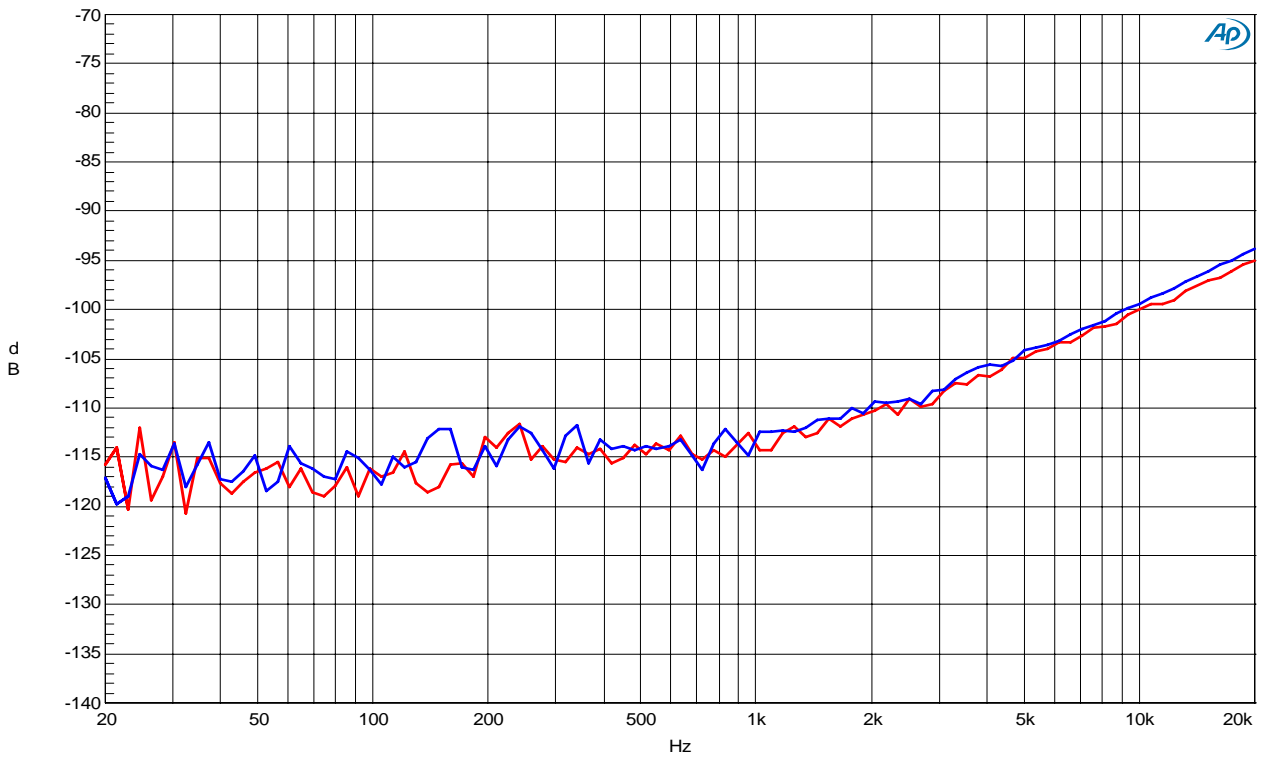

Figure1-8. Crosstalk (Input level=0dB)

Plots(Video)

AK4711 ENCVIDEO → TVVOUT: S/N: Input Signal=0% Flat Field, BW=15kHz to 5MHz, Filter=Uni-Weighted

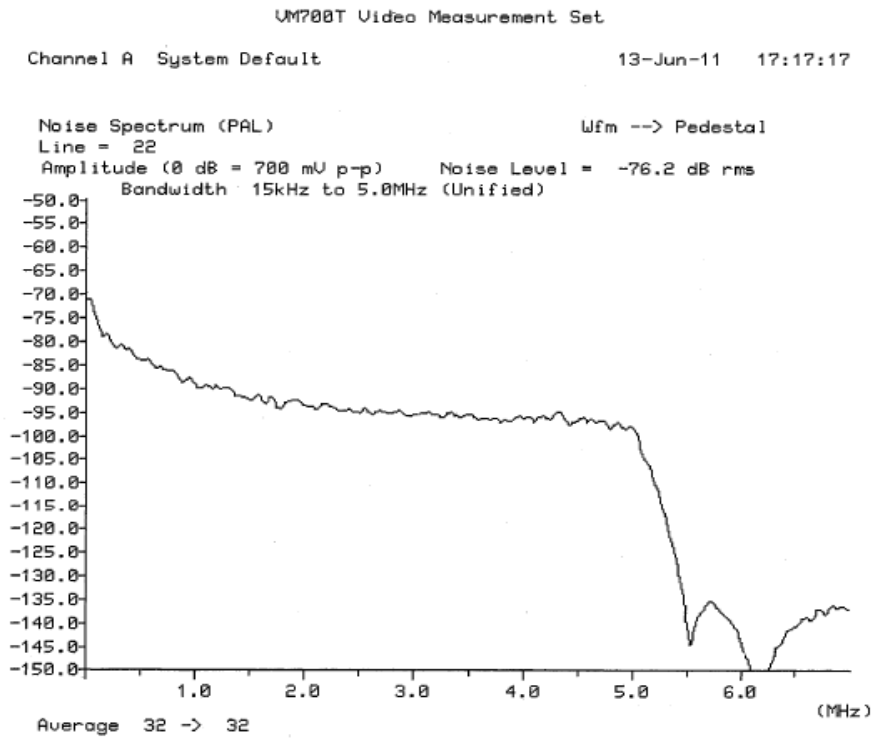

Figure 2-1. Noise spectrum (Input=0% Flat Field, BW=15kHz to 5MHz, Filter=Uni-Weighted)

AK4711 ENCV → TVVOUT / ENCRC→TVRC: Y/C Crosstalk: Input Signal=100% Red Field,
Y→ENCV, C→ENCRC, BW=15kHz to Full

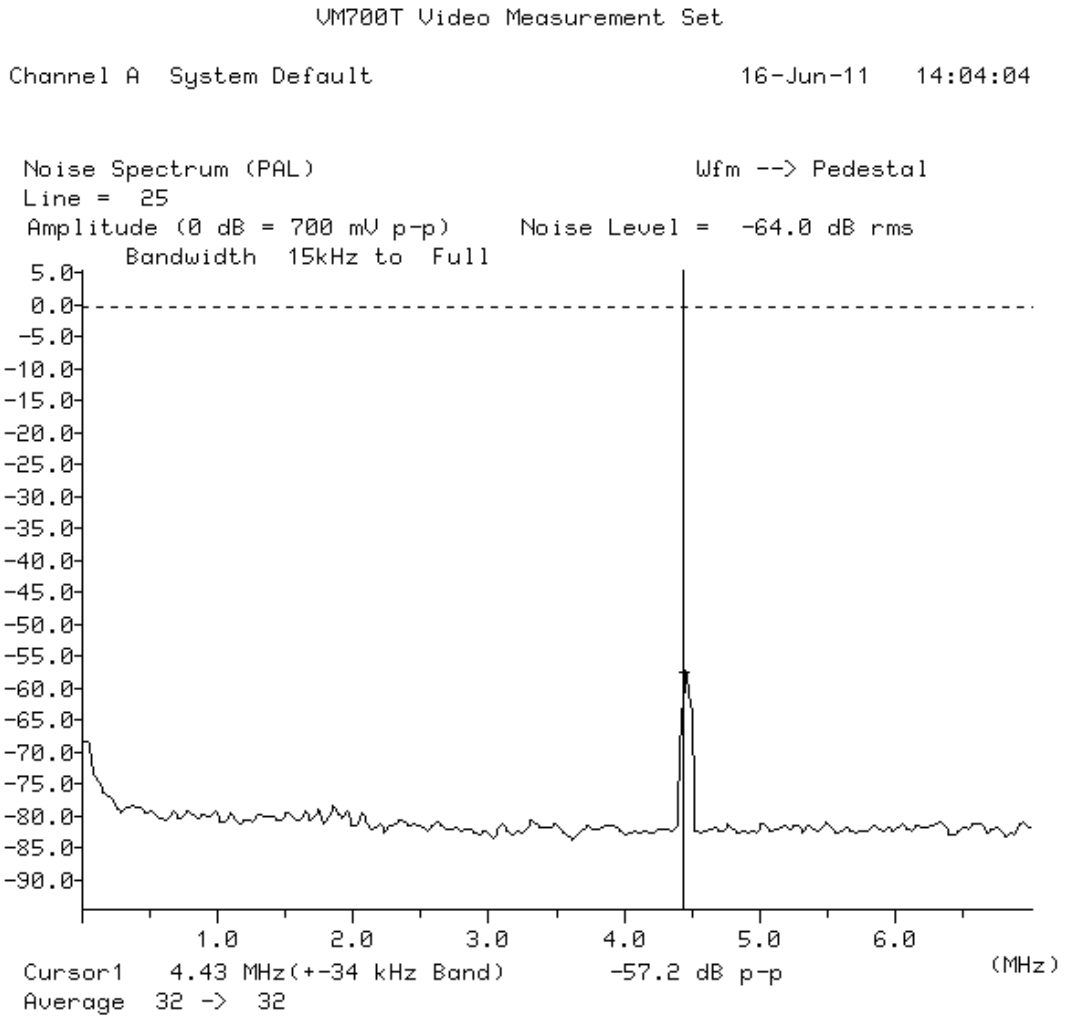

Figure 2-2 Crosstalk (Measured at TVVOUT, Input= 100% Red Field, Y→ENCV, C→ENCRC, BW=15kHz to Full)

AK4711 ENCV → TVVOUT: DG, DP: Input Signal=Modulated 5 step

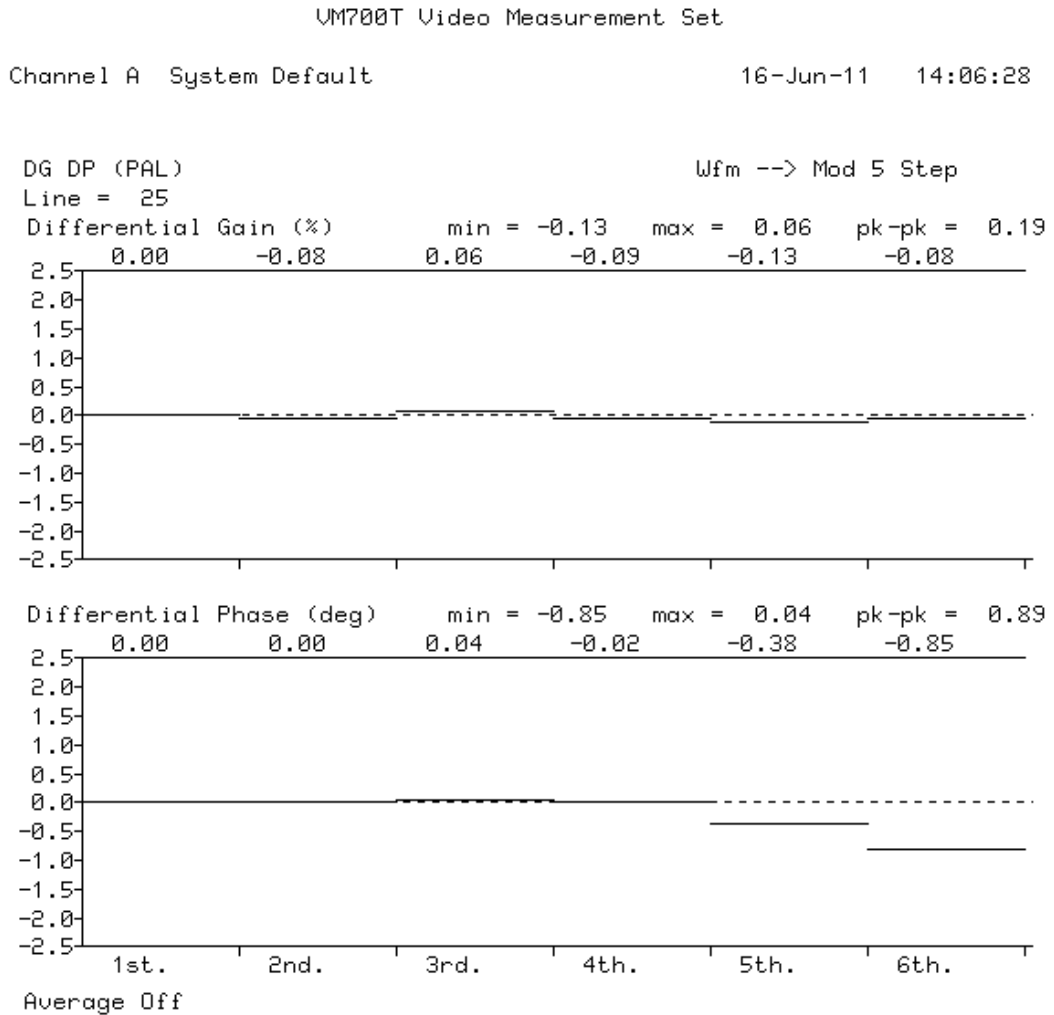

Figure 2-3 DG, DP (Input Signal= Modulated 5 step)

Revision History

Date (YY/MM/DD)	Manual Revision	Board Revision	Reason	Contents
11/02/01	KM105800	0	First Edition	
11/06/16	KM105801	1	Modification	Update of measurement results and Plots

IMPORTANT NOTICE

- These products and their specifications are subject to change without notice.
When you consider any use or application of these products, please make inquiries the sales office of Asahi Kasei Microdevices Corporation (AKM) or authorized distributors as to current status of the products.
- Descriptions of external circuits, application circuits, software and other related information contained in this document are provided only to illustrate the operation and application examples of the semiconductor products. You are fully responsible for the incorporation of these external circuits, application circuits, software and other related information in the design of your equipments. AKM assumes no responsibility for any losses incurred by you or third parties arising from the use of these information herein. AKM assumes no liability for infringement of any patent, intellectual property, or other rights in the application or use of such information contained herein.
- Any export of these products, or devices or systems containing them, may require an export license or other official approval under the law and regulations of the country of export pertaining to customs and tariffs, currency exchange, or strategic materials.
- AKM products are neither intended nor authorized for use as critical components_{Note1}) in any safety, life support, or other hazard related device or system_{Note2}), and AKM assumes no responsibility for such use, except for the use approved with the express written consent by Representative Director of AKM. As used here:
 - Note1) A critical component is one whose failure to function or perform may reasonably be expected to result, whether directly or indirectly, in the loss of the safety or effectiveness of the device or system containing it, and which must therefore meet very high standards of performance and reliability.
 - Note2) A hazard related device or system is one designed or intended for life support or maintenance of safety or for applications in medicine, aerospace, nuclear energy, or other fields, in which its failure to function or perform may reasonably be expected to result in loss of life or in significant injury or damage to person or property.
- It is the responsibility of the buyer or distributor of AKM products, who distributes, disposes of, or otherwise places the product with a third party, to notify such third party in advance of the above content and conditions, and the buyer or distributor agrees to assume any and all responsibility and liability for and hold AKM harmless from any and all claims arising from the use of said product in the absence of such notification.
- The PCB layout diagram above is an example only. Asahi Kasei Microdevices Corporation (AKM) assumes no responsibility for any losses incurred by you or third parties arising from the use of the information herein. You are fully responsible for your PCB layout design. Please double check the mounting capability when designing PCB layout.

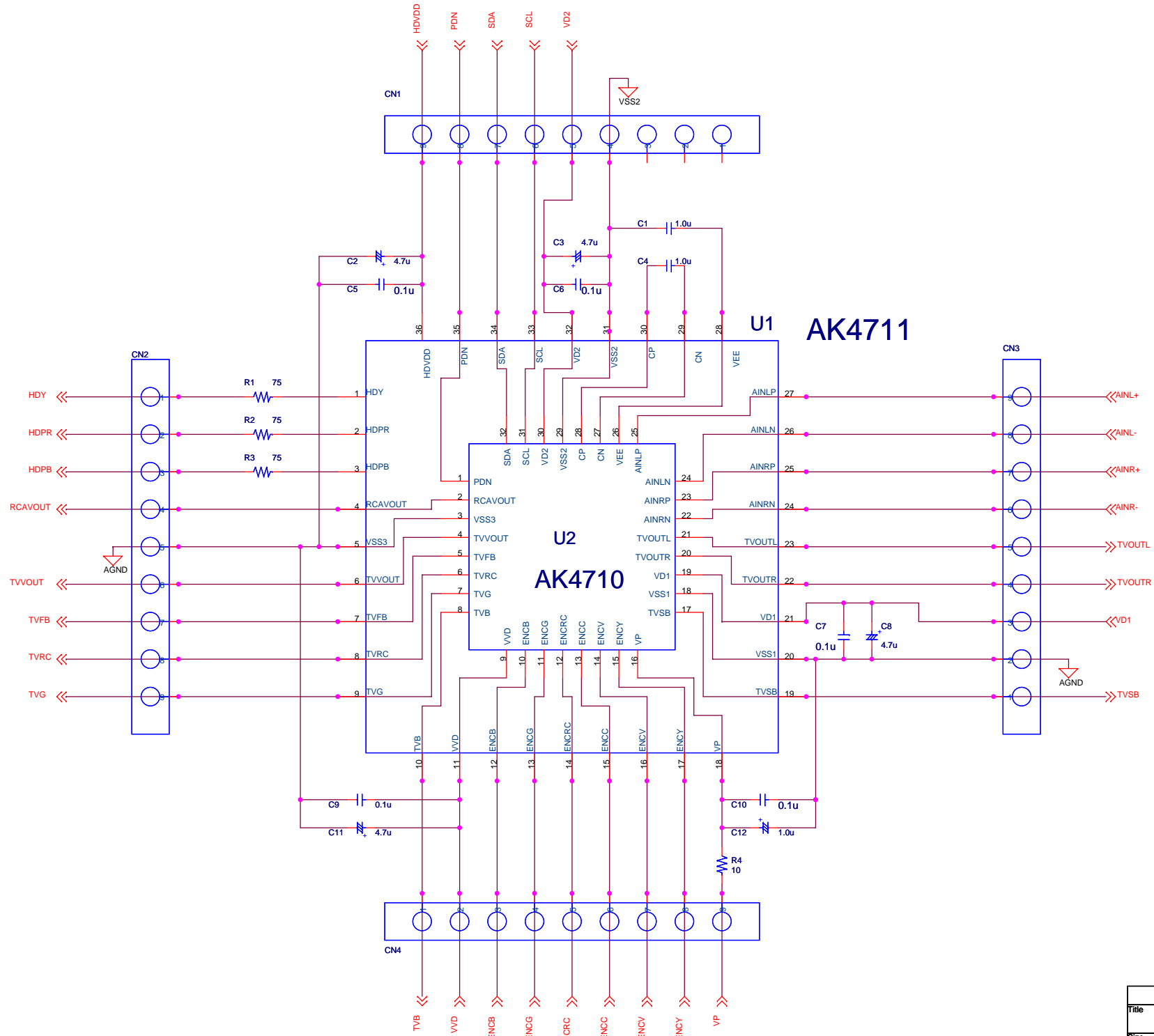

Title		
AKD4711-A_MAIN		
Size	Document Number	Rev
A3	AK4710/AK4711	0
Date:	Tuesday, December 21, 2010	Sheet 1 of 4

Video Input

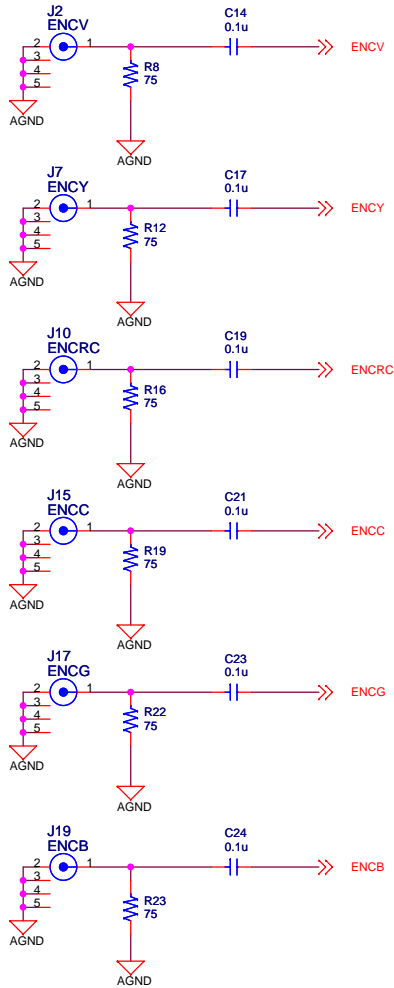

Video Output (SD)

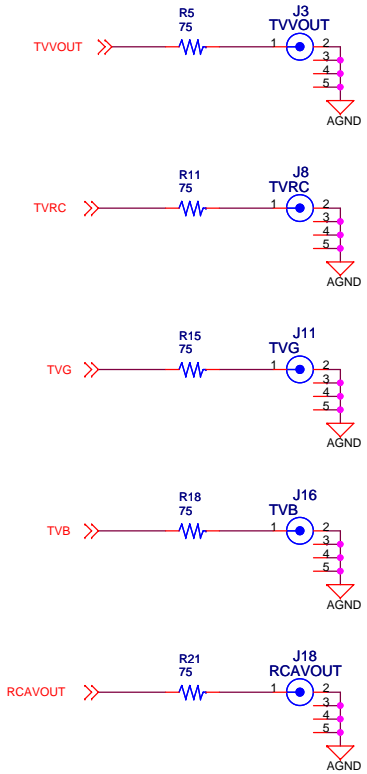

Video Output (HD)

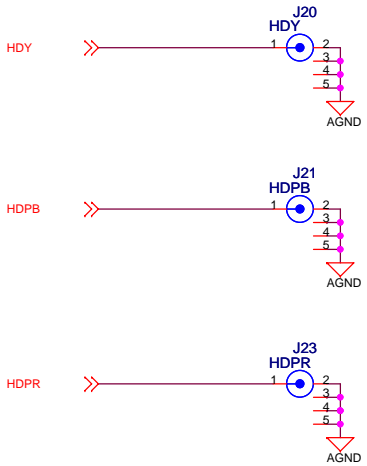

Blanking Output

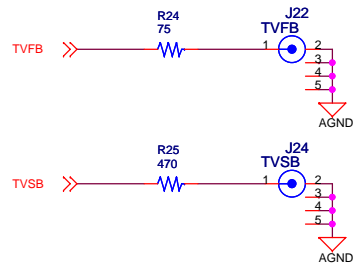

Audio Input

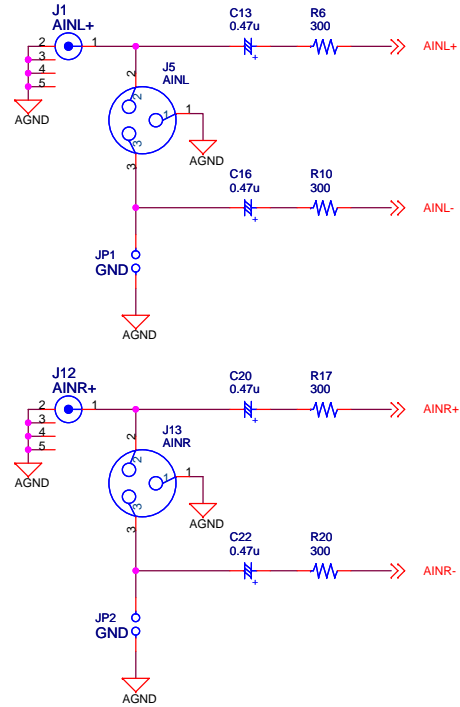

Audio Output

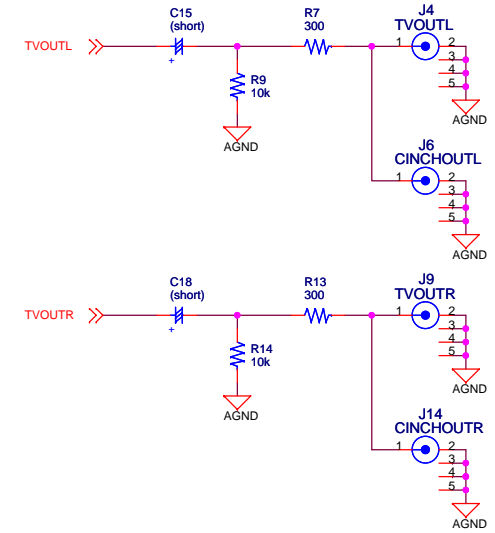

Title		
AKD4711-A-MAIN		
Size	Document Number	Rev
A3	Audio Video Input / Output	0
Date:	Monday, December 13, 2010	Sheet 2 of 4

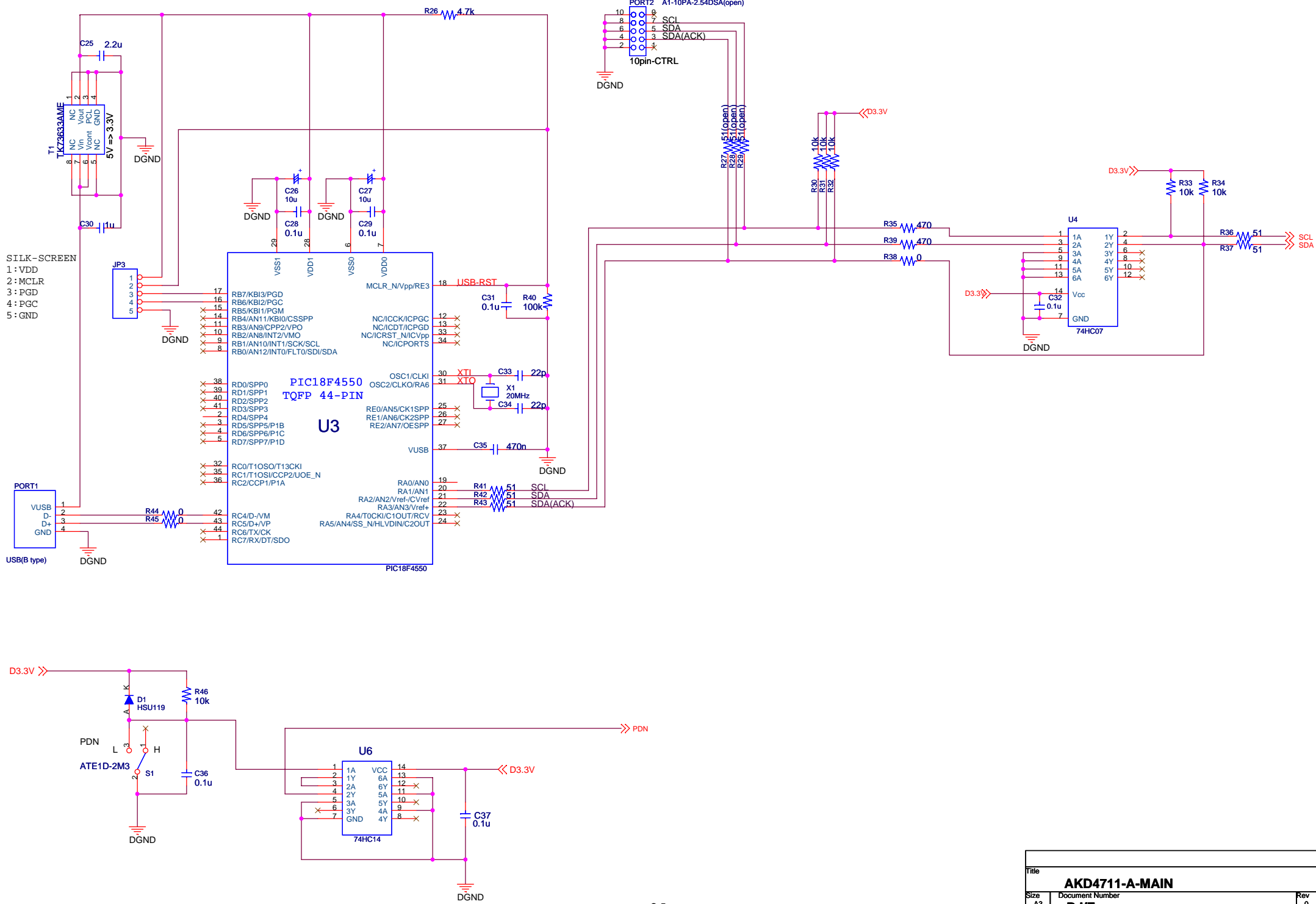

Title		
AKD4711-A-MAIN		
Size	Document Number	Rev
A3	uP-I/F	0
Date:	Friday, December 10, 2010	Sheet 3 of 4

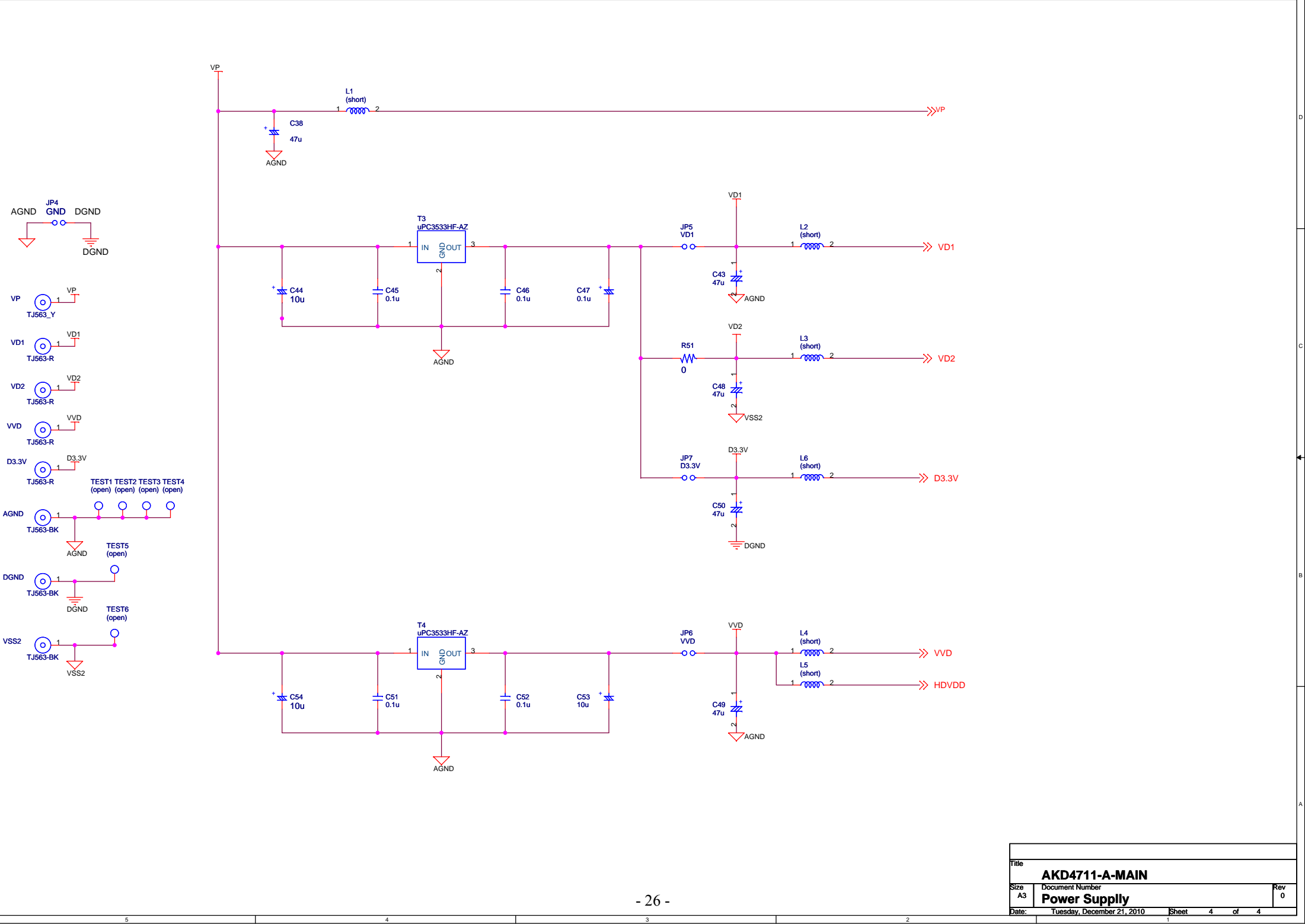

Title		
AKD4711-A-MAIN		
Size	Document Number	Rev
A3	Power Supply	0
Date:	Tuesday, December 21, 2010	Sheet 4 of 4

