

RoHS Compliant Product
A suffix of "-C" specifies halogen & lead-free

FEATURES

- High Current Capability
- Extremely Low Thermal Resistance
- For Surface Mount Application
- Higher Temp Soldering : 250°C for 10 Seconds at Terminals
- Low Reverse Current

MECHANICAL DATA

- Case: Molded Plastic
- Epoxy: UL 94V-0 Rate Flame Retardant
- Polarity: Color Band Denotes Cathode End
- Mounting Position: Any

DO-214AA (SMB)

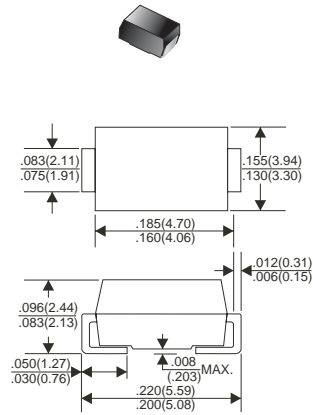

Dimensions in inches and (millimeters)

MAXIMUM RATINGS AND ELECTRICAL CHARACTERISTICS

Rating 25°C ambient temperature unless otherwise specified.
Single phase half wave, 60Hz, resistive or inductive load.
For capacitive load derate current by 20%.

TYPE NUMBER	SYMBOL	SEF112B	UNITS
Repetitive Peak reverse voltage	V_{RRM}	1200	V
RMS Voltage	V_{RMS}	850	
Average Forward Current @ $T_J=25^\circ\text{C}$	$I_{F(AV)}$	1	A
Peak Forward Current @ 8.3 ms, single half sine wave	I_{FSM}	25	A
Maximum Instantaneous Forward Voltage			
V_F @ $I_F = 1.0\text{ A}$, $T_A = 25^\circ\text{C}$	V_F	1.9 (Typ. 1.6)	V
V_F @ $I_F = 1.0\text{ A}$, $T_A = 125^\circ\text{C}$		1.6 (Typ. 1.2)	
Maximum Reverse Current			
At $V_R=1200\text{ V}$ @ $T_J = 25^\circ\text{C}$	I_R	5	μA
At $V_R=1200\text{ V}$ @ $T_J = 125^\circ\text{C}$		50	
Typical Junction Capacitance (Note 1)	C_J	4.5	pF
Typical Thermal Resistance (Note 2)	$R_{\theta JA}$	80	$^\circ\text{C}/\text{W}$
Reverse recovery time $I_F = 0.5\text{ A}$, $I_{RR} = 0.25\text{ A}$, $I_R = 1\text{ A}$	T_{RR}	75 (Typ. 60)	nS
Operating Temperature Range	T_J	-50 ~ + 175	$^\circ\text{C}$
Storage temperature	T_{STG}	-65 ~ + 175	$^\circ\text{C}$

NOTES:

1. Measured at 1MHz and applied reverse voltage of 5.0 V D.C.
2. Thermal Resistance Junction to Ambient. Printed circuit board FR4 copper pad 1x1cm, 35um thickness

RATINGS AND CHARACTERISTIC CURVES

Maximum Non- Repetitive Forward Surge Current

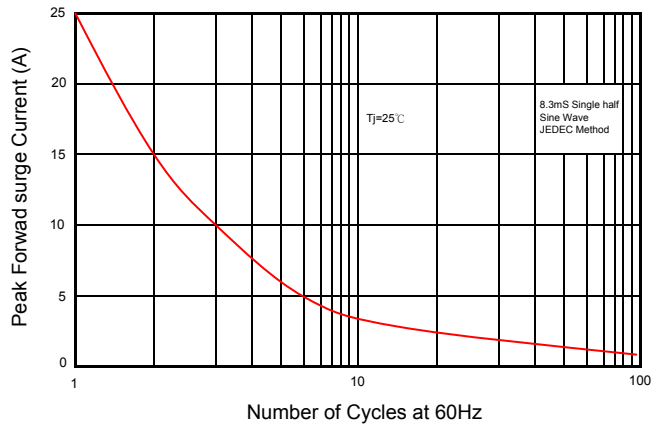

Typical Junction Capacitance

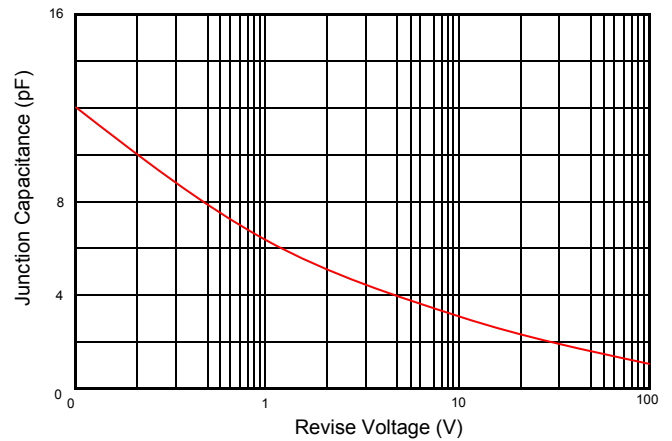

Typical Reverse Characteristic

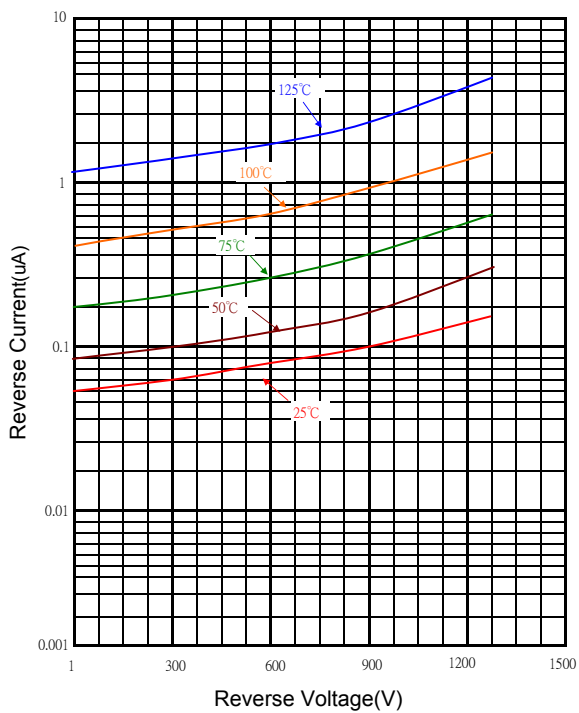

Typical Forward Characteristic

