

MARKING "F"

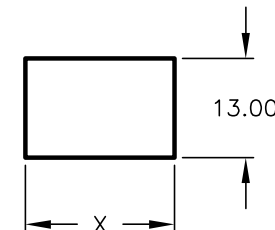
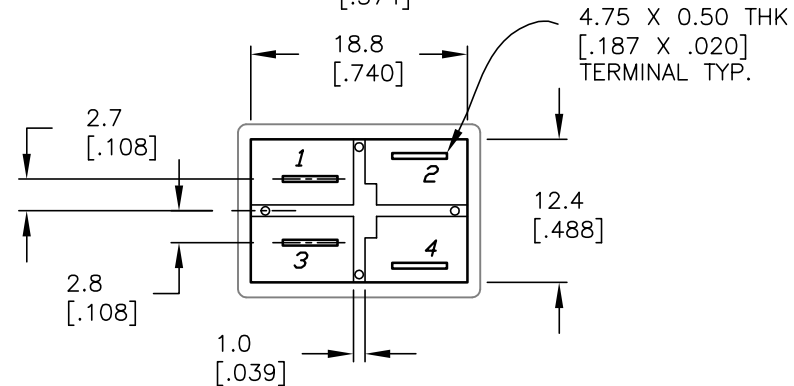
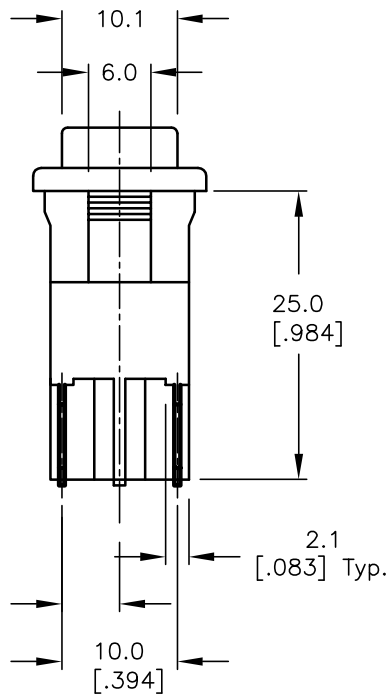
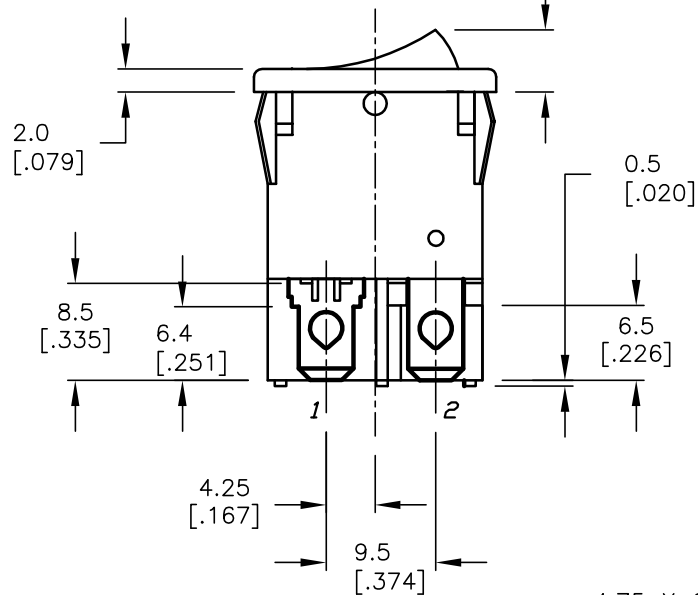

RECOMMENDED PANEL MOUNTING

NOT TO SCALE

PANEL THICKNESS	X
0.75-1.25 (.030-.049)	19.2 (.756)
1.25-2.0 (.049-.079)	19.4 (.764)

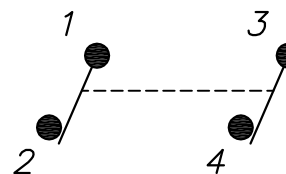

CIRCUIT: DPST

NOTES:

1. ALL DIMENSIONS IN MM [INCH]
2. GENERAL TOLERANCE: X.X=±0.4
X.XX=±0.25
3. TERM. NOS. FOR REF. ONLY
4. RATING: AC 125V 12A, AC 250V 8A
5. MECHANICAL LIFE: 15,000 cycles
6. ELECTRICAL LIFE: 10,000 cycles
7. CONTACT RESISTANCE: 10mILLI-Ohms
8. INSULATION RESISTANCE: >1000Mega-Ohms
9. DIELECTRIC STRENGTH: 1,500 Volts for 1min.
3,000 Volts between poles
10. OPERATING TEMP: -30°C to 85°C
- ▲ 11. HOUSING COLOR: BLACK
- ▲ 12. ACTUATOR COLOR: BLACK

C	13932	ADD 0 TO PART DESC.	4/16/04	AR
B	12538	REMOVED 0 FROM PART DESC.	11/5/02	CB
A	12286	RELEASED	9/24/02	CB
REV.	ECN No.	DESCRIPTION	DATE	CHKD

THE INFORMATION CONTAINED IN THIS DOCUMENT IS PROPRIETARY TO E-SWITCH AND IS NOT TO BE COPIED OR TRANSFERRED

E-SWITCH®

TITLE

RC1083BBLKBLKFF0

SCALE

1.5:1

DATE

9/24/02

DR

CB

DWG

P301508

REV

C