

FEATURES

- 10 MHz multiplying bandwidth
- INL of ± 0.25 LSB @ 8 bits
- 20-lead and 24-lead TSSOP packages
- 2.5 V to 5.5 V supply operation
- ± 10 V reference input
- 21.3 MSPS update rate
- Extended temperature range: -40°C to $+125^{\circ}\text{C}$
- 4-quadrant multiplication
- Power-on reset
- 0.5 μA typical current consumption
- Guaranteed monotonic
- Readback function
- AD7528 upgrade (AD5428)
- AD7547 upgrade (AD5447)

APPLICATIONS

- Portable battery-powered applications
- Waveform generators
- Analog processing
- Instrumentation applications
- Programmable amplifiers and attenuators
- Digitally controlled calibration
- Programmable filters and oscillators
- Composite video
- Ultrasound
- Gain, offset, and voltage trimming

GENERAL DESCRIPTION

The AD5428/AD5440/AD5447¹ are CMOS, 8-, 10-, and 12-bit, dual-channel, current output digital-to-analog converters (DACs), respectively. These devices operate from a 2.5 V to 5.5 V power supply, making them suited to battery-powered and other applications.

As a result of being manufactured on a CMOS submicron process, they offer excellent 4-quadrant multiplication characteristics, with large signal multiplying bandwidths of up to 10 MHz.

The DACs use data readback, allowing the user to read the contents of the DAC register via the DB pins. On power-up, the internal register and latches are filled with 0s, and the DAC outputs are at zero scale.

The applied external reference input voltage (V_{REF}) determines the full-scale output current. An integrated feedback resistor (R_{FB}) provides temperature tracking and full-scale voltage output when combined with an external I-to-V precision amplifier.

The AD5428 is available in a small 20-lead TSSOP package, and the AD5440/AD5447 DACs are available in small 24-lead TSSOP packages.

¹ U.S. Patent Number 5,689,257.

FUNCTIONAL BLOCK DIAGRAM

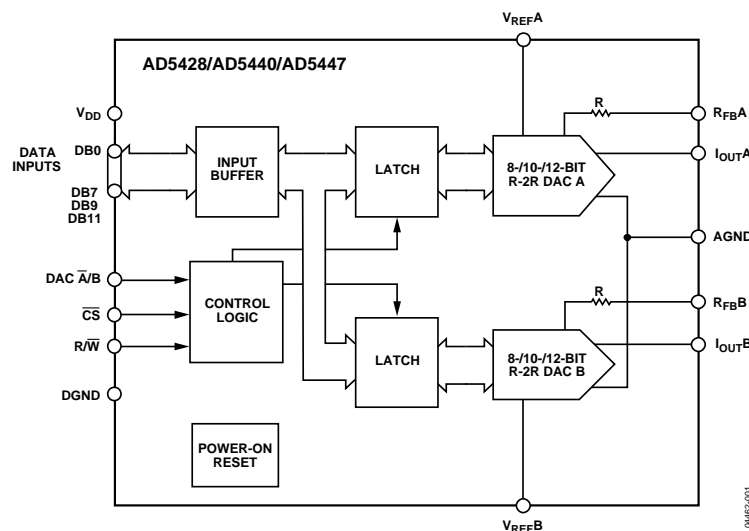

Figure 1. AD5428/AD5440/AD5447

Rev. B

Information furnished by Analog Devices is believed to be accurate and reliable. However, no responsibility is assumed by Analog Devices for its use, nor for any infringements of patents or other rights of third parties that may result from its use. Specifications subject to change without notice. No license is granted by implication or otherwise under any patent or patent rights of Analog Devices. Trademarks and registered trademarks are the property of their respective owners.

TABLE OF CONTENTS

Specifications.....	3	Divider or Programmable Gain Element.....	20
Timing Characteristics	5	Reference Selection	20
Absolute Maximum Ratings.....	6	Amplifier Selection	20
ESD Caution.....	6	Parallel Interface.....	22
Pin Configurations and Function Descriptions	7	Microprocessor Interfacing.....	22
Typical Performance Characteristics	10	PCB Layout and Power Supply Decoupling	23
Terminology	15	Evaluation Board for the DACs.....	23
General Description	16	Power Supplies for the Evaluation Board.....	23
DAC Section.....	16	Bill of Materials.....	27
Circuit Operation	16	Overview of AD54xx Devices.....	28
Single-Supply Applications	19	Outline Dimensions	29
Adding Gain.....	19	Ordering Guide	29

REVISION HISTORY

3/11—Rev. A to Rev. B

Changes to Evaluation Board For the AD5447 Section	23
Changes to Figure 47 Caption.....	24
Changes to Figure 49.....	25
Change to U1 Description in Table 12.....	27
Change to Ordering Guide.....	29

7/05—Rev. 0 to Rev. A

Changed Pin DAC A/B to DAC \bar{A}/\bar{B}	Universal
Changes to Features List	1
Changes to Specifications	3
Changes to Timing Characteristics	5
Change to Figure 2	5
Change to Absolute Maximum Ratings Section.....	6
Change to Figure 13, Figure 14, and Figure 18.....	11
Change to Figure 32 Through Figure 34	14
Changes to General Description Section	16
Changes to Figure 37.....	16

Changes to Single-Supply Applications Section.....	19
Changes to Figure 40 Through Figure 42.....	19
Changes to Divider or Programmable Gain Element Section....	20
Changes to Figure 43.....	20
Changes to Table 9 Through Table 11	21
Changes to Microprocessor Interfacing Section	22
Added Figure 44 Through Figure 46	22
Added 8xC51-to-AD5428/AD5440/AD5447	
Interface Section	22
Added ADSP-BF5xx-to-AD5428/AD5440/AD5447	
Interface Section	22
Changes to Power Supplies for the Evaluation Board Section....	23
Changes to Table 13	28
Updated Outline Dimensions.....	29
Changes to Ordering Guide.....	29

7/04—Revision 0: Initial Version

SPECIFICATIONS¹

$V_{DD} = 2.5\text{ V to }5.5\text{ V}$, $V_{REF} = 10\text{ V}$, $I_{OUT2} = 0\text{ V}$. Temperature range for Y version: $-40^{\circ}\text{C to }+125^{\circ}\text{C}$. All specifications T_{MIN} to T_{MAX} , unless otherwise noted. DC performance is measured with OP177, and ac performance is measured with AD8038, unless otherwise noted.

Table 1.

Parameter	Min	Typ	Max	Unit	Conditions
STATIC PERFORMANCE					
AD5428					
Resolution			8	Bits	Guaranteed monotonic
Relative Accuracy			± 0.25	LSB	
Differential Nonlinearity			± 1	LSB	
AD5440					
Resolution			10	Bits	Guaranteed monotonic
Relative Accuracy			± 0.5	LSB	
Differential Nonlinearity			± 1	LSB	
AD5447					
Resolution			12	Bits	Guaranteed monotonic
Relative Accuracy			± 1	LSB	
Differential Nonlinearity			$-1/+2$	LSB	
Gain Error			± 25	mV	
Gain Error Temperature Coefficient		± 5		ppm FSR/ $^{\circ}\text{C}$	
Output Leakage Current			± 5	nA	Data = 0x0000, $T_A = 25^{\circ}\text{C}$
			± 15	nA	Data = 0x0000
REFERENCE INPUT					
Reference Input Range		± 10		V	Input resistance TC = $-50\text{ ppm}/^{\circ}\text{C}$ Typ = 25°C , max = 125°C
V_{REFA} , V_{REFB} Input Resistance	8	10	13	k Ω	
V_{REFA} -to- V_{REFB} Input Resistance Mismatch		1.6	2.5	%	
Input Capacitance					
Code 0		3.5		pF	
Code 4095		3.5		pF	
DIGITAL INPUTS/OUTPUT					
Input High Voltage, V_{IH}	1.7			V	$V_{DD} = 3.6\text{ V to }5.5\text{ V}$
	1.7			V	$V_{DD} = 2.5\text{ V to }3.6\text{ V}$
Input Low Voltage, V_{IL}			0.8	V	$V_{DD} = 2.7\text{ V to }5.5\text{ V}$
			0.7	V	$V_{DD} = 2.5\text{ V to }2.7\text{ V}$
Output High Voltage, V_{OH}	$V_{DD} - 1$			V	$V_{DD} = 4.5\text{ V to }5.5\text{ V}$, $I_{SOURCE} = 200\text{ }\mu\text{A}$
	$V_{DD} - 0.5$			V	$V_{DD} = 2.5\text{ V to }3.6\text{ V}$, $I_{SOURCE} = 200\text{ }\mu\text{A}$
Output Low Voltage, V_{OL}			0.4	V	$V_{DD} = 4.5\text{ V to }5.5\text{ V}$, $I_{SINK} = 200\text{ }\mu\text{A}$
			0.4	V	$V_{DD} = 2.5\text{ V to }3.6\text{ V}$, $I_{SINK} = 200\text{ }\mu\text{A}$
Input Leakage Current, I_{IL}			1	μA	
Input Capacitance		4	10	pF	
DYNAMIC PERFORMANCE					
Reference-Multiplying BW		10		MHz	$V_{REF} = \pm 3.5\text{ V p-p}$, DAC loaded all 1s
Output Voltage Settling Time					$R_{LOAD} = 100\text{ }\Omega$, $C_{LOAD} = 15\text{ pF}$, $V_{REF} = 10\text{ V}$ DAC latch alternately loaded with 0s and 1s
Measured to $\pm 1\text{ mV}$ of FS		80	120	ns	
Measured to $\pm 4\text{ mV}$ of FS		35	70	ns	
Measured to $\pm 16\text{ mV}$ of FS		30	60	ns	
Digital Delay		20	40	ns	Interface delay time
10% to 90% Settling Time		15	30	ns	Rise and fall times, $V_{REF} = 10\text{ V}$, $R_{LOAD} = 100\text{ }\Omega$
Digital-to-Analog Glitch Impulse		3		nV-sec	1 LSB change around major carry, $V_{REF} = 0\text{ V}$

AD5428/AD5440/AD5447

Parameter	Min	Typ	Max	Unit	Conditions
Multiplying Feedthrough Error			70	dB	DAC latches loaded with all 0s, $V_{REF} = \pm 3.5$ V 1 MHz
			48	dB	10 MHz
Output Capacitance		12	17	pF	DAC latches loaded with all 0s
		25	30	pF	DAC latches loaded with all 1s
Digital Feedthrough		1		nV-sec	Feedthrough to DAC output with \overline{CS} high and alternate loading of all 0s and all 1s
Output Noise Spectral Density		25		nV/ $\sqrt{\text{Hz}}$	@ 1 kHz
Analog THD		81		dB	$V_{REF} = 3.5$ V p-p, all 1s loaded, $f = 100$ kHz
Digital THD					Clock = 10 MHz, $V_{REF} = 3.5$ V
100 kHz f_{OUT}		61		dB	
50 kHz f_{OUT}		66		dB	
SFDR Performance (Wide Band)					AD5447, 65k codes, $V_{REF} = 3.5$ V
Clock = 10 MHz					
500 kHz f_{OUT}		55		dB	
100 kHz f_{OUT}		63		dB	
50 kHz f_{OUT}		65		dB	
Clock = 25 MHz					
500 kHz f_{OUT}		50		dB	
100 kHz f_{OUT}		60		dB	
50 kHz f_{OUT}		62		dB	
SFDR Performance (Narrow Band)					AD5447, 65k codes, $V_{REF} = 3.5$ V
Clock = 10 MHz					
500 kHz f_{OUT}		73		dB	
100 kHz f_{OUT}		80		dB	
50k Hz f_{OUT}		87		dB	
Clock = 25 MHz					
500 kHz f_{OUT}		70		dB	
100 kHz f_{OUT}		75		dB	
50 kHz f_{OUT}		80		dB	
Intermodulation Distortion					AD5447, 65k codes, $V_{REF} = 3.5$ V
$f_1 = 40$ kHz, $f_2 = 50$ kHz		72		dB	Clock = 10 MHz
$f_1 = 40$ kHz, $f_2 = 50$ kHz		65		dB	Clock = 25 MHz
POWER REQUIREMENTS					
Power Supply Range	2.5		5.5	V	
I_{DD}			0.7	μA	$T_A = 25^\circ\text{C}$, logic inputs = 0 V or V_{DD}
		0.5	10	μA	$T_A = -40^\circ\text{C}$ to $+125^\circ\text{C}$, logic inputs = 0 V or V_{DD}
Power Supply Sensitivity			0.001	%/%	$\Delta V_{DD} = \pm 5\%$

¹ Guaranteed by design, not subject to production test.

TIMING CHARACTERISTICS

All input signals are specified with $t_r = t_f = 1 \text{ ns}$ (10% to 90% of V_{DD}) and timed from a voltage level of $(V_{IL} + V_{IH})/2$. $V_{DD} = 2.5 \text{ V}$ to 5.5 V , $V_{REF} = 10 \text{ V}$, $I_{OUT2} = 0 \text{ V}$, temperature range for Y version: -40°C to $+125^\circ\text{C}$. All specifications T_{MIN} to T_{MAX} unless otherwise noted.

Table 2.

Parameter ¹	Limit at T_{MIN} , T_{MAX}	Unit	Conditions/Comments
Write Mode			
t_1	0	ns min	R/\bar{W} to \bar{CS} setup time
t_2	0	ns min	R/\bar{W} to \bar{CS} hold time
t_3	10	ns min	\bar{CS} low time
t_4	10	ns min	Address setup time
t_5	0	ns min	Address hold time
t_6	6	ns min	Data setup time
t_7	0	ns min	Data hold time
t_8	5	ns min	R/\bar{W} high to \bar{CS} low
t_9	7	ns min	\bar{CS} min high time
Data Readback Mode			
t_{10}	0	ns typ	Address setup time
t_{11}	0	ns typ	Address hold time
t_{12}	5	ns typ	Data access time
	25	ns max	
t_{13}	5	ns typ	Bus relinquish time
	10	ns max	
Update Rate	21.3	MSPS	Consists of \bar{CS} min high time, \bar{CS} low time, and output voltage settling time

¹ Guaranteed by design and characterization, not subject to production test.

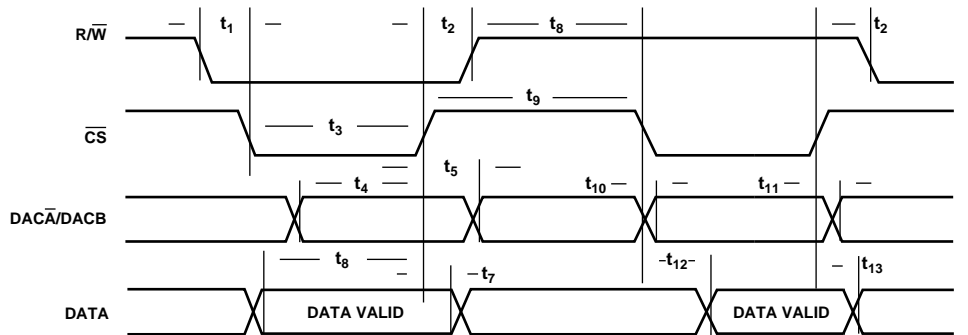

Figure 2. Timing Diagram

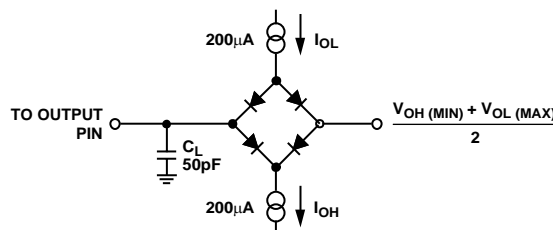

Figure 3. Load Circuit for Data Output Timing Specifications

ABSOLUTE MAXIMUM RATINGS

Transient currents of up to 100 mA do not cause SCR latch-up.

$T_A = 25^\circ\text{C}$, unless otherwise noted.

Table 3.

Parameter	Rating
V_{DD} to GND	-0.3 V to +7 V
V_{REFA} , V_{REFB} , R_{FBA} , R_{FBB} to DGND	-12 V to +12 V
I_{OUT1} , I_{OUT2} to DGND	-0.3 V to +7 V
Logic Inputs and Output ¹	-0.3 V to $V_{DD} + 0.3$ V
Operating Temperature Range	
Automotive (Y Version)	-40°C to +125°C
Storage Temperature Range	-65°C to +150°C
Junction Temperature	150°C
20-lead TSSOP θ_{JA} Thermal Impedance	143°C/W
24-lead TSSOP θ_{JA} Thermal Impedance	128°C/W
Lead Temperature, Soldering (10 sec)	300°C
IR Reflow, Peak Temperature (<20 sec)	235°C

¹Overvoltages at \overline{DBx} , \overline{CS} , and R/\overline{W} are clamped by internal diodes.

Stresses above those listed in Absolute Maximum Ratings may cause permanent damage to the device. This is a stress rating only; functional operation of the device at these or any other conditions above those listed in the operational sections of this specification is not implied. Exposure to absolute maximum rating conditions for extended periods may affect device reliability. Only one absolute maximum rating may be applied at any one time.

ESD CAUTION

ESD (electrostatic discharge) sensitive device. Electrostatic charges as high as 4000 V readily accumulate on the human body and test equipment and can discharge without detection. Although this product features proprietary ESD protection circuitry, permanent damage may occur on devices subjected to high energy electrostatic discharges. Therefore, proper ESD precautions are recommended to avoid performance degradation or loss of functionality.



PIN CONFIGURATIONS AND FUNCTION DESCRIPTIONS

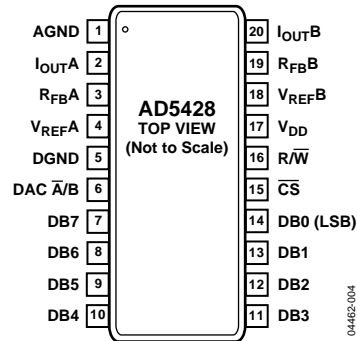

Figure 4. Pin Configuration 20-Lead TSSOP (RU-20)

Table 4. AD5428 Pin Function Descriptions

Pin No.	Mnemonic	Description
1	AGND	DAC Ground Pin. This pin should typically be tied to the analog ground of the system, but can be biased to achieve single-supply operation.
2, 20	I_{OUTA} , I_{OUTB}	DAC Current Outputs.
3, 19	R_{FBA} , R_{FBB}	DAC Feedback Resistor Pins. These pins establish voltage output for the DAC by connecting to an external amplifier output.
4, 18	V_{REFA} , V_{REFB}	DAC Reference Voltage Input Terminals.
5	DGND	Digital Ground Pin.
6	DAC \bar{A}/B	Selects DAC A or DAC B. Low selects DAC A; high selects DAC B.
7 to 14	DB7 to DB0	Parallel Data Bits 7 Through 0.
15	\bar{CS}	Chip Select Input. Active low. Used in conjunction with \bar{R}/\bar{W} to load parallel data to the input latch or to read data from the DAC register.
16	\bar{R}/\bar{W}	Read/Write. When low, used in conjunction with \bar{CS} to load parallel data. When high, used in conjunction with \bar{CS} to read back contents of the DAC register.
17	V_{DD}	Positive Power Supply Input. This part can be operated from a supply of 2.5 V to 5.5 V.

AD5428/AD5440/AD5447

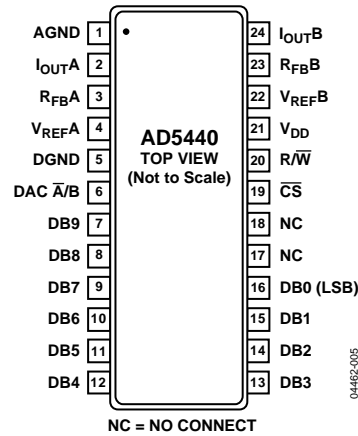

Figure 5. Pin Configuration 24-Lead TSSOP (RU-24)

Table 5. AD5440 Pin Function Descriptions

Pin No.	Mnemonic	Function
1	AGND	DAC Ground Pin. This pin should typically be tied to the analog ground of the system, but can be biased to achieve single-supply operation.
2, 24	I _{OUTA} , I _{OUTB}	DAC Current Outputs.
3, 23	R _{FBA} , R _{FBB}	DAC Feedback Resistor Pins. Establish voltage output for the DAC by connecting to an external amplifier output.
4, 22	V _{REF A} , V _{REF B}	DAC Reference Voltage Input Terminals.
5	DGND	Digital Ground Pin.
6	DAC \bar{A}/\bar{B}	Selects DAC A or DAC B. Low selects DAC A; high selects DAC B.
7 to 16	DB9 to DB0	Parallel Data Bits 9 Through 0.
19	\overline{CS}	Chip Select Input. Active low. Used in conjunction with $\overline{R/\bar{W}}$ to load parallel data to the input latch or to read data from the DAC register.
20	$\overline{R/\bar{W}}$	Read/Write. When low, used in conjunction with \overline{CS} to load parallel data. When high, used in conjunction with \overline{CS} to read back contents of the DAC register.
21	V _{DD}	Positive Power Supply Input. This part can be operated from a supply of 2.5 V to 5.5 V.

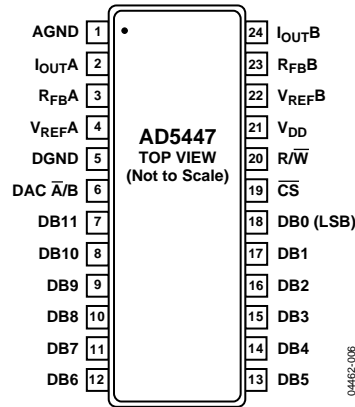

Figure 6. Pin Configuration 24-Lead TSSOP (RU-24)

Table 6. AD5447 Pin Function Descriptions

Pin No.	Mnemonic	Description
1	AGND	DAC Ground Pin. This pin should typically be tied to the analog ground of the system, but can be biased to achieve single-supply operation.
2, 24	I_{OUTA} , I_{OUTB}	DAC Current Outputs.
3, 23	R_{FBA} , R_{FBB}	DAC Feedback Resistor Pins. Establish voltage output for the DAC by connecting to an external amplifier output.
4, 22	V_{REFA} , V_{REFB}	DAC Reference Voltage Input Terminals.
5	DGND	Digital Ground Pin.
6	DAC $\overline{A/B}$	Selects DAC A or DAC B. Low selects DAC A; high selects DAC B.
7 to 18	DB11 to DB0	Parallel Data Bits 11 Through 0.
19	\overline{CS}	Chip Select Input. Active low. Used in conjunction with $\overline{R/W}$ to load parallel data to the input latch or to read data from the DAC register. When \overline{CS} and $\overline{R/W}$ are held low, the latches are transparent. Any changes on the data lines are reflected in the relevant DAC output.
20	$\overline{R/W}$	Read/Write. When low, used in conjunction with \overline{CS} to load parallel data. When high, used in conjunction with \overline{CS} to read back the contents of the DAC register. When \overline{CS} and $\overline{R/W}$ are held low, the latches are transparent. Any changes on the data lines are reflected in the relevant DAC output.
21	V_{DD}	Positive Power Supply Input. This part can be operated from a supply of 2.5 V to 5.5 V.

TYPICAL PERFORMANCE CHARACTERISTICS

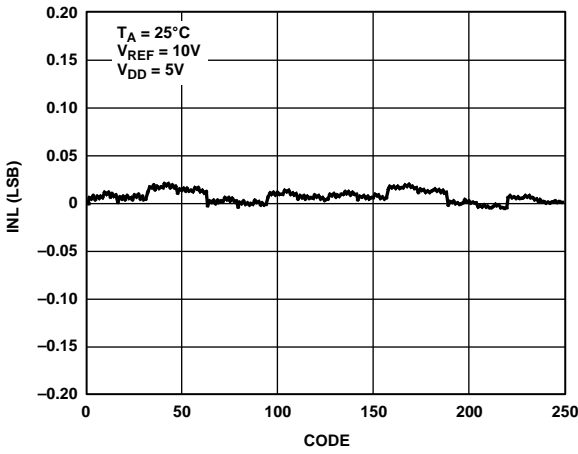

Figure 7. INL vs. Code (8-Bit DAC)

04462-007

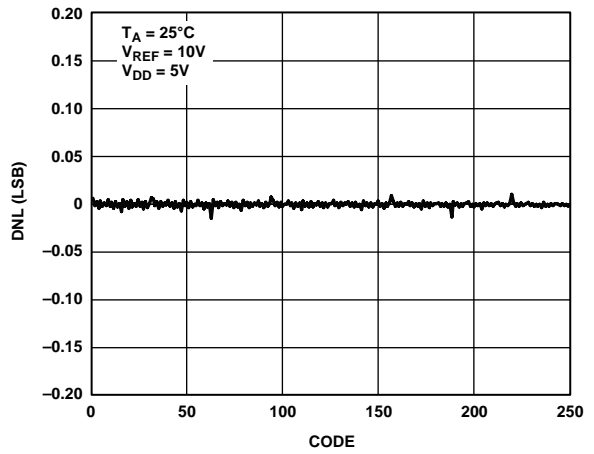

Figure 10. DNL vs. Code (8-Bit DAC)

04462-010

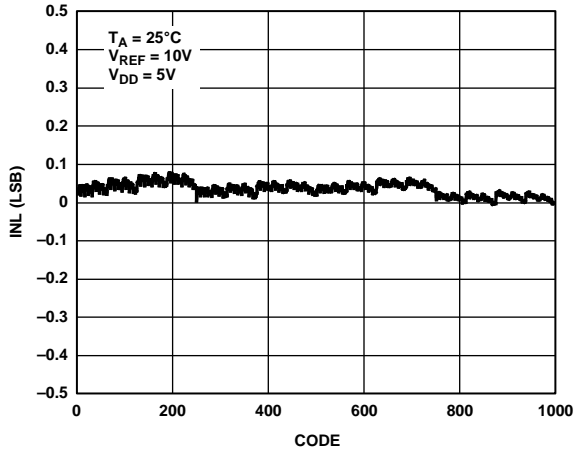

Figure 8. INL vs. Code (10-Bit DAC)

04462-008

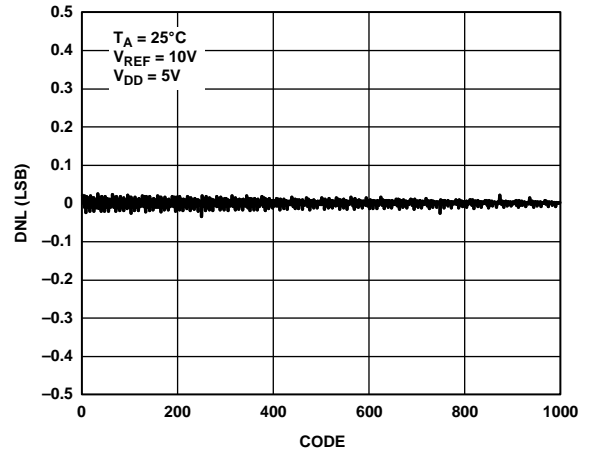

Figure 11. DNL vs. Code (10-Bit DAC)

04462-011

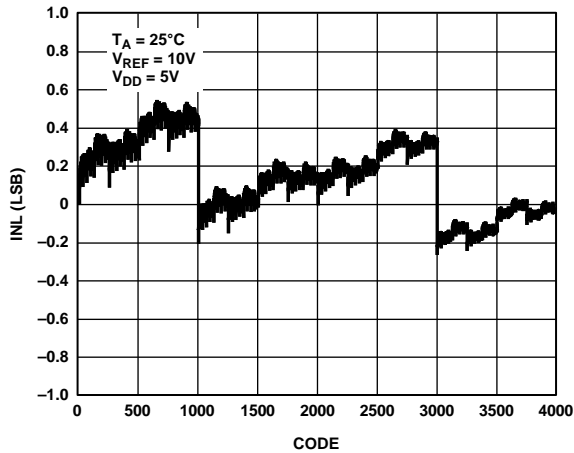

Figure 9. INL vs. Code (12-Bit DAC)

04462-009

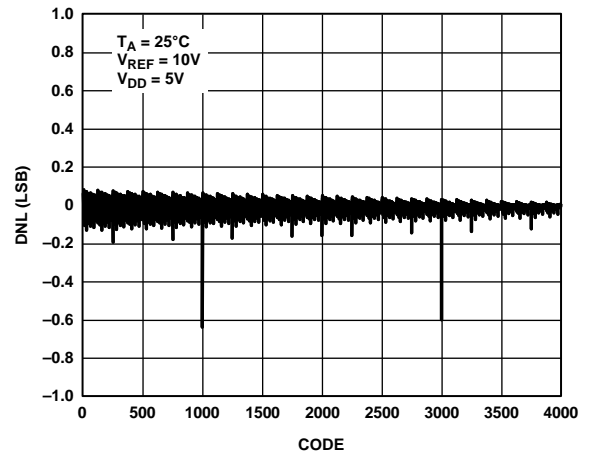

Figure 12. DNL vs. Code (12-Bit DAC)

04462-012

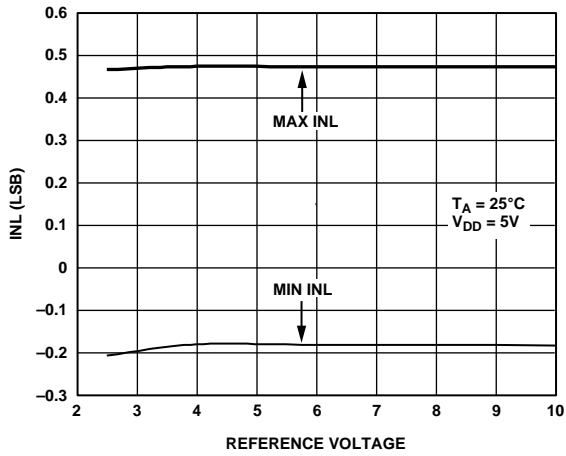

Figure 13. INL vs. Reference Voltage

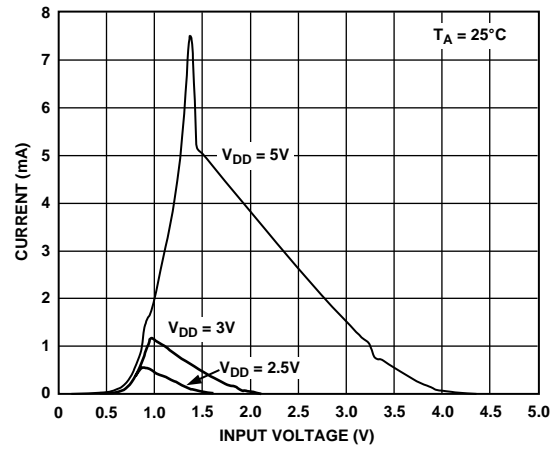

Figure 16. Supply Current vs. Logic Input Voltage

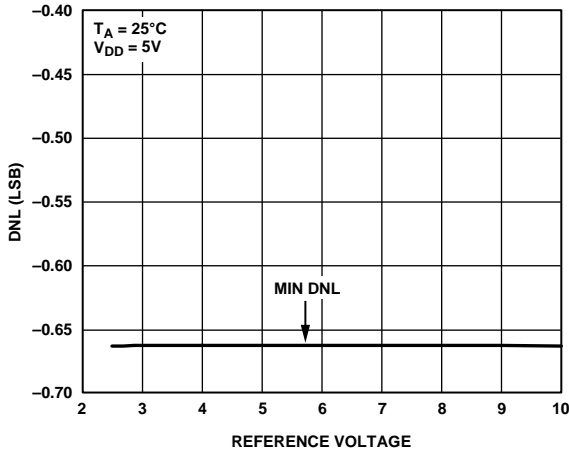

Figure 14. DNL vs. Reference Voltage

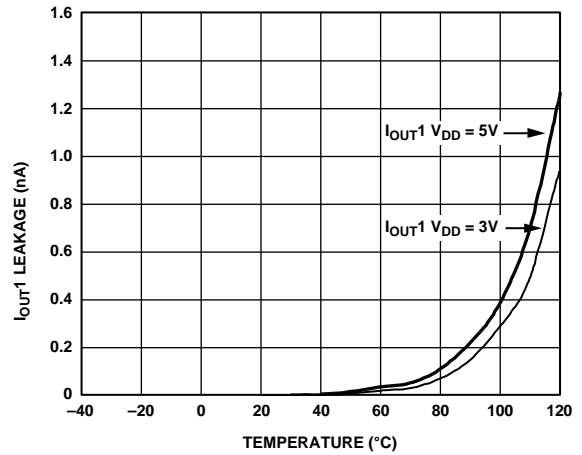

Figure 17. I_{OUT1} Leakage Current vs. Temperature

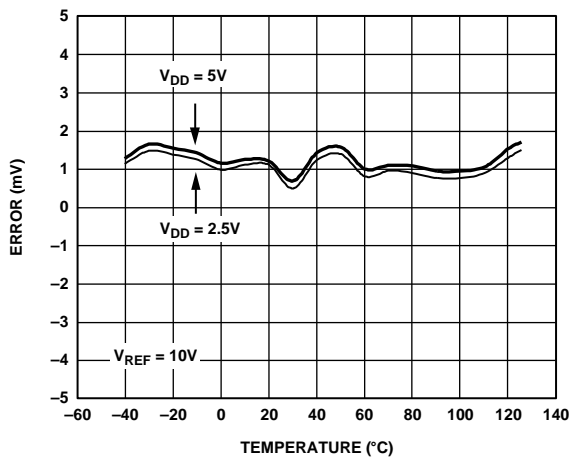

Figure 15. Gain Error vs. Temperature

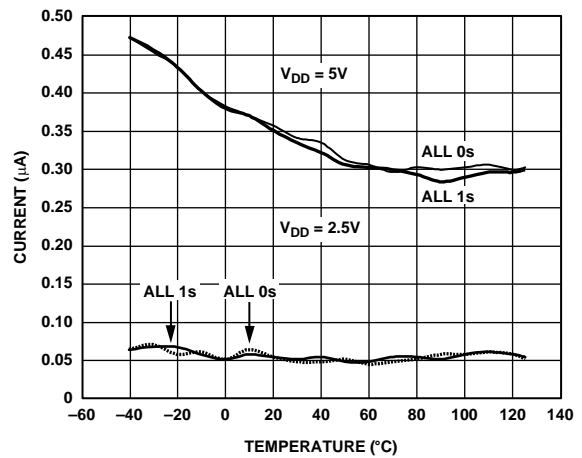

Figure 18. Supply Current vs. Temperature

04462-013

04462-022

04462-014

04462-023

04462-015

04462-024

AD5428/AD5440/AD5447

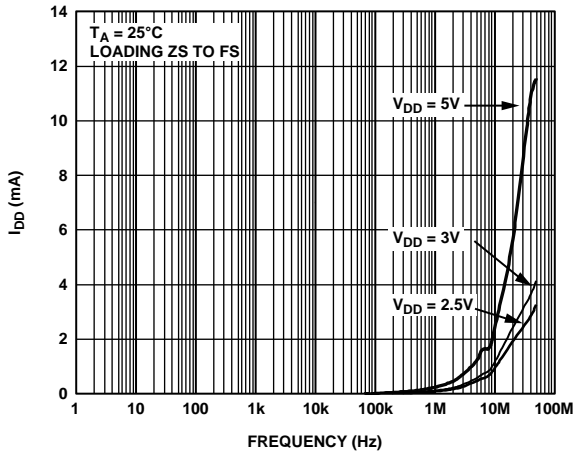

Figure 19. Supply Current vs. Update Rate

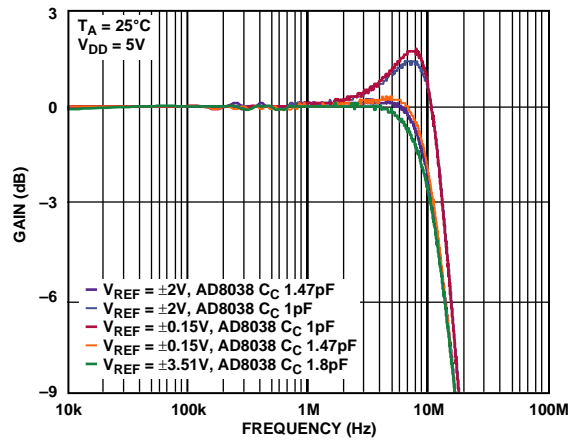

Figure 22. Reference Multiplying Bandwidth vs. Frequency and Compensation Capacitor

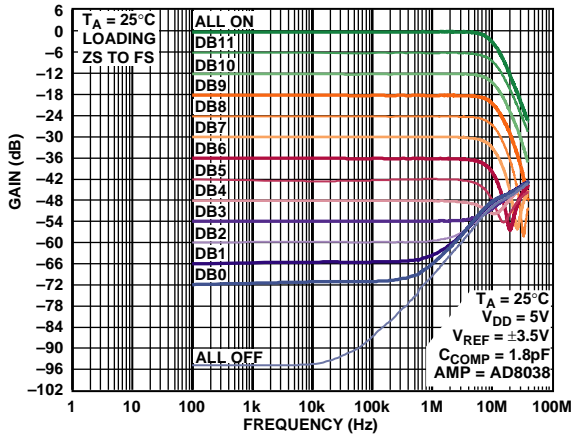

Figure 20. Reference Multiplying Bandwidth vs. Frequency and Code

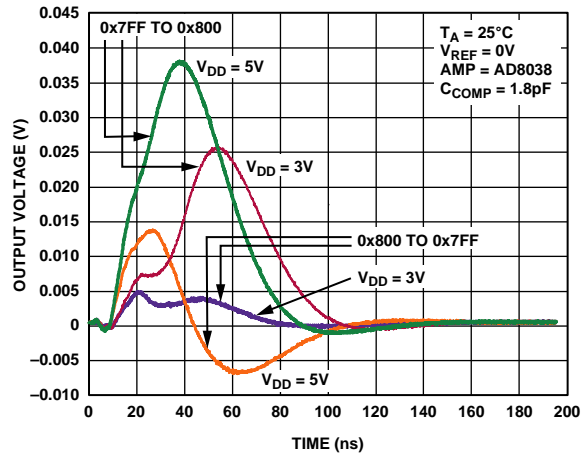

Figure 23. Midscale Transition, $V_{REF} = 0\text{ V}$

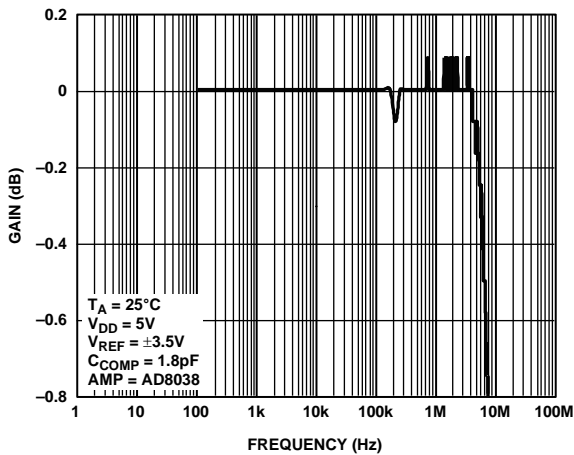

Figure 21. Reference Multiplying Bandwidth—All 1s Loaded

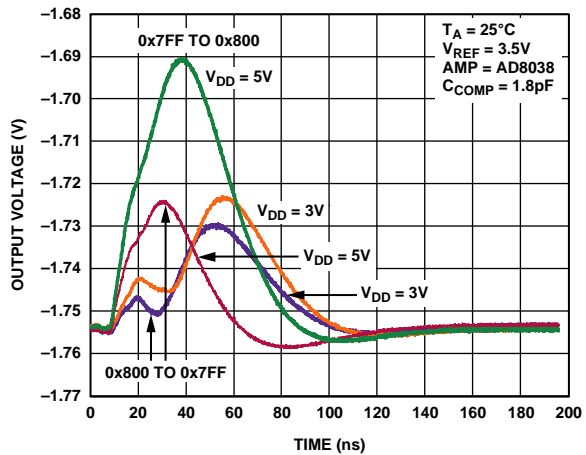

Figure 24. Midscale Transition, $V_{REF} = 3.5\text{ V}$

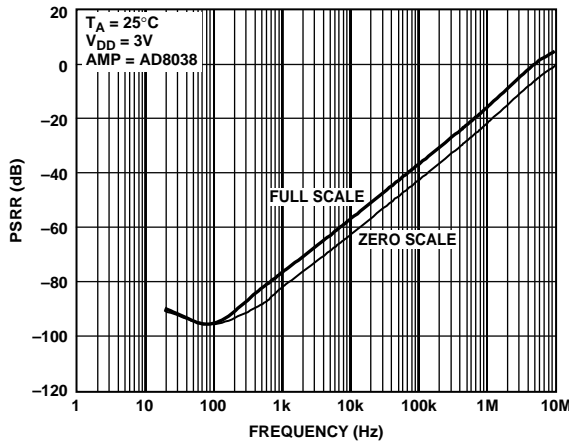

Figure 25. Power Supply Rejection Ratio vs. Frequency

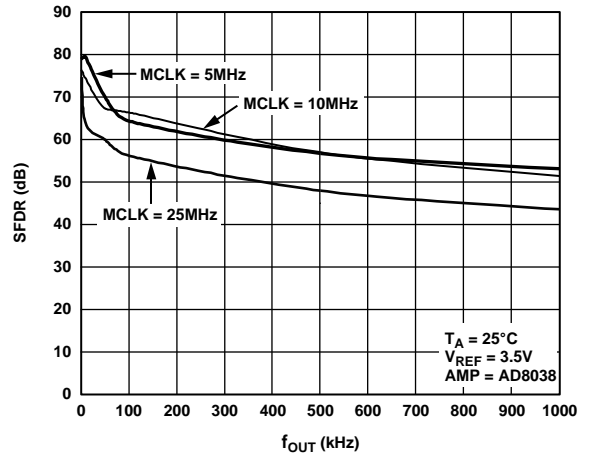

Figure 28. Wideband SFDR vs. f_{OUT} Frequency

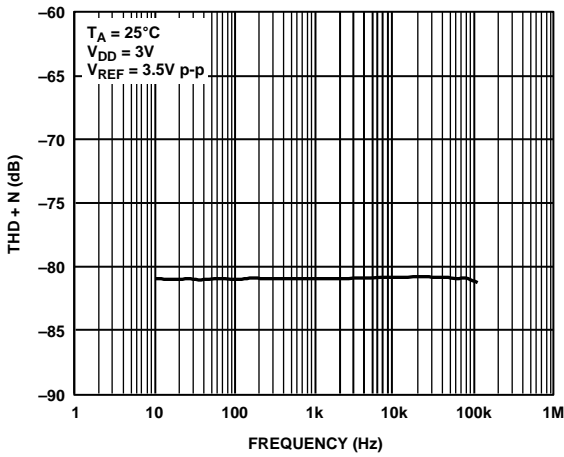

Figure 26. THD + Noise vs. Frequency

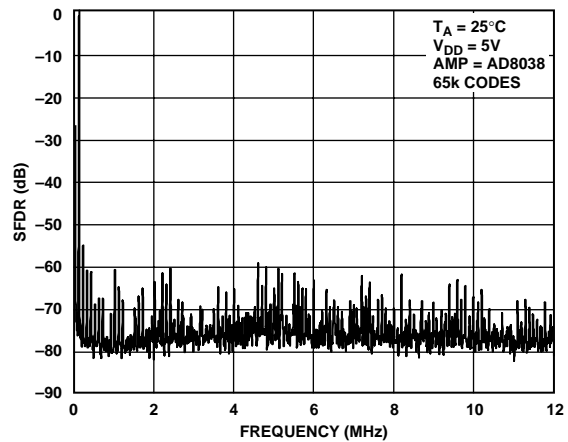

Figure 29. Wideband SFDR, $f_{OUT} = 100$ kHz, Clock = 25 MHz

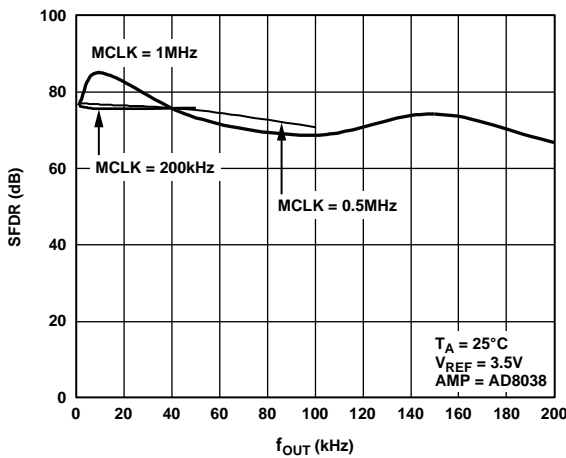

Figure 27. Wideband SFDR vs. f_{OUT} Frequency

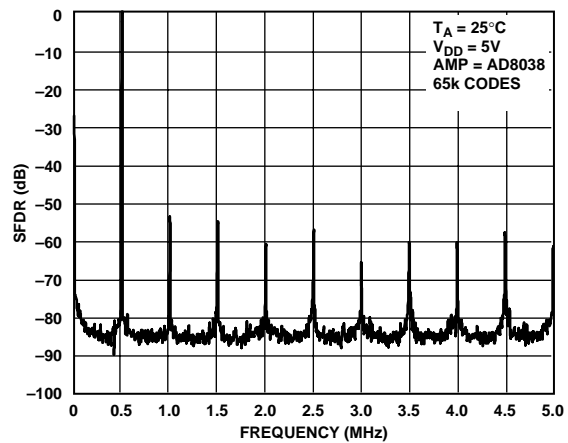

Figure 30. Wideband SFDR, $f_{OUT} = 500$ kHz, Clock = 10 MHz

AD5428/AD5440/AD5447

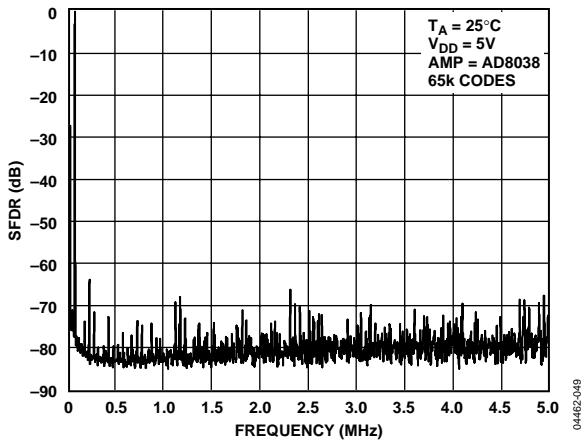

Figure 31. Wideband SFDR, $f_{OUT} = 50$ kHz, Clock = 10 MHz

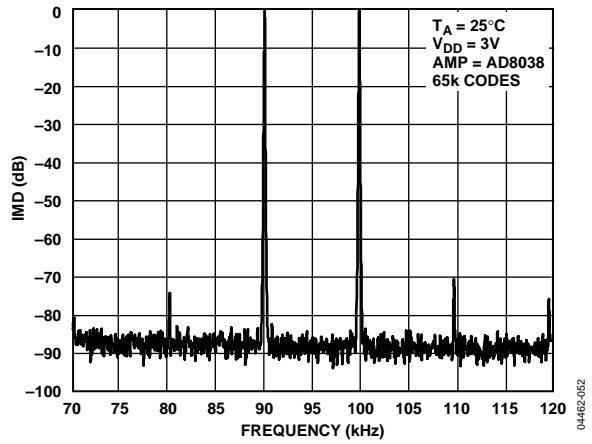

Figure 34. Narrow-Band IMD, $f_{OUT} = 90$ kHz, 100 kHz, Clock = 10 MHz

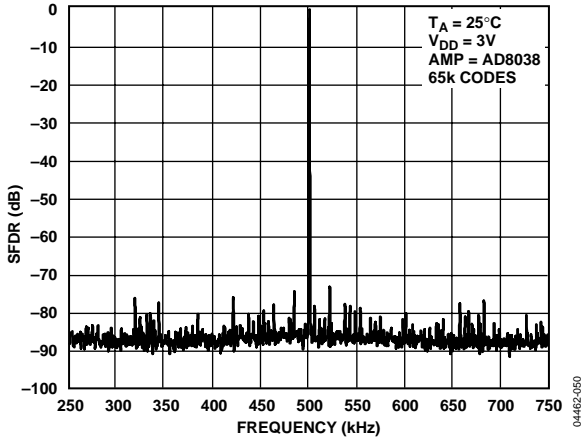

Figure 32. Narrow-Band SFDR, $f_{OUT} = 500$ kHz, Clock = 25 MHz

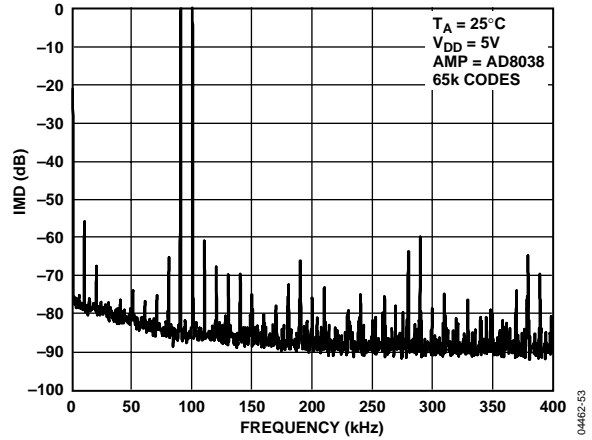

Figure 35. Wideband IMD, $f_{OUT} = 90$ kHz, 100 kHz, Clock = 25 MHz

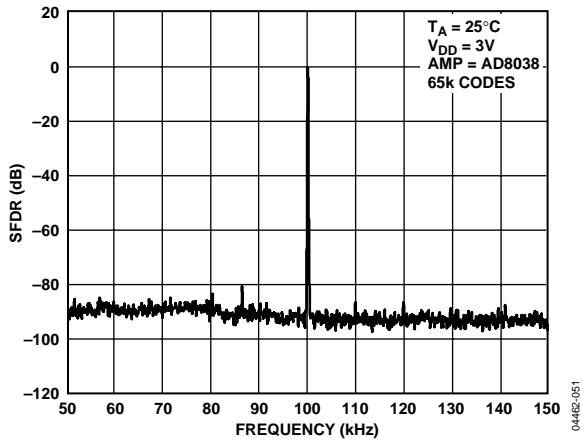

Figure 33. Narrow-Band SFDR, $f_{OUT} = 100$ kHz, Clock = 25 MHz

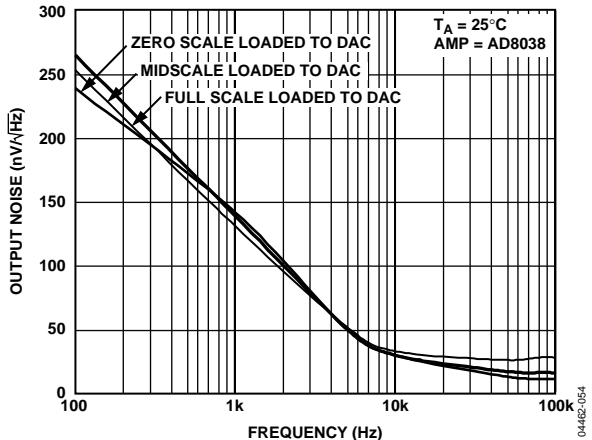

Figure 36. Output Noise Spectral Density

TERMINOLOGY

Relative Accuracy (Endpoint Nonlinearity)

A measure of the maximum deviation from a straight line passing through the endpoints of the DAC transfer function. It is measured after adjusting for zero and full scale and is typically expressed in LSBs or as a percentage of the full-scale reading.

Differential Nonlinearity

The difference in the measured change and the ideal 1 LSB change between two adjacent codes. A specified differential nonlinearity of -1 LSB maximum over the operating temperature range ensures monotonicity.

Gain Error (Full-Scale Error)

A measure of the output error between an ideal DAC and the actual device output. For these DACs, ideal maximum output is $V_{REF} - 1$ LSB. The gain error of the DACs is adjustable to zero with an external resistance.

Output Leakage Current

The current that flows into the DAC ladder switches when they are turned off. For the I_{OUT1} terminal, it can be measured by loading all 0s to the DAC and measuring the I_{OUT1} current. Minimum current flows into the I_{OUT2} line when the DAC is loaded with all 1s.

Output Capacitance

Capacitance from I_{OUT1} or I_{OUT2} to AGND.

Output Current Settling Time

The amount of time for the output to settle to a specified level for a full-scale input change. For these devices, it is specified with a $100\ \Omega$ resistor to ground.

Digital-to-Analog Glitch Impulse

The amount of charge injected from the digital inputs to the analog output when the inputs change state. This is normally specified as the area of the glitch in either pA-sec or nV-sec, depending on whether the glitch is measured as a current or voltage signal.

Digital Feedthrough

When the device is not selected, high frequency logic activity on the device's digital inputs is capacitively coupled through the device and produces noise on the I_{OUT} pins and, subsequently, on the following circuitry. This noise is digital feedthrough.

Multiplying Feedthrough Error

The error due to capacitive feedthrough from the DAC reference input to the DAC I_{OUT1} terminal when all 0s are loaded to the DAC.

Total Harmonic Distortion (THD)

The DAC is driven by an ac reference. The ratio of the rms sum of the harmonics of the DAC output to the fundamental value is the THD. Usually only the lower-order harmonics are included, such as second to fifth harmonics.

$$THD = 20 \log \frac{\sqrt{V_2^2 + V_3^2 + V_4^2 + V_5^2}}{V_1}$$

Digital Intermodulation Distortion

Second-order intermodulation distortion (IMD) measurements are the relative magnitude of the f_a and f_b tones digitally generated by the DAC and the second-order products at $2f_a - f_b$ and $2f_b - f_a$.

Spurious-Free Dynamic Range (SFDR)

SFDR is the usable dynamic range of a DAC before spurious noise interferes or distorts the fundamental signal. SFDR is the measure of difference in amplitude between the fundamental and the largest harmonic or nonharmonic spur from dc to full Nyquist bandwidth (half the DAC sampling rate, or $fs/2$). Narrow-band SFDR is a measure of SFDR over an arbitrary window size, in this case 50%, of the fundamental. Digital SFDR is a measure of the usable dynamic range of the DAC when the signal is a digitally generated sine wave.

GENERAL DESCRIPTION

DAC SECTION

The AD5428/AD5440/AD5447 are CMOS 8-, 10-, and 12-bit, dual-channel, current output DACs consisting of a standard inverting R-2R ladder configuration. Figure 37 shows a simplified diagram for a single channel of the 8-bit AD5428. The feedback resistor $R_{FB,A}$ has a value of R . The value of R is typically 10 k Ω (with a minimum of 8 k Ω and a maximum of 12 k Ω). If I_{OUT1} and AGND are kept at the same potential, a constant current flows into each ladder leg, regardless of digital input code. Therefore, the input resistance presented at $V_{REF,A}$ is always constant and nominally of value R . The DAC output (I_{OUT}) is code-dependent, producing various resistances and capacitances. When choosing an external amplifier, take into account the variation in impedance generated by the DAC on the amplifier's inverting input node.

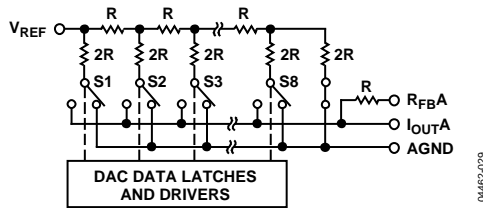

Figure 37. Simplified Ladder

Access is provided to the V_{REF} , R_{FB} , and I_{OUT} terminals of DAC A and DAC B, making the devices extremely versatile and allowing them to be configured in several operating modes, such as unipolar output mode, 4-quadrant multiplication bipolar mode, or single-supply mode. Note that a matching switch is used in series with the internal $R_{FB,A}$ feedback resistor. If users attempt to measure $R_{FB,A}$, power must be applied to V_{DD} to achieve continuity.

CIRCUIT OPERATION

Unipolar Mode

Using a single op amp, these devices can easily be configured to provide 2-quadrant multiplying operation or a unipolar output voltage swing, as shown in Figure 38. When an output amplifier is connected in unipolar mode, the output voltage is given by

$$V_{OUT} = -V_{REF} \times D/2^n$$

where:

D is the fractional representation of the digital word loaded to the DAC.

$$D = 0 \text{ to } 255 \text{ (8-bit AD5428)}$$

$$= 0 \text{ to } 1023 \text{ (10-bit AD5440)}$$

$$= 0 \text{ to } 4095 \text{ (12-bit AD5447)}$$

n is the resolution of the DAC.

Note that the output voltage polarity is opposite to the V_{REF} polarity for dc reference voltages. These DACs are designed to operate with either negative or positive reference voltages. The V_{DD} power pin is only used by the internal digital logic to drive the on and off states of the DAC switches.

These DACs are also designed to accommodate ac reference input signals in the range of -10 V to $+10$ V.

With a fixed 10 V reference, the circuit in Figure 38 gives a unipolar 0 V to -10 V output voltage swing. When V_{IN} is an ac signal, the circuit performs 2-quadrant multiplication.

Table 7 shows the relationship between digital code and the expected output voltage for unipolar operation using the 8-bit AD5428.

Table 7. Unipolar Code

Digital Input	Analog Output (V)
1111 1111	$-V_{REF} (255/256)$
1000 0000	$-V_{REF}(128/256) = -V_{REF}/2$
0000 0001	$-V_{REF} (1/256)$
0000 0000	$-V_{REF} (0/256) = 0$

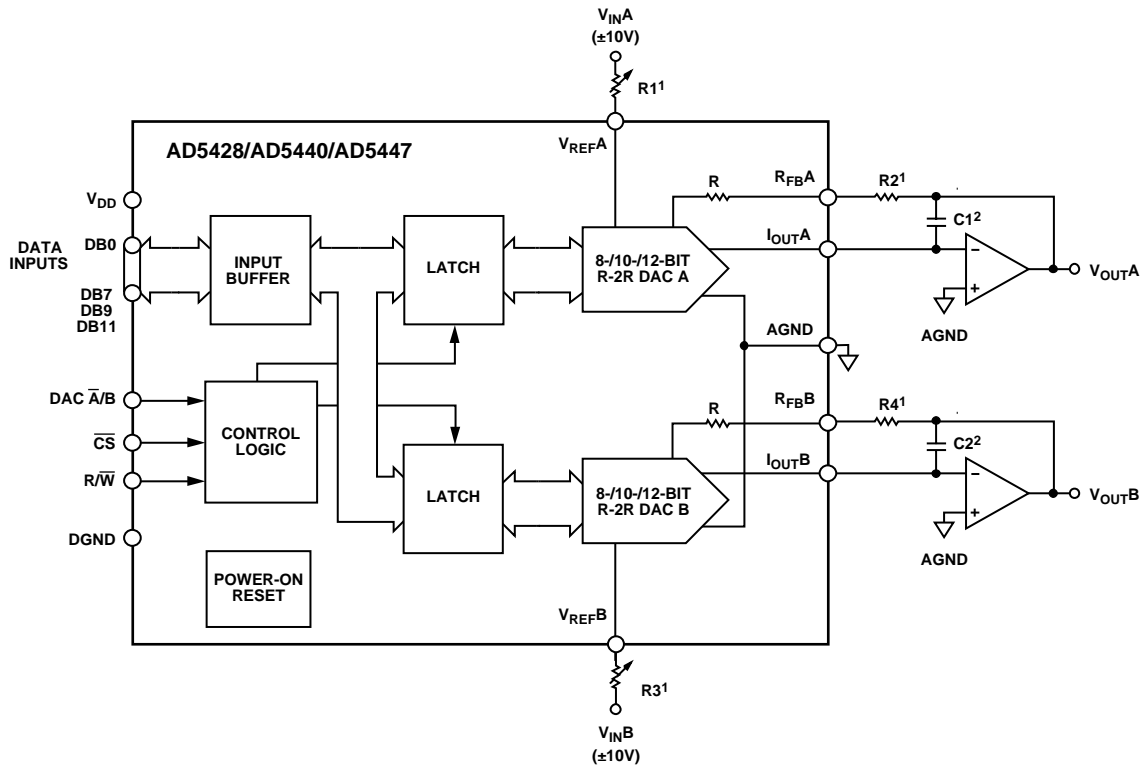

¹R1, R2 AND R3, R4 USED ONLY IF GAIN ADJUSTMENT IS REQUIRED.
²C1, C2 PHASE COMPENSATION (1pF TO 2pF) IS REQUIRED WHEN USING HIGH SPEED AMPLIFIERS TO PREVENT RINGING OR OSCILLATION.

04462-030

Figure 38. Unipolar Operation

AD5428/AD5440/AD5447

Bipolar Operation

In some applications, it may be necessary to generate full 4-quadrant multiplying operation or a bipolar output swing. This can easily be accomplished by using another external amplifier and some external resistors, as shown in Figure 39. In this circuit, the second amplifier, A2, provides a gain of 2. Biasing the external amplifier with an offset from the reference voltage results in full 4-quadrant multiplying operation. The transfer function of this circuit shows that both negative and positive output voltages are created as the input data (D) is incremented from Code 0 ($V_{OUT} = -V_{REF}$) to midscale ($V_{OUT} = 0$ V) to full scale ($V_{OUT} = +V_{REF}$).

When connected in bipolar mode, the output voltage is given by

$$V_{OUT} = (V_{REF} \times D / 2^{n-1}) - V_{REF}$$

where:

D is the fractional representation of the digital word loaded to the DAC.

- D = 0 to 255 (AD5428)
- = 0 to 1023 (AD5440)
- = 0 to 4095 (AD5447)

n is the number of bits.

When V_{IN} is an ac signal, the circuit performs 4-quadrant multiplication. Table 8 shows the relationship between digital code and the expected output voltage for bipolar operation using the 8-bit AD5428.

Table 8. Bipolar Code

Digital Input	Analog Output (V)
1111 1111	+ V_{REF} (127/128)
1000 0000	0
0000 0001	- V_{REF} (127/128)
0000 0000	- V_{REF} (128/128)

Stability

In the I-to-V configuration, the I_{OUT} of the DAC and the inverting node of the op amp must be connected as close as possible, and proper PCB layout techniques must be used. Because every code change corresponds to a step function, gain peaking may occur if the op amp has limited gain bandwidth product (GBP) and there is excessive parasitic capacitance at the inverting node. This parasitic capacitance introduces a pole into the open-loop response, which can cause ringing or instability in the closed-loop applications circuit.

An optional compensation capacitor, C1, can be added in parallel with $R_{FB}A$ for stability, as shown in Figure 38 and Figure 39. Too small a value of C1 can produce ringing at the output, whereas too large a value can adversely affect the settling time. C1 should be found empirically, but 1 pF to 2 pF is generally adequate for the compensation.

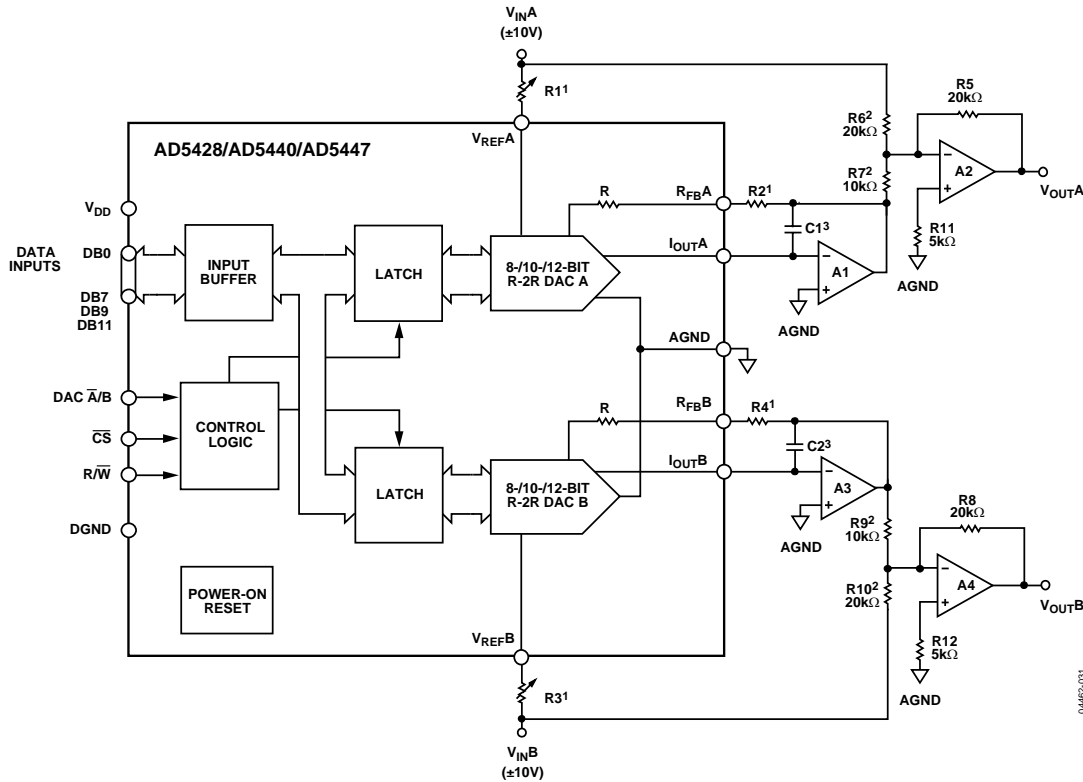

¹R1, R2 AND R3, R4 USED ONLY IF GAIN ADJUSTMENT IS REQUIRED. ADJUST R1 FOR $V_{OUTA} = 0$ V WITH CODE 10000000 IN DAC A LATCH. ADJUST R3 FOR $V_{OUTB} = 0$ V WITH CODE 10000000 IN DAC B LATCH.
²MATCHING AND TRACKING IS ESSENTIAL FOR RESISTOR PAIRS R6, R7 AND R9, R10.
³C1, C2 PHASE COMPENSATION (1pF TO 2pF) MAY BE REQUIRED IF A1/A3 IS A HIGH SPEED AMPLIFIER.

Figure 39. Bipolar Operation (4-Quadrant Multiplication)

SINGLE-SUPPLY APPLICATIONS
Voltage-Switching Mode

Figure 40 shows the DACs operating in voltage-switching mode. The reference voltage, V_{IN} , is applied to the I_{OUTA} pin, and the output voltage is available at the V_{REFA} terminal. In this configuration, a positive reference voltage results in a positive output voltage, making single-supply operation possible. The output from the DAC is voltage at constant impedance (the DAC ladder resistance). Therefore, an op amp is necessary to buffer the output voltage. The reference input no longer sees constant input impedance, but one that varies with code. Therefore, the voltage input should be driven from a low impedance source.

Note that V_{IN} is limited to low voltages because the switches in the DAC ladder no longer have the same source-drain drive voltage. As a result, their on resistance differs and degrades the integral linearity of the DAC. Also, V_{IN} must not go negative by more than 0.3 V, or an internal diode turns on, causing the device to exceed the maximum ratings. In this type of application, the full range of multiplying capability of the DAC is lost.

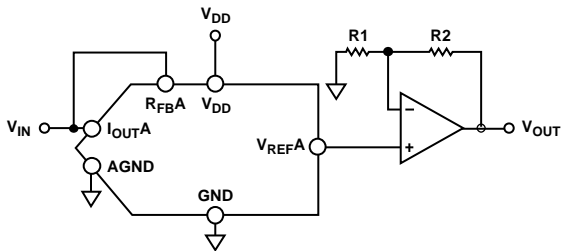

- NOTES**
 1. ADDITIONAL PINS OMITTED FOR CLARITY.
 2. C1 PHASE COMPENSATION (1pF TO 2pF) MAY BE REQUIRED IF A1 IS A HIGH SPEED AMPLIFIER.

Figure 40. Single-Supply Voltage-Switching Mode

Positive Output Voltage

The output voltage polarity is opposite to the V_{REF} polarity for dc reference voltages. To achieve a positive voltage output, an applied negative reference to the input of the DAC is preferred over the output inversion through an inverting amplifier because of the resistor's tolerance errors. To generate a negative reference, the reference can be level-shifted by an op amp such that the V_{OUT} and GND pins of the reference become the virtual ground and -2.5 V, respectively, as shown in Figure 41.

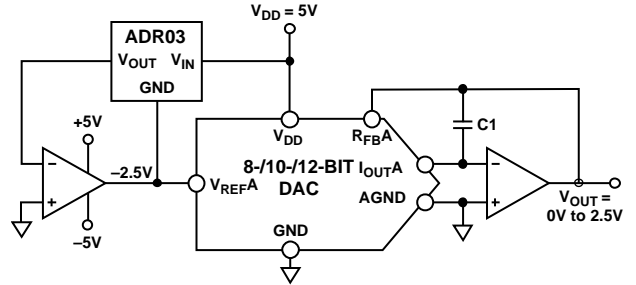

- NOTES**
 1. ADDITIONAL PINS OMITTED FOR CLARITY.
 2. C1 PHASE COMPENSATION (1pF TO 2pF) MAY BE REQUIRED IF A1 IS A HIGH SPEED AMPLIFIER.

Figure 41. Positive Voltage Output with Minimum Components

ADDING GAIN

In applications where the output voltage must be greater than V_{IN} , gain can be added with an additional external amplifier, or it can be achieved in a single stage. Consider the effect of temperature coefficients of the thin film resistors of the DAC. Simply placing a resistor in series with the R_{FB} resistor causes mismatches in the temperature coefficients, resulting in larger gain temperature coefficient errors. Instead, the circuit in Figure 42 shows the recommended method for increasing the gain of the circuit. R1, R2, and R3 should have similar temperature coefficients, but they need not match the temperature coefficients of the DAC. This approach is recommended in circuits where gains of greater than 1 are required.

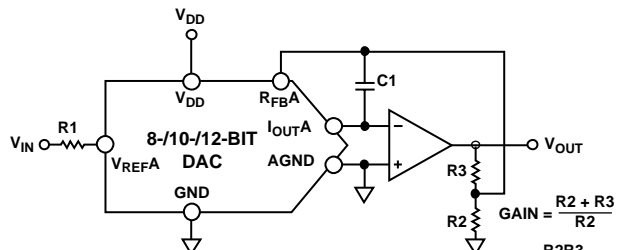

- NOTES**
 1. ADDITIONAL PINS OMITTED FOR CLARITY.
 2. C1 PHASE COMPENSATION (1pF TO 2pF) MAY BE REQUIRED IF A1 IS A HIGH SPEED AMPLIFIER.

Figure 42. Increasing Gain of Current Output DAC

DIVIDER OR PROGRAMMABLE GAIN ELEMENT

Current-steering DACs are very flexible and lend themselves to many applications. If this type of DAC is connected as the feedback element of an op amp and R_{FBA} is used as the input resistor, as shown in Figure 43, the output voltage is inversely proportional to the digital input fraction, D .

For $D = 1 - 2^{-n}$, the output voltage is

$$V_{OUT} = -V_{IN} / D = -V_{IN} / (1 - 2^{-n})$$

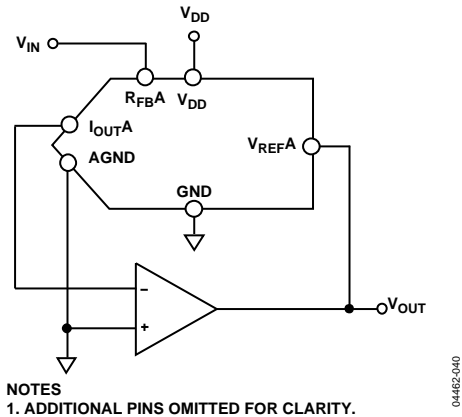

Figure 43. Current-Steering DAC Used as a Divider or Programmable Gain Element

As D is reduced, the output voltage increases. For small values of the digital fraction D , it is important to ensure that the amplifier does not saturate and that the required accuracy is met. For example, an 8-bit DAC driven with the binary code $0x10$ (0001 0000)—that is, 16 decimal—in the circuit of Figure 43 should cause the output voltage to be 16 times V_{IN} . However, if the DAC has a linearity specification of ± 0.5 LSB, D can have a weight in the range of $15.5/256$ to $16.5/256$ so that the possible output voltage is in the range of $15.5 V_{IN}$ to $16.5 V_{IN}$ —an error of 3%, even though the DAC itself has a maximum error of 0.2%.

DAC leakage current is also a potential error source in divider circuits. The leakage current must be counterbalanced by an opposite current supplied from the op amp through the DAC. Because only a fraction, D , of the current into the V_{REF} terminal is routed to the I_{OUT1} terminal, the output voltage changes as follows:

$$\text{Output Error Voltage Due to DAC Leakage} = (\text{Leakage} \times R) / D$$

where R is the DAC resistance at the V_{REF} terminal.

For a DAC leakage current of 10 nA, $R = 10$ k Ω , and a gain (that is, $1/D$) of 16, the error voltage is 1.6 mV.

REFERENCE SELECTION

When selecting a reference for use with the AD54xx series of current output DACs, pay attention to the reference's output voltage temperature coefficient specification. This parameter not only affects the full-scale error, but can also affect the linearity (INL and DNL) performance. The reference temperature coefficient should be consistent with the system accuracy specifications. For example, an 8-bit system required to hold its overall specification to within 1 LSB over the temperature range 0° to 50°C dictates that the maximum system drift with temperature should be less than 78 ppm/ $^\circ\text{C}$. A 12-bit system with the same temperature range to overall specification within 2 LSBs requires a maximum drift of 10 ppm/ $^\circ\text{C}$. Choosing a precision reference with low output temperature coefficient minimizes this error source. Table 9 lists some references available from Analog Devices that are suitable for use with these current output DACs.

AMPLIFIER SELECTION

The primary requirement for the current-steering mode is an amplifier with low input bias currents and low input offset voltage. Because of the code-dependent output resistance of the DAC, the input offset voltage of an op amp is multiplied by the variable gain of the circuit. A change in the noise gain between two adjacent digital fractions produces a step change in the output voltage due to the amplifier's input offset voltage. This output voltage change is superimposed on the desired change in output between the two codes and gives rise to a differential linearity error, which, if large enough, could cause the DAC to be nonmonotonic. The input offset voltage should be $< 1/4$ LSB to ensure monotonic behavior when stepping through codes.

The input bias current of an op amp also generates an offset at the voltage output as a result of the bias current flowing in the feedback resistor, R_{FB} . Most op amps have input bias currents low enough to prevent significant errors in 12-bit applications.

Common-mode rejection of the op amp is important in voltage-switching circuits, because it produces a code-dependent error at the voltage output of the circuit. Most op amps have adequate common-mode rejection for use at 8-, 10-, and 12-bit resolution.

Provided that the DAC switches are driven from true wideband, low impedance sources (V_{IN} and AGND), they settle quickly. Consequently, the slew rate and settling time of a voltage-switching DAC circuit is determined largely by the output op amp. To obtain minimum settling time in this configuration, minimize capacitance at the V_{REF} node (the voltage output node in this application) of the DAC by using low input capacitance buffer amplifiers and careful board design.

Most single-supply circuits include ground as part of the analog signal range, which in turns requires an amplifier that can handle rail-to-rail signals. Analog Devices offers a wide variety of single-supply amplifiers (see Table 10 and Table 11).

Table 9. Suitable ADI Precision References

Part No.	Output Voltage (V)	Initial Tolerance (%)	Temp Drift (ppm/°C)	I _{SS} (mA)	Output Noise (μV p-p)	Package
ADR01	10	0.05	3	1	20	SOIC-8
ADR01	10	0.05	9	1	20	TSOT-23, SC70
ADR02	5	0.06	3	1	10	SOIC-8
ADR02	5	0.06	9	1	10	TSOT-23, SC70
ADR03	2.5	0.10	3	1	6	SOIC-8
ADR03	2.5	0.10	9	1	6	TSOT-23, SC70
ADR06	3	0.10	3	1	10	SOIC-8
ADR06	3	0.10	9	1	10	TSOT-23, SC70
ADR431	2.5	0.04	3	0.8	3.5	SOIC-8
ADR435	5	0.04	3	0.8	8	SOIC-8
ADR391	2.5	0.16	9	0.12	5	TSOT-23
ADR395	5	0.10	9	0.12	8	TSOT-23

Table 10. Suitable ADI Precision Op Amps

Part No.	Supply Voltage (V)	V _{OS} (Max) (μV)	I _B (Max) (nA)	0.1 Hz to 10 Hz Noise (μV p-p)	Supply Current (μA)	Package
OP97	±2 to ±20	25	0.1	0.5	600	SOIC-8
OP1177	±2.5 to ±15	60	2	0.4	500	MSOP, SOIC-8
AD8551	2.7 to 5	5	0.05	1	975	MSOP, SOIC-8
AD8603	1.8 to 6	50	0.001	2.3	50	TSOT
AD8628	2.7 to 6	5	0.1	0.5	850	TSOT, SOIC-8

Table 11. Suitable ADI High Speed Op Amps

Part No.	Supply Voltage (V)	BW @ ACL (MHz)	Slew Rate (V/μs)	VOS (Max) (μV)	I _B (Max) (nA)	Package
AD8065	5 to 24	145	180	1,500	6,000	SOIC-8, SOT-23, MSOP
AD8021	±2.5 to ±12	490	120	1,000	10,500	SOIC-8, MSOP
AD8038	3 to 12	350	425	3,000	750	SOIC-8, SC70-5
AD9631	±3 to ±6	320	1,300	10,000	7,000	SOIC-8

AD5428/AD5440/AD5447

PARALLEL INTERFACE

Data is loaded into the AD5428/AD5440/AD5447 in 8-, 10-, or 12-bit parallel word format. Control lines \overline{CS} and R/\overline{W} allow data to be written to or read from the DAC register. A write event takes place when \overline{CS} and R/\overline{W} are brought low, data available on the data lines fills the shift register, and the rising edge of \overline{CS} latches the data and transfers the latched data-word to the DAC register. The DAC latches are not transparent; therefore, a write sequence must consist of a falling and rising edge on \overline{CS} to ensure that data is loaded into the DAC register and its analog equivalent is reflected on the DAC output.

A read event takes place when R/\overline{W} is held high and \overline{CS} is brought low. Data is loaded from the DAC register, goes back into the input register, and is output onto the data line, where it can be read back to the controller for verification or diagnostic purposes. The input and DAC registers of these devices are not transparent; therefore, a falling and rising edge of \overline{CS} is required to load each data-word.

MICROPROCESSOR INTERFACING

ADSP-21xx-to-AD5428/AD5440/AD5447 Interface

Figure 44 shows the AD5428/AD5440/AD5447 interfaced to the ADSP-21xx series of DSPs as a memory-mapped device. A single wait state may be necessary to interface the AD5428/AD5440/AD5447 to the ADSP-21xx, depending on the clock speed of the DSP. The wait state can be programmed via the data memory wait state control register of the ADSP-21xx (see the ADSP-21xx family's user manual for details).

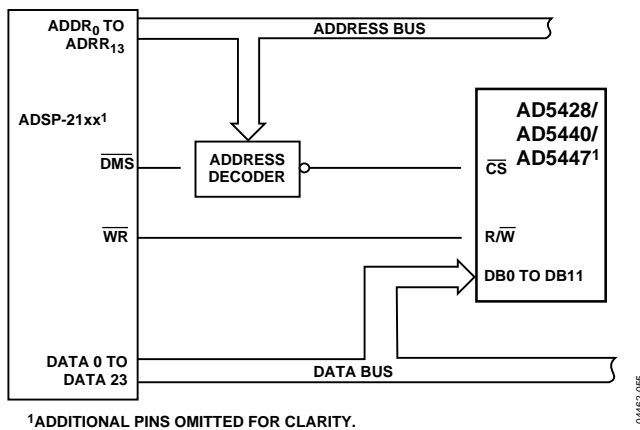

Figure 44. ADSP21xx-to-AD5428/AD5440/AD5447 Interface

8xC51-to-AD5428/AD5440/AD5447 Interface

Figure 45 shows the interface between the AD5428/AD5440/AD5447 and the 8xC51 family of DSPs. To facilitate external data memory access, the address latch enable (ALE) mode is enabled. The low byte of the address is latched with this output pulse during access to the external memory. AD0 to AD7 are the multiplexed low order addresses and data bus, and they require strong internal pull-ups when emitting 1s. During access to external memory, A8 to A15 are the high order address bytes. Because these ports are open drained, they also require strong internal pull-ups when emitting 1s.

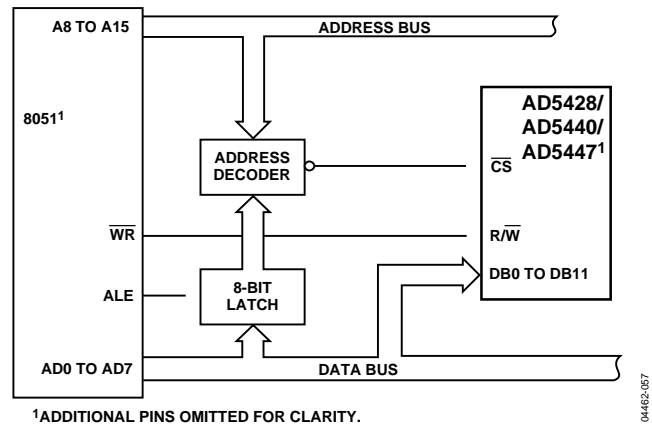

Figure 45. 8xC51-to-AD5428/AD5440/AD5447 Interface

ADSP-BF5xx-to-AD5428/AD5440/AD5447 Interface

Figure 46 shows a typical interface between the AD5428/AD5440/AD5447 and the ADSP-BF5xx family of DSPs. The asynchronous memory write cycle of the processor drives the digital inputs of the DAC. The AMSx line is actually four memory select lines. Internal ADDR lines are decoded into \overline{AMS}_{3-0} , and then these lines are inserted as chip selects. The rest of the interface is a standard handshaking operation.

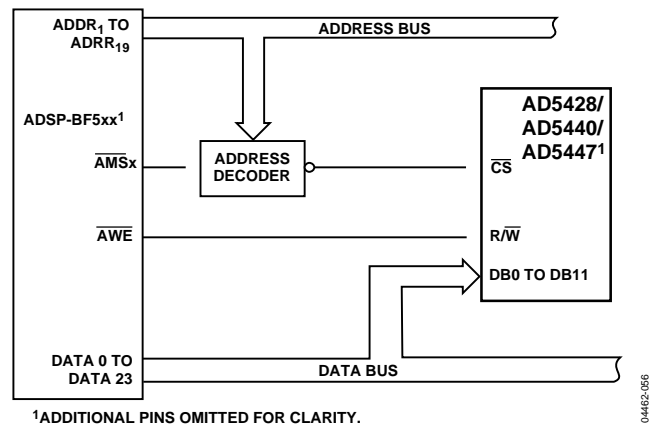

Figure 46. ADSP-BF5xx-to-AD5428/AD5440/AD5447 Interface

PCB LAYOUT AND POWER SUPPLY DECOUPLING

In any circuit where accuracy is important, careful consideration of the power supply and ground return layout helps to ensure the rated performance. The printed circuit board on which the AD5428/AD5440/AD5447 is mounted should be designed so that the analog and digital sections are separate and confined to certain areas of the board. If the DAC is in a system where multiple devices require an AGND-to-DGND connection, the connection should be made at one point only. The star ground point should be established as close as possible to the device.

These DACs should have ample supply bypassing of 10 μF in parallel with 0.1 μF on the supply located as close as possible to the package, ideally right up against the device. The 0.1 μF capacitor should have low effective series resistance (ESR) and low effective series inductance (ESI), like the common ceramic types of capacitors that provide a low impedance path to ground at high frequencies, to handle transient currents due to internal logic switching. Low ESR 1 μF to 10 μF tantalum or electrolytic capacitors should also be applied at the supplies to minimize transient disturbance and filter out low frequency ripple.

Components, such as clocks, that produce fast-switching signals should be shielded with digital ground to avoid radiating noise to other parts of the board, and they should never be run near the reference inputs.

Avoid crossover of digital and analog signals. Traces on opposite sides of the board should run at right angles to each other. This reduces the effects of feedthrough on the board. A

microstrip technique is by far the best method, but its use is not always possible with a double-sided board. In this technique, the component side of the board is dedicated to the ground plane, and signal traces are placed on the soldered side.

It is good practice to use compact, minimum lead length PCB layout design. Leads to the input should be as short as possible to minimize IR drops and stray inductance.

The PCB metal traces between V_{REF} and R_{FB} should also be matched to minimize gain error. To maximize high frequency performance, the I-to-V amplifier should be located as close as possible to the device.

EVALUATION BOARD FOR THE AD5447

The evaluation board consists of an AD5447 DAC and a current-to-voltage amplifier, the AD8065. Included on the evaluation board is a 10 V reference, the ADR01. An external reference may also be applied via an SMB input.

The evaluation kit consists of a CD-ROM with self-installing PC software to control the DAC. The software simply allows the user to write a code to the device.

POWER SUPPLIES FOR THE EVALUATION BOARD

The board requires $\pm 12\text{ V}$ and $+5\text{ V}$ supplies. The $+12\text{ V } V_{\text{DD}}$ and $-12\text{ V } V_{\text{SS}}$ are used to power the output amplifier; the $+5\text{ V}$ is used to power the DAC (V_{DD1}) and transceivers (V_{CC}).

Both supplies are decoupled to their respective ground plane with 10 μF tantalum and 0.1 μF ceramic capacitors.

AD5428/AD5440/AD5447

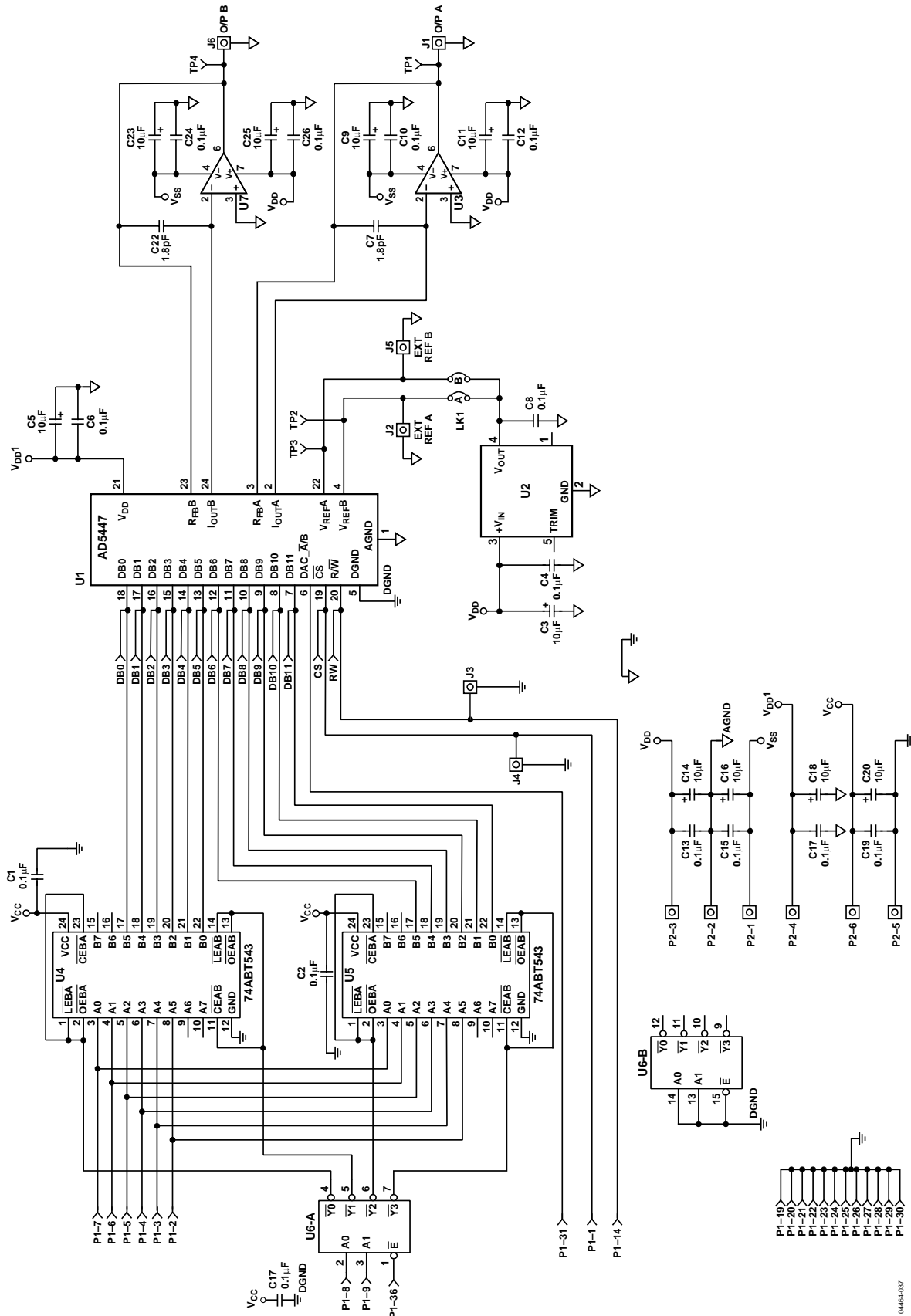
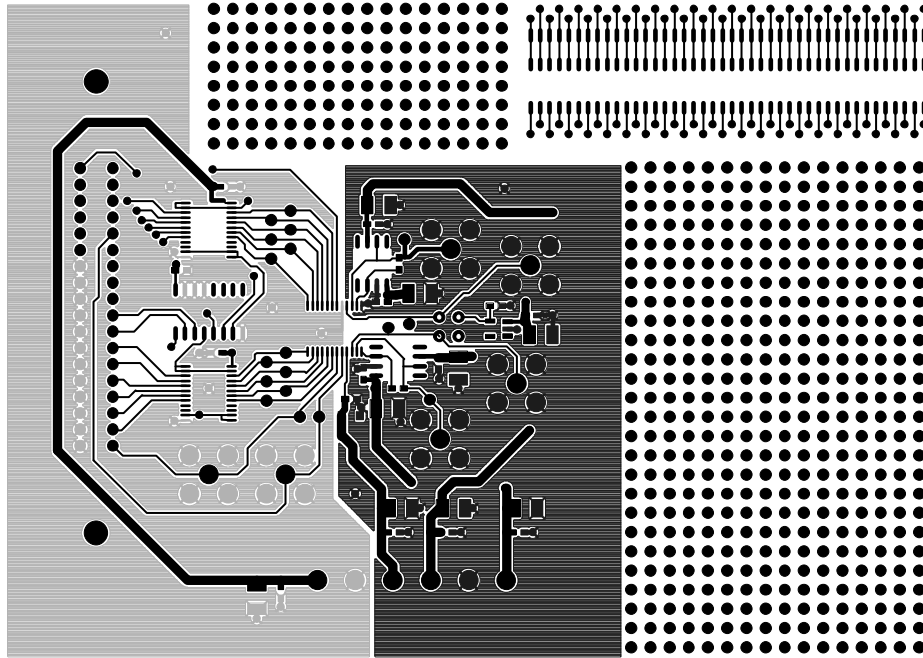
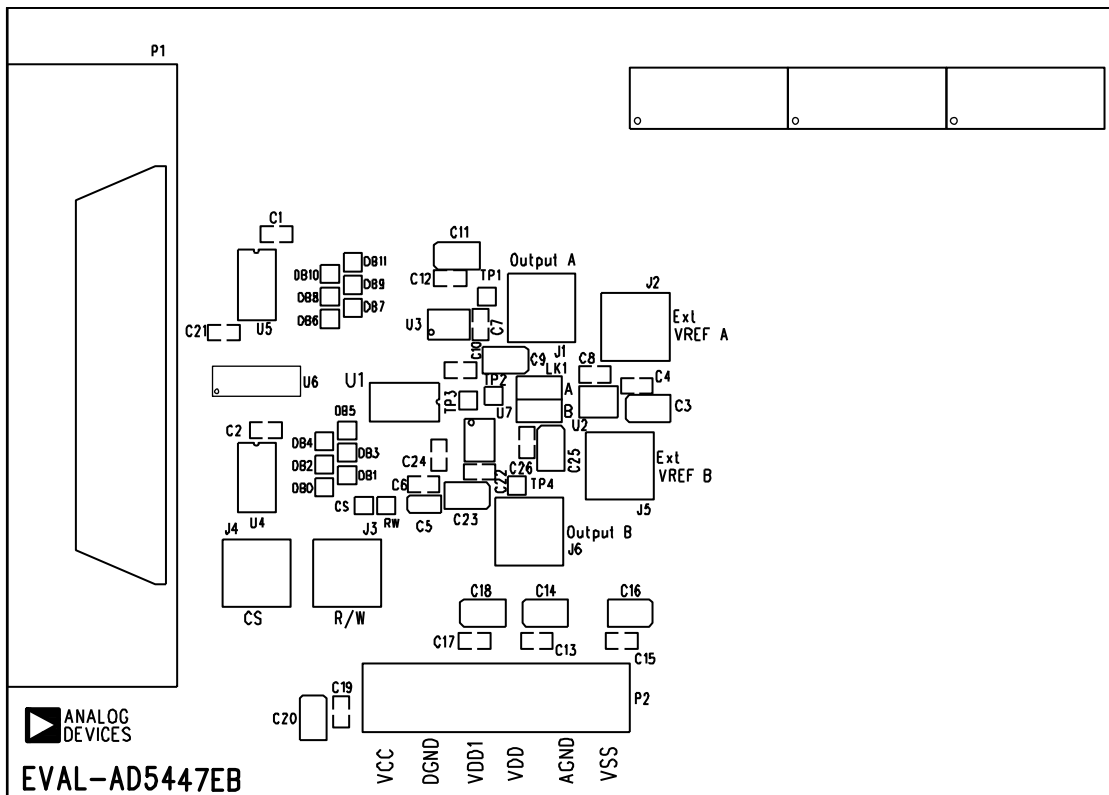

Figure 47. Schematic of AD5447 Evaluation Board



04462-036

Figure 48. Component-Side Artwork



04462-038

Figure 49. Silkscreen—Component-Side View (Top Layer)

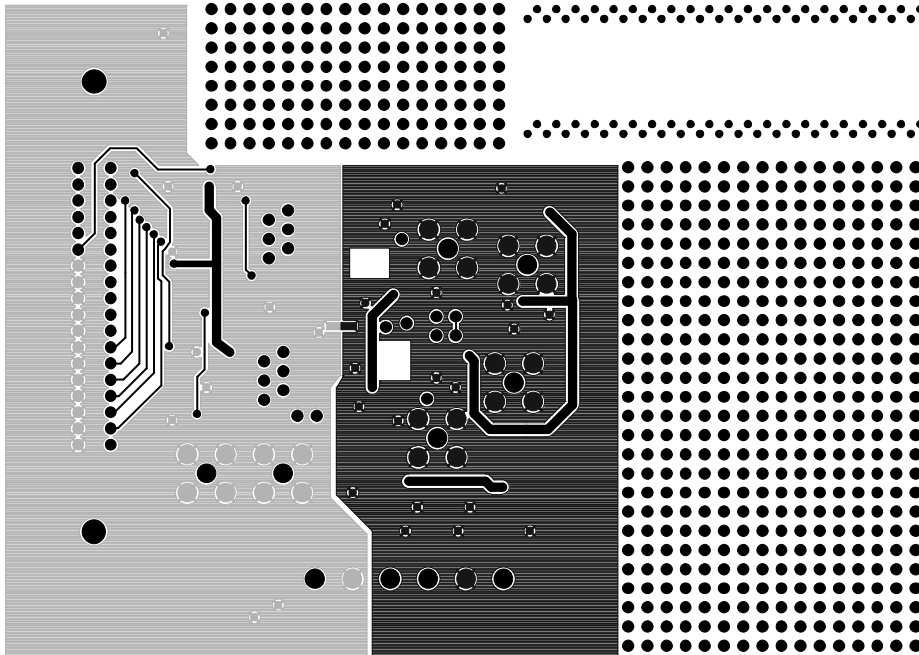

04482-039

Figure 50. Solder-Side Artwork

BILL OF MATERIALS

Table 12.

Name/Position	Part Description	Value	Tolerance (%)	Stock Code
C1	X7R ceramic capacitor	0.1 μ F	10	FEC 499-675
C2	X7R ceramic capacitor	0.1 μ F	10	FEC 499-675
C3	Tantalum capacitor—Taj series	10 μ F 20 V	10	FEC 197-427
C4	X7R ceramic capacitor	0.1 μ F	10	FEC 499-675
C5	Tantalum capacitor—Taj series	10 μ F 10 V	10	FEC 197-130
C6	X7R ceramic capacitor	0.1 μ F	10	FEC 499-675
C7	NPO ceramic capacitor	1.8 pF	10	FEC 721-876
C8	X7R ceramic capacitor	0.1 μ F	10	FEC 499-675
C9	Tantalum capacitor—Taj series	10 μ F 20 V	10	FEC 197-427
C10	X7R ceramic capacitor	0.1 μ F	10	FEC 499-675
C11	Tantalum capacitor—Taj series	10 μ F 20 V	10	FEC 197-427
C12	X7R ceramic capacitor	0.1 μ F	10	FEC 499-675
C13	X7R ceramic capacitor	0.1 μ F	10	FEC 499-675
C14	Tantalum capacitor—Taj series	10 μ F 20 V	10	FEC 197-427
C15	X7R ceramic capacitor	0.1 μ F	10	FEC 499-675
C16	Tantalum capacitor—Taj series	10 μ F 20 V	10	FEC 197-427
C17	X7R ceramic capacitor	0.1 μ F	10	FEC 499-675
C18	Tantalum capacitor—Taj series	10 μ F 20 V	10	FEC 197-427
C19	X7R ceramic capacitor	0.1 μ F	10	FEC 499-675
C20	Tantalum capacitor—Taj series	10 μ F 20 V	10	FEC 197-427
C21	X7R ceramic capacitor	0.1 μ F	10	FEC 499-675
C22	NPO ceramic capacitor	1.8 pF	10	FEC 721-876
C23	Tantalum capacitor—Taj series	10 μ F 20 V	10	FEC 197-427
C24	X7R ceramic capacitor	0.1 μ F	10	FEC 499-675
C25	Tantalum capacitor—Taj series	10 μ F 20 V	10	FEC 197-427
C26	X7R ceramic capacitor	0.1 μ F	10	FEC 499-675
CS, DB0 to DB11	Red testpoint			FEC 240-345 (Pack)
J1 to J6	SMB socket			FEC 310-682
J2	SMB socket			FEC 310-682
J3	SMB socket			FEC 310-682
J4	SMB socket			FEC 310-682
J5	SMB socket			FEC 310-682
J6	SMB socket			FEC 310-682
LK1	3-pin header (2 \times 2)			FEC 511-791 and FEC 528-456
P1	36-pin Centronics connector			FEC 147-753
P2	6-pin terminal block			FEC 151-792
RW	Red testpoint			FEC 240-345 (Pack)
TP1 to TP4	Red testpoint			FEC 240-345 (Pack)
U1	AD5447			AD5447YRU
U2	ADR01			ADR01AR
U3	AD8065			AD8065AR
U4, U5	74ABT543			Fairchild 74ABT543CMTC
U6	74139			CD74HCT139M
U7	AD8065			AD8065AR
Each Corner	Rubber stick-on feet			FEC 148-922

AD5428/AD5440/AD5447

OVERVIEW OF AD54XX DEVICES

Table 13.

Part No.	Resolution	No. DACs	INL (LSB)	Interface	Package ¹	Features
AD5424	8	1	±0.25	Parallel	RU-16, CP-20	10 MHz BW, 17 ns \overline{CS} pulse width
AD5426	8	1	±0.25	Serial	RM-10	10 MHz BW, 50 MHz serial
AD5428	8	2	±0.25	Parallel	RU-20	10 MHz BW, 17 ns \overline{CS} pulse width
AD5429	8	2	±0.25	Serial	RU-10	10 MHz BW, 50 MHz serial
AD5450	8	1	±0.25	Serial	UJ-8	10 MHz BW, 50 MHz serial
AD5432	10	1	±0.5	Serial	RM-10	10 MHz BW, 50 MHz serial
AD5433	10	1	±0.5	Parallel	RU-20, CP-20	10 MHz BW, 17 ns \overline{CS} pulse width
AD5439	10	2	±0.5	Serial	RU-16	10 MHz BW, 50 MHz serial
AD5440	10	2	±0.5	Parallel	RU-24	10 MHz BW, 17 ns \overline{CS} pulse width
AD5451	10	1	±0.25	Serial	UJ-8	10 MHz BW, 50 MHz serial
AD5443	12	1	±1	Serial	RM-10	10 MHz BW, 50 MHz serial
AD5444	12	1	±0.5	Serial	RM-8	10 MHz BW, 50 MHz serial
AD5415	12	2	±1	Serial	RU-24	10 MHz BW, 50 MHz serial
AD5405	12	2	±1	Parallel	CP-40	10 MHz BW, 17 ns \overline{CS} pulse width
AD5445	12	2	±1	Parallel	RU-20, CP-20	10 MHz BW, 17 ns \overline{CS} pulse width
AD5447	12	2	±1	Parallel	RU-24	10 MHz BW, 17 ns \overline{CS} pulse width
AD5449	12	2	±1	Serial	RU-16	10 MHz BW, 50 MHz serial
AD5452	12	1	±0.5	Serial	UJ-8, RM-8	10 MHz BW, 50 MHz serial
AD5446	14	1	±1	Serial	RM-8	10 MHz BW, 50 MHz serial
AD5453	14	1	±2	Serial	UJ-8, RM-8	10 MHz BW, 50 MHz serial
AD5553	14	1	±1	Serial	RM-8	4 MHz BW, 50 MHz serial clock
AD5556	14	1	±1	Parallel	RU-28	4 MHz BW, 20 ns \overline{WR} pulse width
AD5555	14	2	±1	Serial	RM-8	4 MHz BW, 50 MHz serial clock
AD5557	14	2	±1	Parallel	RU-38	4 MHz BW, 20 ns \overline{WR} pulse width
AD5543	16	1	±2	Serial	RM-8	4 MHz BW, 50 MHz serial clock
AD5546	16	1	±2	Parallel	RU-28	4 MHz BW, 20 ns \overline{WR} pulse width
AD5545	16	2	±2	Serial	RU-16	4 MHz BW, 50 MHz serial clock
AD5547	16	2	±2	Parallel	RU-38	4 MHz BW, 20 ns \overline{WR} pulse width

¹ RU = TSSOP, CP = LFCSP, RM = MSOP, UJ = TSOT.

OUTLINE DIMENSIONS

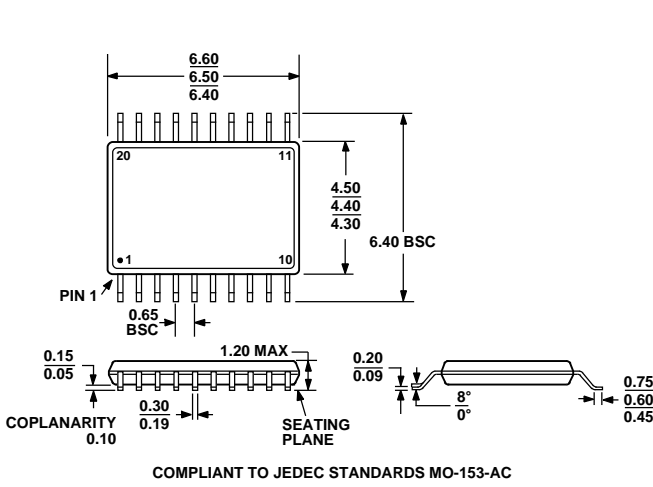

Figure 51. 20-Lead Thin Shrink Outline Package [TSSOP] (RU-20)
Dimensions shown in millimeters

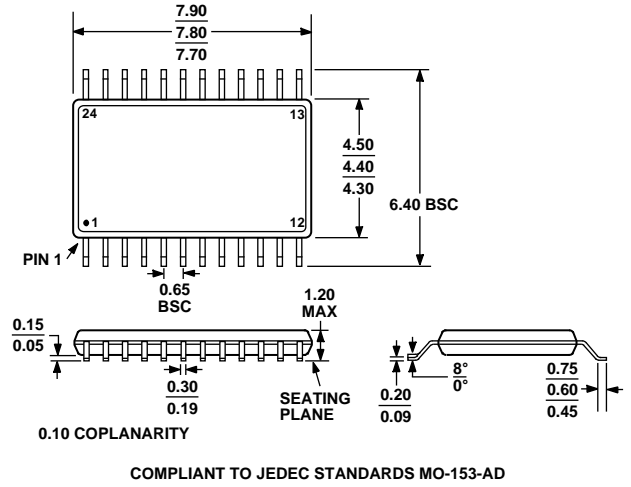

Figure 52. 24-Lead Thin Shrink Small Outline Package [TSSOP] (RU-24)
Dimensions shown in millimeters

ORDERING GUIDE

Model ¹	Resolution	INL (LSB)	Temperature Range	Package Description	Package Option
AD5428YRU	8	±0.5	-40 °C to +125°C	20-Lead TSSOP	RU-20
AD5428YRU-REEL	8	±0.5	-40 °C to +125°C	20-Lead TSSOP	RU-20
AD5428YRU-REEL7	8	±0.5	-40 °C to +125°C	20-Lead TSSOP	RU-20
AD5428YRUZ	8	±0.5	-40 °C to +125°C	20-Lead TSSOP	RU-20
AD5428YRUZ-REEL	8	±0.5	-40 °C to +125°C	20-Lead TSSOP	RU-20
AD5428YRUZ-REEL7	8	±0.5	-40 °C to +125°C	20-Lead TSSOP	RU-20
AD5440YRU	10	±0.5	-40 °C to +125°C	24-Lead TSSOP	RU-24
AD5440YRU-REEL	10	±0.5	-40 °C to +125°C	24-Lead TSSOP	RU-24
AD5440YRU-REEL7	10	±0.5	-40 °C to +125°C	24-Lead TSSOP	RU-24
AD5440YRUZ	10	±0.5	-40 °C to +125°C	24-Lead TSSOP	RU-24
AD5440YRUZ-REEL	12	±1	-40 °C to +125°C	24-Lead TSSOP	RU-24
AD5440YRUZ-REEL7	12	±1	-40 °C to +125°C	24-Lead TSSOP	RU-24
AD5447YRU	12	±1	-40 °C to +125°C	24-Lead TSSOP	RU-24
AD5447YRU-REEL	12	±1	-40 °C to +125°C	24-Lead TSSOP	RU-24
AD5447YRUZ	12	±1	-40 °C to +125°C	24-Lead TSSOP	RU-24
AD5447YRUZ-REEL	12	±1	-40 °C to +125°C	24-Lead TSSOP	RU-24
AD5447YRUZ-REEL7	12	±1	-40 °C to +125°C	24-Lead TSSOP	RU-24
EVAL-AD5447EBZ				Evaluation Kit	

¹ Z = RoHS Compliant Part.

AD5428/AD5440/AD5447

NOTES

NOTES

AD5428/AD5440/AD5447

NOTES