

FEATURES AND SPECIFICATIONS

Features and Benefits

- Cavities for coaxial and high power inserts
- Dual opposing beam contact
- Preloaded solder power contacts available
- Flux-proof option
- Solder tails for 1.6mm (.062") and 3.2mm (.125") PCBs

Reference Information

Product Specification: PS-85042-0001
 Packaging: Tray
 UL File No.: E29179
 CSA File No.: LR19980-390
 Mates With:

85009—Right angle male style M

85017—Straight male style M "inverse"

Use With: **85022**—Coaxial and high current inserts

Electrical

Current: 1.5A
 Contact Resistance: 20mΩ max.

Mechanical

Mating Force: 0.93N max.

Physical

Housing: Glass-filled polyester, UL 94V-0
 Contact: Copper Alloy
 Operating Temperature: -55 to +125°C



**2.54mm (.100") Pitch
 DIN 41612/IEC 603-2
 Mixed Layout Connector**

85048

**Female
 Style M**

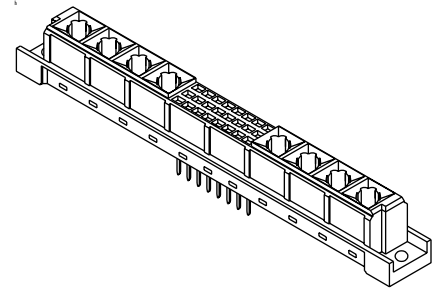

CATALOG DRAWING (FOR REFERENCE ONLY)

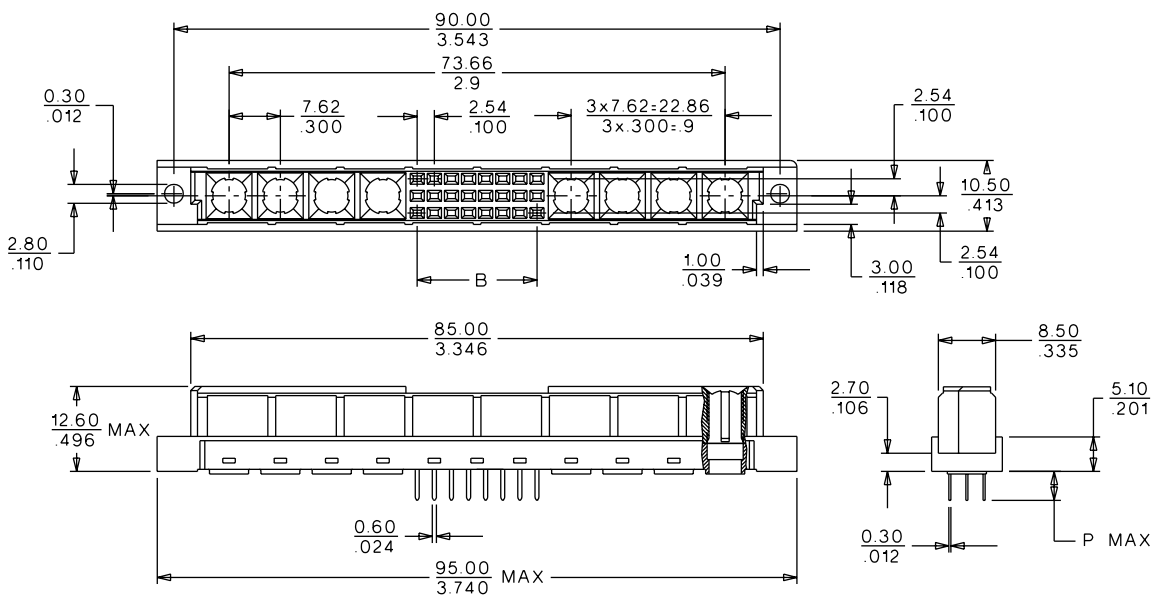

ORDERING INFORMATION AND DIMENSIONS

Circuits	Order No.		Contact Loading	Rows	Solder Tail Dimension P	Option(s)
	Performance Level*					
	1	2				
24+8	85048-1316	85048-0969	Full	a, b, c	2.9 (.114)	
	85048-1275	85048-0024			4.5 (.177)	
42+6	85048-1421	85048-0878	Full	a, b, c	2.9 (.114)	
	85048-0660	85048-0062			4.5 (.177)	Flux-proof
60+4	85048-0555	85048-1122	Full	a, b, c	2.9 (.114)	
	85048-0361	85048-0115			4.5 (.177)	Flux-proof
		85048-0139			2.9 (.114)	
78+2	85048-0567	85048-0866	Full	a, b, c	2.9 (.114)	
	85048-0737	85048-0153			4.5 (.177)	Flux-proof
		85048-0323				Flux-proof

For other versions contact Molex

* Performance levels based on test conditions per DIN 41612, part 5:

1: >500 mating cycles. 10 day industrial environment (S02)

2: >400 mating cycles. 4 day industrial environment (S02)