

NOTES: UNLESS OTHERWISE SPECIFIED

- FOR GENERAL SERIES SPECIFICATIONS, SEE SDPRF-206.
- MATERIAL SPECIFICATIONS:
 BAYONET SLEEVE, BODY, CONTACT, CLAMP: BRASS PER ASTM B16
 INSULATOR: TEFLON PER ASTM D1710
 SPRING WASHER, OUTER CONTACT: BERYLLIUM COPPER, ASTM-B-194
 GASKET: SILICONE RUBBER
- FINISH SPECIFICATIONS:
 BAYONET SLEEVE, BODY, CLAMP: .000100MIN NICKEL PER AMS-QQ-N-290
 OVER COPPER FLASH PER ASTM B734 (ROHS)
 CONTACT: .000030 MIN. GOLD PER ASTM B488, OVER NICKEL PER AMS-QQ-N-290 (ROHS)
 SPRING WASHER: .000200 MIN SILVER PER QQ-S-365 OVER COPPER PER ASTM B734 (ROHS)
 ALL OTHER METAL PARTS: .000050 MIN NICKEL PER AMS-QQ-N290 OVER
 .000050 MIN COPPER PER ASTM B734 (ROHS)
- FOR USE WITH TACHII CABLE TCX-5CFWS OR EQUIVALENT .
- ASSEMBLE TO CABLE USING CAP-702.
- ELECTRIC SPECIFICATIONS:
 IMPEDANCE: 75 OHMS
 FREQUENCY RANGE: DC TO 3 GHz
 RETURN LOSS: 26.5 dB MIN. (DC TO)

REV	DESCRIPTION	BY DATE	APPD
B	REVISED PER ECR-ER22873	CY 03/22/10	CTC

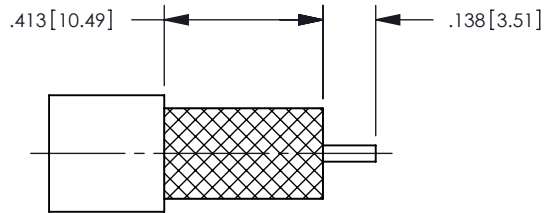
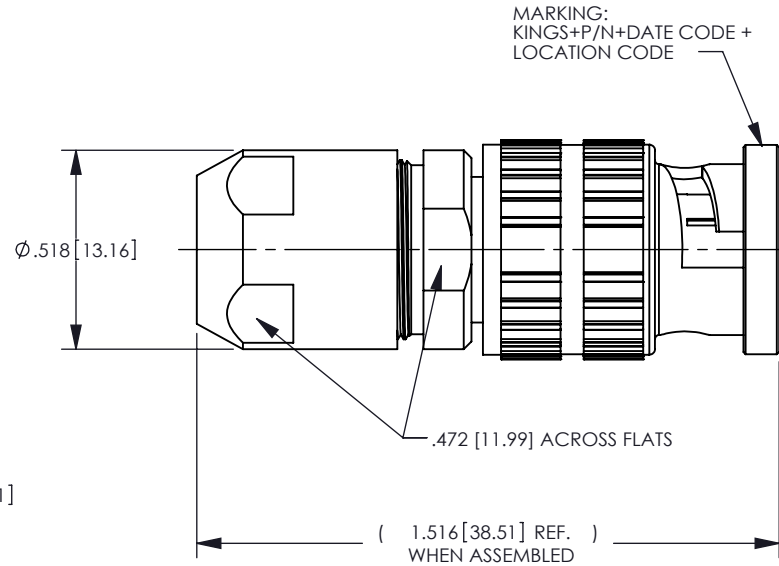

RECOMMENDED CABLE TRIMMING DIMENSIONS

CATALOG P/N: 2065-700-5CW01N

PER ASME Y14.5M-1994 UNLESS OTHERWISE SPECIFIED: DIMENSIONS ARE IN INCHES [MM] TOLERANCES: DECIMAL: .XX [X.X] ± .01 [0.3] .XXX [X.XX] ± .005 [0.13] .XXXX [X.XXX] ± .0005 [0.013] ANGLES: ± 2° SCALE: 2:1				 by WINCHESTER <small>ELECTRONICS</small> Winchester Electronics Corporation 62 Barnes Industrial Road North Wallingford, Connecticut 06492	
CUSTOMER SALES DRAWING			THIRD ANGLE 	BNC 75 PLUG FOR TCX-5CFWS (ROSH COMPLIANT)	
DRAWN	DATE	APPROVED	DATE	A	SD2065-700-5CW01N
CY	12/17/08	D Cam	12/19/08		
APPROVED	DATE	APPROVED	DATE	SHT	OF
WPM	12/19/08	XXX	XX/XX/XX	1	1
				REV	B