



**L3234
L3235N**

HIGHLY INTEGRATED SLIC KIT TARGETED TO PABX AND KEY SYSTEM APPLICATIONS

- HIGHLY INTEGRATED SUBSCRIBER LINE INTERFACE KIT FOR PABX AND KEY SYSTEM APPLICATIONS
- IMPLEMENTS ALL KEY ELEMENTS OF THE BORSCHT FUNCTION
- INTEGRATED ZERO CROSSING BALANCED RINGING INJECTION ELIMINATES EXTERNAL RELAY AND CENTRALISED RINGING GENERATOR
- ZERO NOISE INJECTED ON ADJACENT LINES DURING RINGING SEQUENCE
- LOW POWER IN STANDBY AND ACTIVE MODES
- BATTERY FEED WITH PROGRAMMABLE LIMITING CURRENT
- PARALLEL LATCHED DIGITAL INTERFACE
- SIGNALLING FUNCTIONS (OFF HOOK, GND-KEY)
- LOW NUMBER OF EXTERNAL COMPONENTS
- INTEGRATED THERMAL PROTECTION
- INTEGRATED OVER CURRENT PROTECTION
- 0°C TO 70°C: L3234/L3235N
- -40°C TO 85°C: L3234T/L3235NT

DESCRIPTION

The L3234/L3235N is a highly integrated SLIC KIT targeted to PABX and key system applications

The kit integrates the majority of functions required to interface a telephone line. The L3234/L3235N implements the main features of the broths function:

- Battery Feed (Balanced Mode)
- Ringing Injection
- Signalling Detection
- Hybrid Function

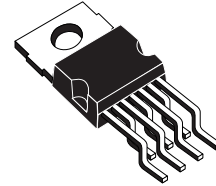

HEPTAWATT

ORDERING NUMBER: L3234

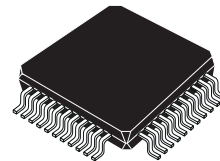

TQFP44

ORDERING NUMBER: L3235N

The Kit comprises 2 devices, the L3234 ringing injector fabricated in Bipolar in 140V Technology.

Its function is to amplify and inject in balanced mode with zero crossing the ringing signal. The device requires an external positive supply of 100V and a low level sinusoid of approx. 950mVrms. The L3235N Line Feeder is integrated in 60V Bipolar Technology. The L3235N provides battery feed to the line with programmable current limitation. The two to four wire voice frequency signal conversion is implemented by the L3235N and line terminating and balance impedances are externally programmable. The L3234/L3235N kit is designed for low power dissipation. In a short loop condition the extra power is dissipated on an external transistor. The Kit is controlled by five wire parallel bus and interfaces easily to all the STLC5046 and STLC5048 CODECs. In Kit with STLC5048 (see fig 1) the line impedance synthesis and echo canceling are performed inside the CODEC.

L3234

Solid State Ringing Injector

DESCRIPTION

The L3234 is a monolithic integrated circuit which is part of a kit of solid state devices for the subscriber line interface. The L3234 sends a ringing signal into a two wires analog telephone line in balanced mode. The AC ringing signal amplitude is up to 60Vrms, and for that purpose a positive supply voltage of +100V shall be available on the subscriber card.

The L3234 receives a low amplitude ringing signal (950mVrms) and provide the voltage/current amplification (60Vrms/70mA) when the enable input is active ($CS \geq 2V$). In disable mode ($CS \leq 0.8V$) the power consumption of the chip is very low (<14mW).

The circuit is designed with a high voltage bipolar technology ($V_{CE0} > 140V / V_{CBO} > 250V$).

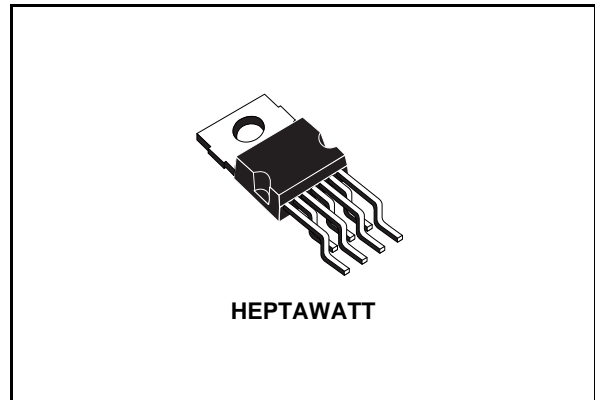

The package is a moulded plastic power package (Heptawatt) suitable also for surface mounting.

BLOCK DIAGRAM

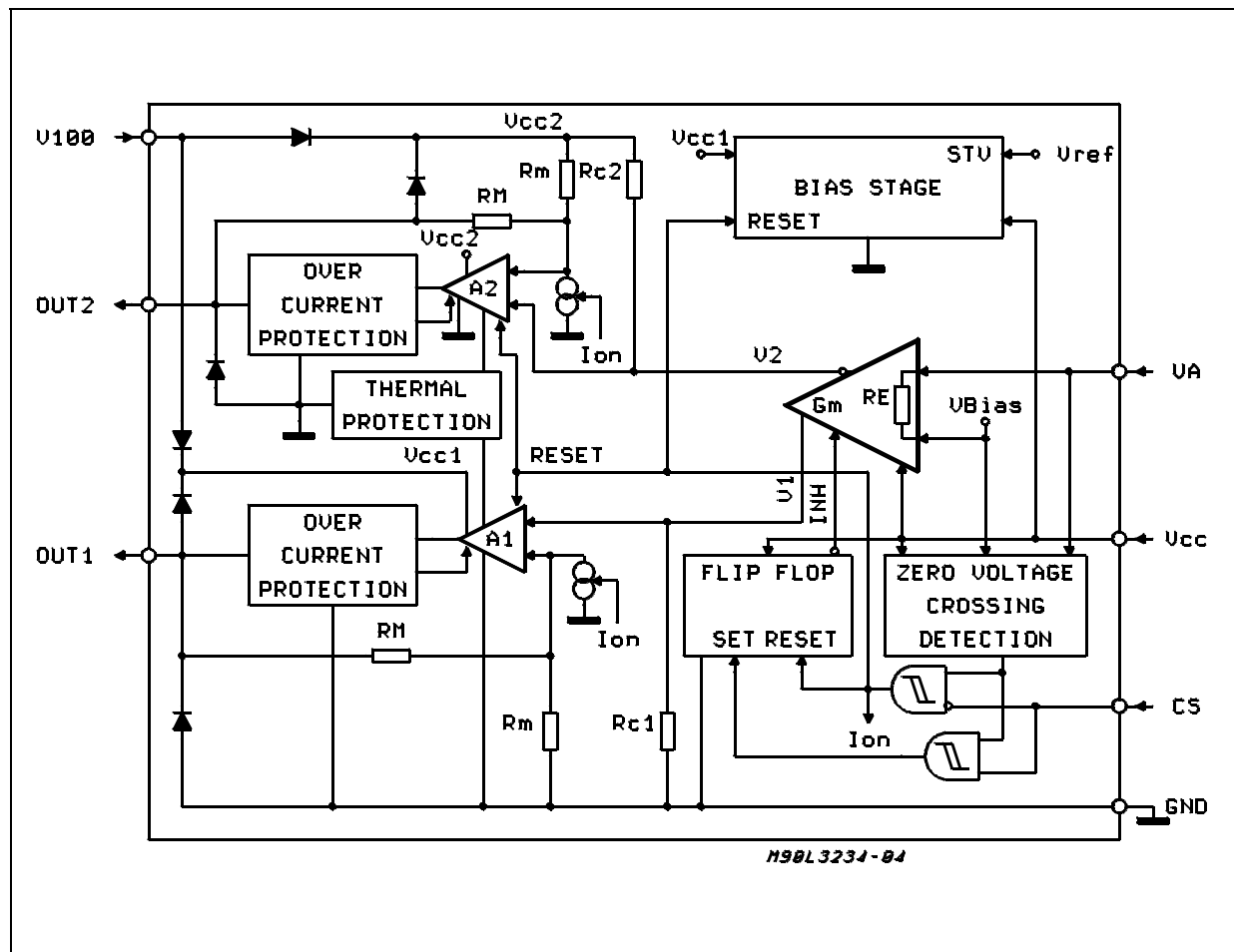

L3234 - L3235N

PIN CONNECTION (Top view)

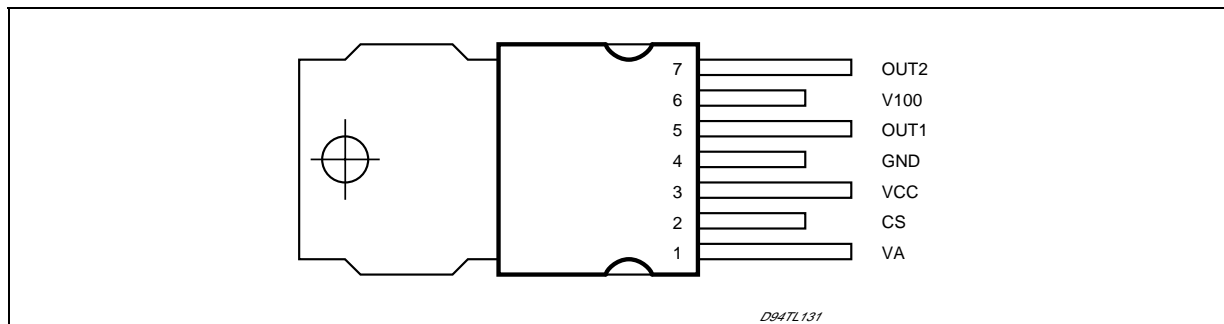

ABSOLUTE MAXIMUM RATINGS

Symbol	Parameter	Value	Unit
V100	Positive Power Supply Voltage	+120	V
V _{CC}	5V Power Supply Voltage	5.5	V
V _A	Low Voltage Ringing Signal (with V100 = 120Vdc)	1.4	V _{rms}
CS	Logical Ring Drive Input	V _{CC}	
T _j	Max. Junction Temperature	150	°C
T _{stg}	Storage Temperature	-55 to +150	°C

OPERATING RANGE

Symbol	Parameter	Value	Unit
V100	High Power Supply Voltage	95 to 105	V
V _{CC}	Low Power Supply Voltage	5 ±5%	V
V _A	Low Voltage Ringing Signal	600 to 950 within 10Hz - 100Hz	V _{rms}
T _{op}	Operating Temperature for L3234	0 to 70	°C
T _{jop}	Max. Junction Operating Temperature (due to thermal protection)	130	°C

Note: Operating ranges define those limits between which the functionality of the device is guaranteed.

THERMAL DATA

Symbol	Description	Value	Unit
R _{th j-case}	Thermal Resistance Junction-case	Max. 4	°C/W
R _{th j-amb}	Thermal Resistance Junction-ambient	Max. 50	°C/W

PIN DESCRIPTION

Pin	Name	Description
1	VA	Low Voltage Ringing Signal Input
2	CS	Logical Ring Drive Input
3	V _{CC}	+5V Low Power Supply
4	GND	Common Analog-Digital Ground
5	OUT1	Ringing Signal Output
6	V100	+100V High Power Supply
7	OUT2	Ringing Signal Output in Opposite Phase with Out1

OPERATION DESCRIPTION

The Fig. 1 show the simplified circuit configuration

of the L3234 Solid State Ringing injector when used with the L3235N Line Feeder.

Figure 1: L3234/L3235N Circuit Configuration

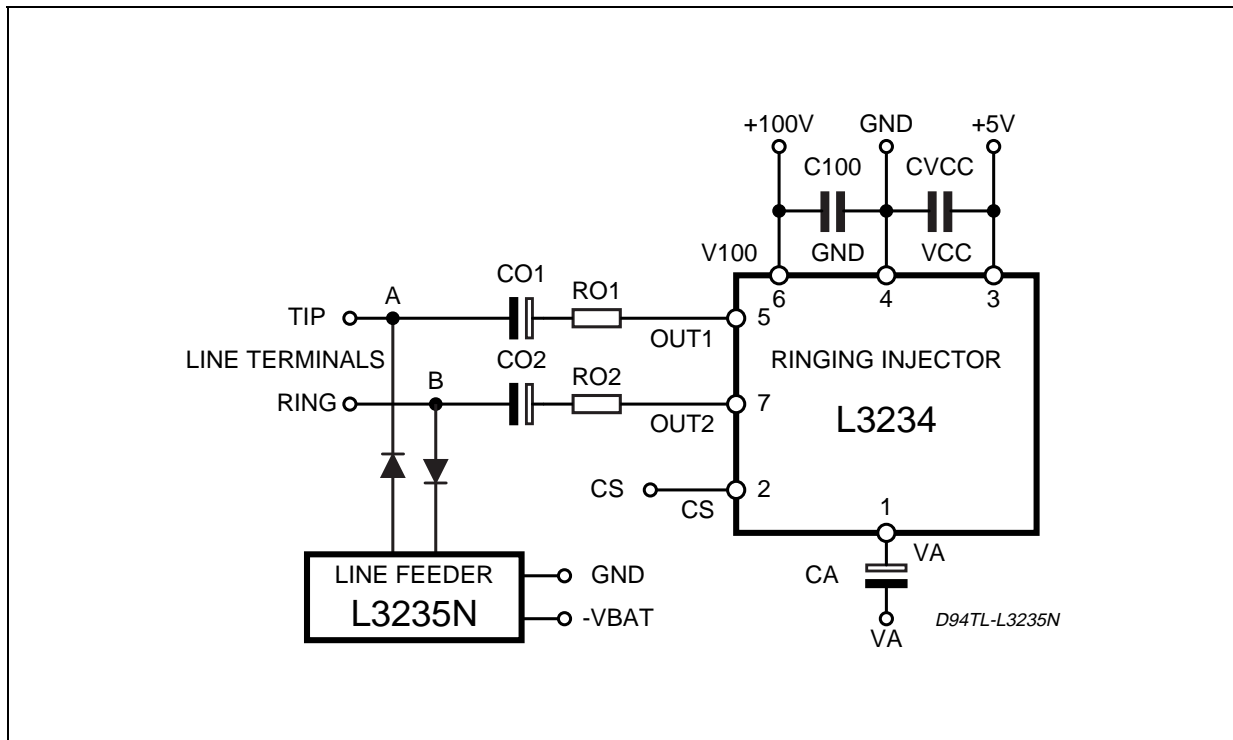

EXTERNAL COMPONENTS LIST

In the following table are shown the recommended external components values for L3234.

Ref.	Value	Involved Parameter or Function
R01, R02	82Ω	Ringling Feeding Series Resistors
C01, C02	10μF - 160V	Ringling Feeding De coupling Capacitors
CA	4.7μF - 10V	Low Level Ringling Signal De coupling Capacitor
C100	100nF - 100V	Positive Battery Filter
CV _{CC}	100nF	+5V Supply Filter

When the ringing function is selected by the subscriber card, a low level signal is continuously applied to pin 1 through a de coupling capacitor. Then the logical ring drive signal CS provided by L3235N is applied to pin 2 with a cadenced mode.

The ringing cycles are synchronised by the L3234 in such a way that the ringing starts and stops always when the analog input signal crosses zero.

When the ringing injection is enabled (CS = "1"), an AC ringing signal is injected in a balanced

mode into the telephone line.

When the ringing injection is disabled (CS = "0"), the output voltage on OUT2 raises to the high power supply, whereas on OUT1, it falls down to ground.

The L3234 has a low output impedance when sending the signal, and high output impedance when the ringing signal is disabled

In fig. 2 the dynamic features of L3234 are shown.

Figure 2: Dynamic Features of L3234

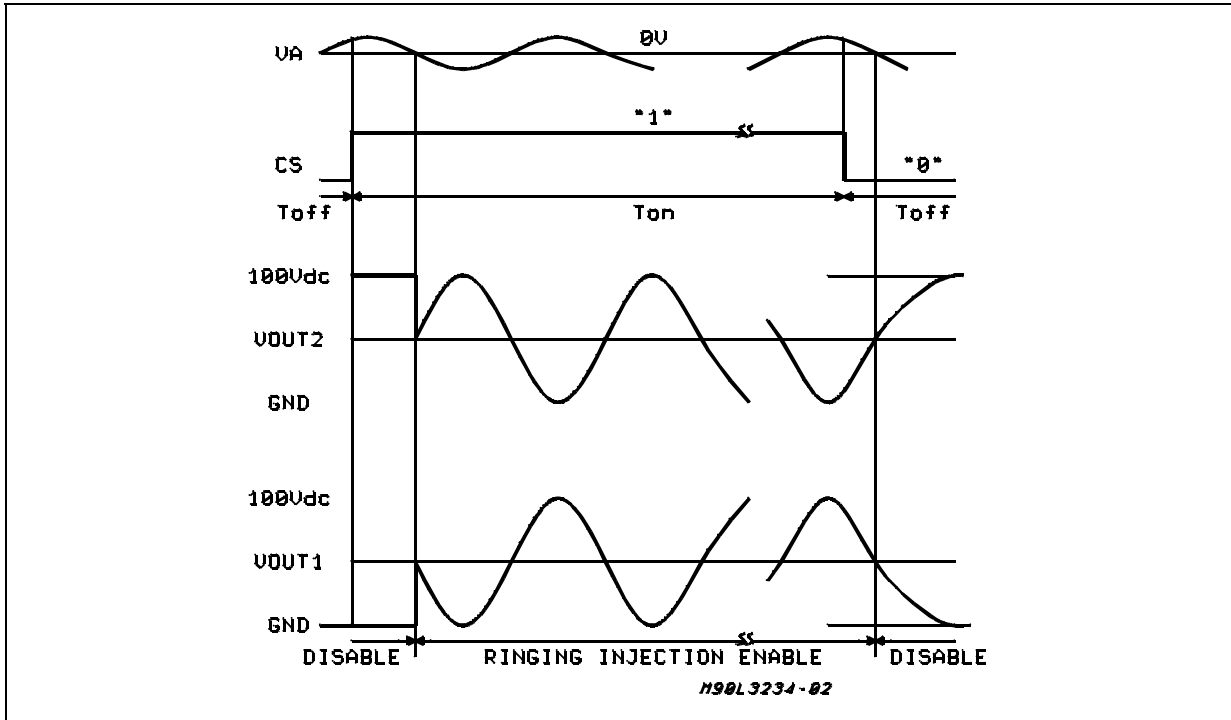

DATA TRANSMISSION INTERFERENCE TEST

The L3234 meet the requirements of the technical specification ST/PAA/TPA/STP/1063 from the CNET. The test circuit used is indicated below.

The measured error rate for data transmission is lower than 10^{-6} during the ringing phase.

This test measures if during the ringing phase the circuit induce any noise to the closer lines.

Figure 3: Test Circuit Data Transmission Interference Test

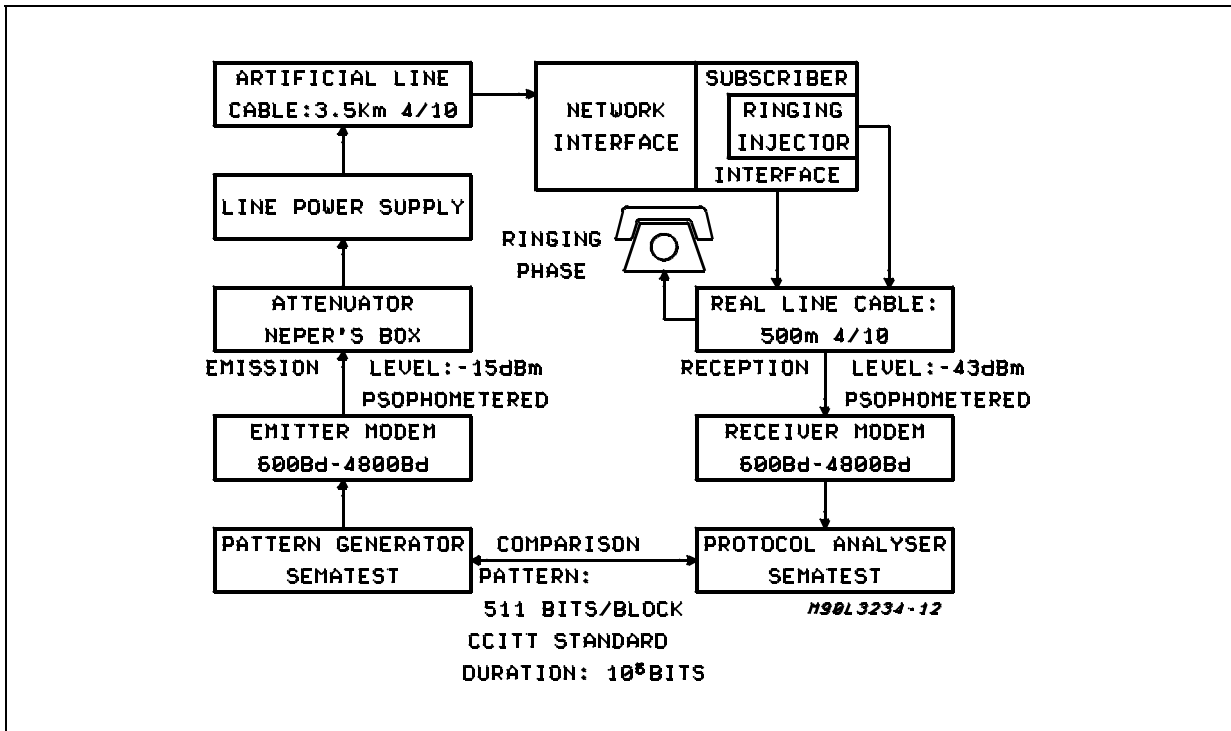

ELECTRICAL CHARACTERISTICS (Test conditions: $V_{100} = +100V$, $V_{CC} = +5V$, $T_{amb} = 25^{\circ}C$, unless otherwise specified)

Note: Testing of all parameter is performed at $25^{\circ}C$. Characterisation, as well as the design rule used allow correlation of tested performance with actual performances at other temperatures. All parameters listed here are met in the range $0^{\circ}C$ to $+70^{\circ}C$.

Symbol	Parameter	Test Condition	Min.	Typ.	Max.	Unit	Fig
STAND BY MODE: CS = "0"							
$I_S (V_{100})$ $I_S (V_{CC})$	Consumption	$V_A = 950mV_{rms}; 50Hz$		45 560	100 800	μA μA	
V_{SOUT1} V_{SOUT2}	DC Output Voltage	$V_A = 950mV_{rms}; 50Hz$	92		6	V V	
Z_{SOUT1} Z_{SOUT2}	Output Impedance		70 70			$k\Omega$ $k\Omega$	4
	Z_{OUT} Matching				15	%	
THD	Harmonic Distortion During Emission	$V_{LINE} \leq 6dBm; f = 1kHz$		-46	-40	dB	5

RINGING PHASE: CS = "1"
DC OPERATION

$I_R (V_{100})$ $I_R (V_{CC})$	Consumption	$Z_{LINE} = \infty$ $V_A = 950mV_{rms}; 50Hz$		2.5 2.2	5 3	mA mA	
V_{ROUT1} V_{ROUT2}	DC Output Voltage	$V_A = 0V$	44 44		56 56	V V	
V_{IH} $I_{IH} (CS = 0)$	Threshold Voltage on the Logical Input CS	$V_A = 950mV_{rms}; 50Hz$	2.0		1	V μA	6
V_{IL} $I_{IL} (CS = 0)$					0.8 1	V μA	
I_{lim}	DC Line Current Limitation	$V_A = 0V$	70		150	mA	12

AC OPERATION

V_{OUT1}/V_A V_{OUT2}/V_A	Ringing Gain	$Z_{LINE} = 2.2\mu F + 1k\Omega$ $V_A = 0dBm$	29.5 29.5	30 30		dB dB	7
$V_{OUT1} - V_{OUT1}$	Ringing Signal	$Z_{LINE} = 2.2\mu F + 1k\Omega$ $V_A = 950mV_{rms}; 50Hz$	57	60		Vrms	7
THD V_{LINE}	Harmonic Distortion	$V_A = 950mV_{rms}; 50Hz$			5	%	
$Z_{IN} (VA)$	Input Impedance	$V_A = 950mV_{rms}; 50Hz$	40			$k\Omega$	8
Z_{OUT}	Differential Output Impedance	$I_{LINE} < 50mArms$			20	Ω	9

TEST CIRCUITS

Figure 4.

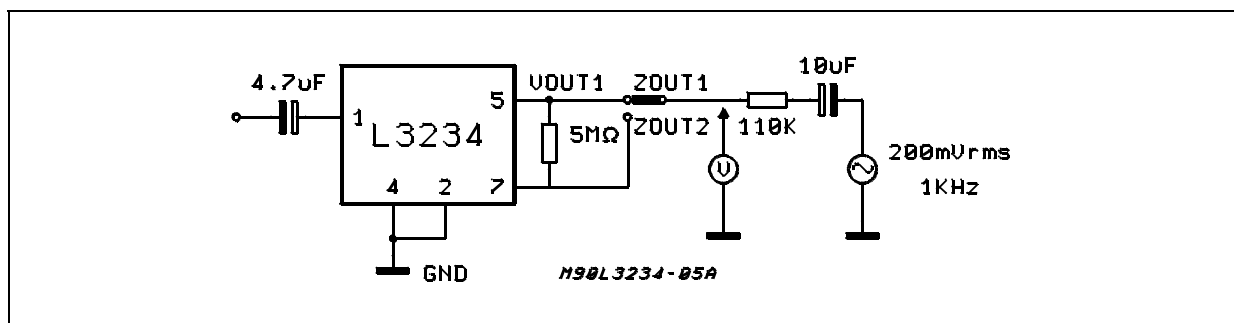

L3234 - L3235N

TEST CIRCUITS (continued)
Figure 5.

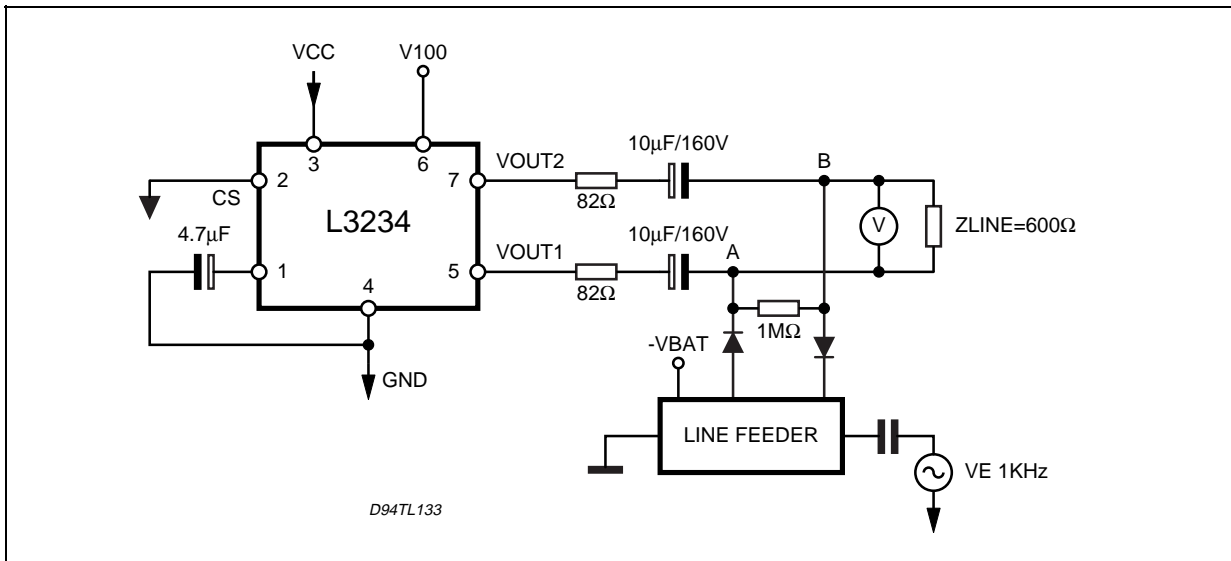

Figure 6.

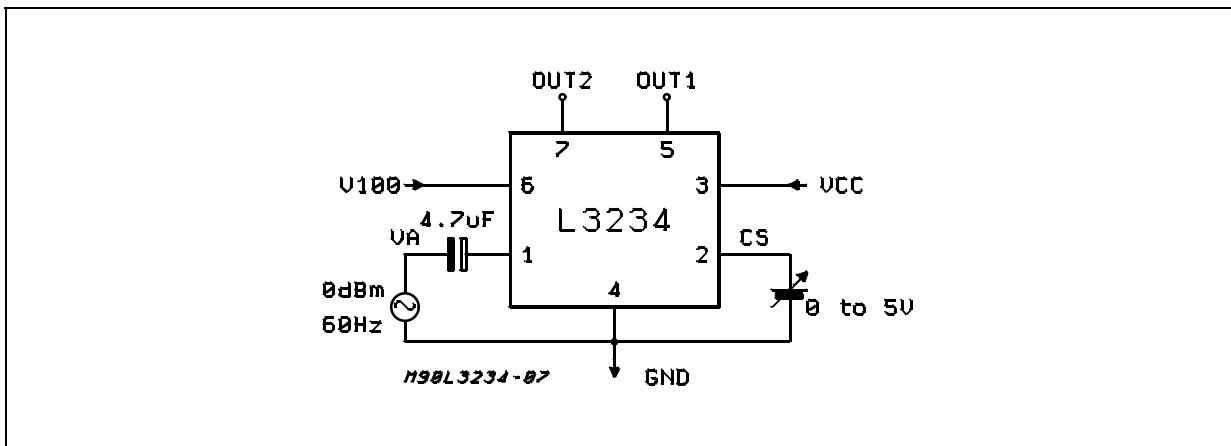
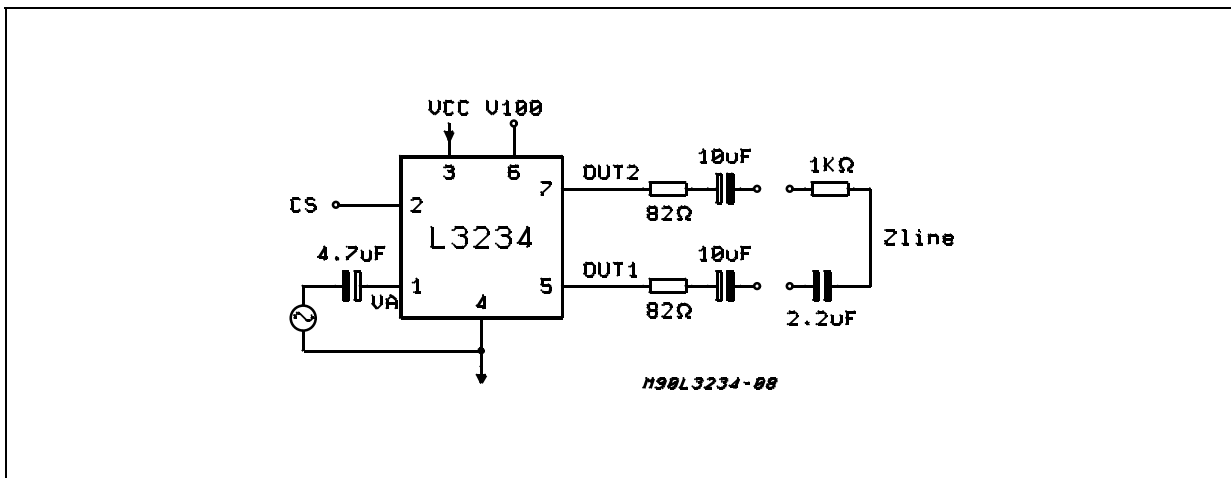

Figure 7.



TEST CIRCUITS (continued)
Figure 8.

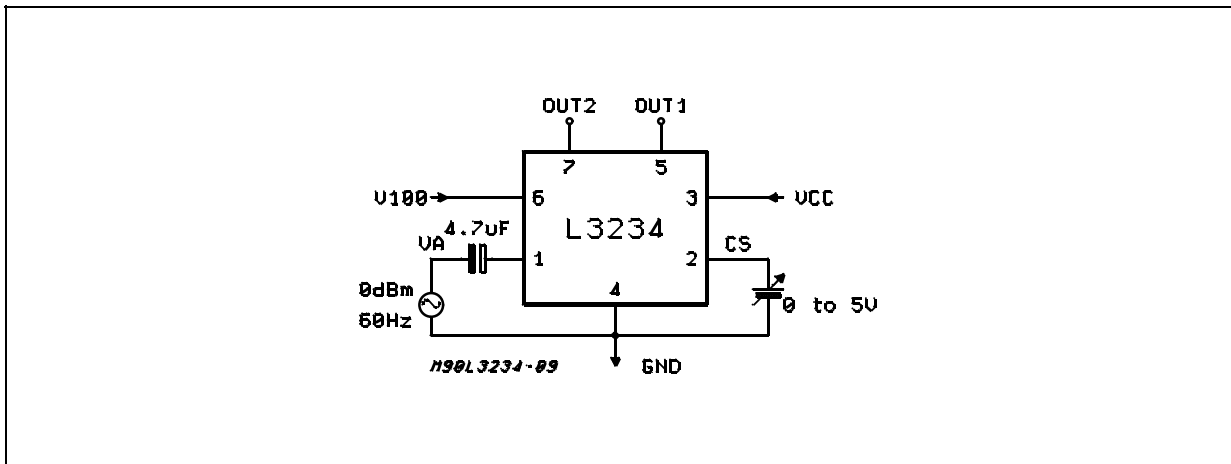

Figure 9.

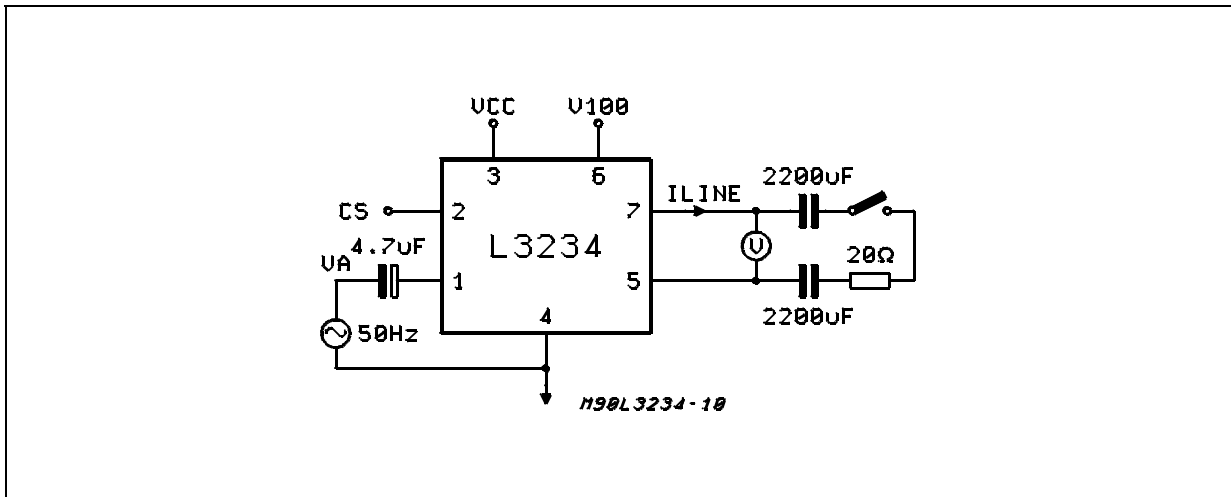
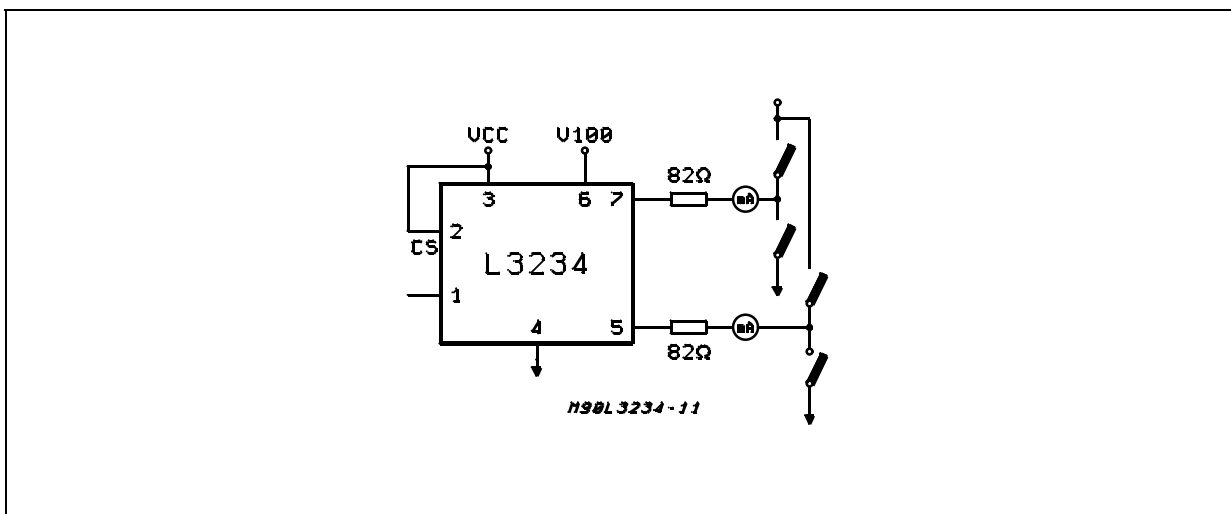

Figure 10.



L3235N Subscriber Line Interface Circuit

DESCRIPTION

Circuit description

The L3235N Subscriber Line Interface Circuit (SLIC) is a bipolar integrated circuit in 60V technology optimized for PABX application.

The L3235N supplies a line feed voltage with a current limitation which can be modified by an external resistor (RLIM).

The SLIC incorporates loop currents, ground key detection functions with an externally programmable constant time.

The two to four wires and four to two wires voice frequency signal conversion is performed by the L3235N and the line terminating and the balancing impedances are externally programmable.

The device integrates an automatic power limitation circuit. In short loop condition the extra power is dissipated on one external transistor (Text).

This approach allows to assembly the L3235N in a low cost standard plastic TQFP44 package.

The chip is protected by thermal protection at $T_j = 150^{\circ}\text{C}$.

The SLIC is able to give a power up command for Combo in off hook condition and an enable logic for solid state ringing injector L3234.

The L3235N package is 44 pin plastic TQFP.

The L3235N has been designed to operate together with L3234 performing complete BORSHT function without any electromechanical ringing relay (see the application circuit fig. 16).

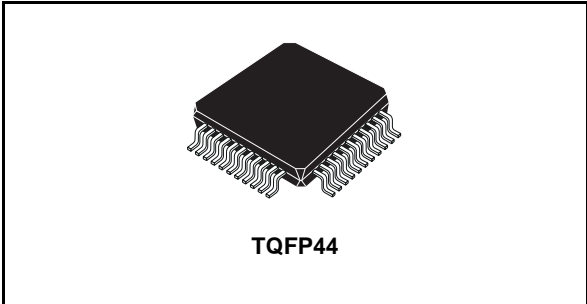

PIN CONNECTION

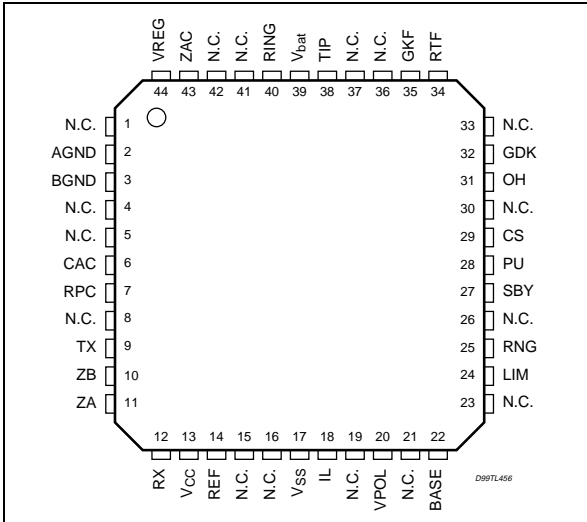

ABSOLUTE MAXIMUM RATINGS

Symbol	Parameter	Value	Unit
V_{BAT}	Battery Voltage	-54	V
V_{CC}	Positive Supply Voltage	5.5	V
V_{SS}	Negative Supply Voltage	-5.5	V
T_j	Max. Junction Temperature	150	$^{\circ}\text{C}$
T_{stg}	Storage Temperature	-55 to +150	$^{\circ}\text{C}$

OPERATING RANGE

Symbol	Parameter	Min.	Max.	Unit
V_{BAT}	Battery Voltage	-52	-24	V
V_{CC}	Positive Supply Voltage	4.75	5.25	V
V_{SS}	Negative Supply Voltage	-5.25	-4.75	V
T_{op}	Operating Temperature for L3235N	0	70	$^{\circ}\text{C}$
T_j	Max Junction Operating Temperature		130	$^{\circ}\text{C}$

Note: Operating ranges define those limits between which the functionality of the device is guaranteed.



THERMAL DATA

Symbol	Description	Value	Unit
$R_{th\ j-amb}$	Thermal Resistance Junction-ambient	Max	60 °C/W

PIN DESCRIPTION

N°	Name	Description
1,4,5,8, 15,16,19 ,21,23, 26,30,33 ,36,37, 41,42	NC	Not Connected
2	AGND	Analog/Digital Ground.
3	BGND	Battery Ground. This is the Reference for the Battery Voltage (note 1).
6	CAC	AC Current Feedback Input.
7	RPC	External Protection Resistors AC Transmission Compensation.
9	TX	Four Wire Transmitting Amplifier Output.
10	ZB	Non Inverting Operational Input Inserted in the Hybrid Circuit for 2W to 4W Conversion. The Network Connected from this Pin to Ground shall be a copy of the Line Impedance.
11	ZA	VRX Output Buffer 2W to 4W Conversion.
12	RX	High Impedance Four Wire Receiving Input.
13	V _{CC}	Positive 5V Supply Voltage.
14	REF	Voltage Reference Output; a Resistor Connected to this pin sets the Internal Bias Current.
17	V _{SS}	Negative 5V Supply Voltage.
18	IL	Transversal Line Current Feedback Divided by 50.
20	VPOL	Non Inverting Operational Input to Implement DC Character.
22	BASE	Driver for External Transistor Base.
24	LIM	Voltage Reference Output; a Resistor Connected to this Pin Sets the Value of Line Current Limitation.
25	RNG	Ringing Logic Input from Line Card Controller.
27	SBY	Stand by Logic Input (SBY = 1 Set Line Current Limitation at 3mA).
28	PU	Power u.p Logic Output for the Codec Filter. (PU = 0 means Codec Filter Activated)
29	CS	Ring Injector Enable for L3234 Output. (CS = 1 means L3234 Ringing Injection Enable).
31	OH	Hook Status Logic Output (OH = 0 means off hook).
32	GDK	Ground Key Status Logic Output (GDK = 0 means Ground Key on).
34	RTF	Time Constant Hook Detector Filter Input.
35	GKF	Time Constant GK Detector Filter Input.
38	TIP	Tip Wire of 2 Wire Line Interface.
39	V _{bat}	Negative Battery Supply Input.
40	RING	RING wire of 2 Wire Line Interface.
43	ZAC	Non Inverting Input of the AC Impedance Synthesis Circuit.
44	VREG	Emitter Connection for the External Transistor.

Note 1:

AGND and BGND pins must be tied together at a low impedance point (e.g. at card connector level).

L3235N FUNCTIONAL DIAGRAM

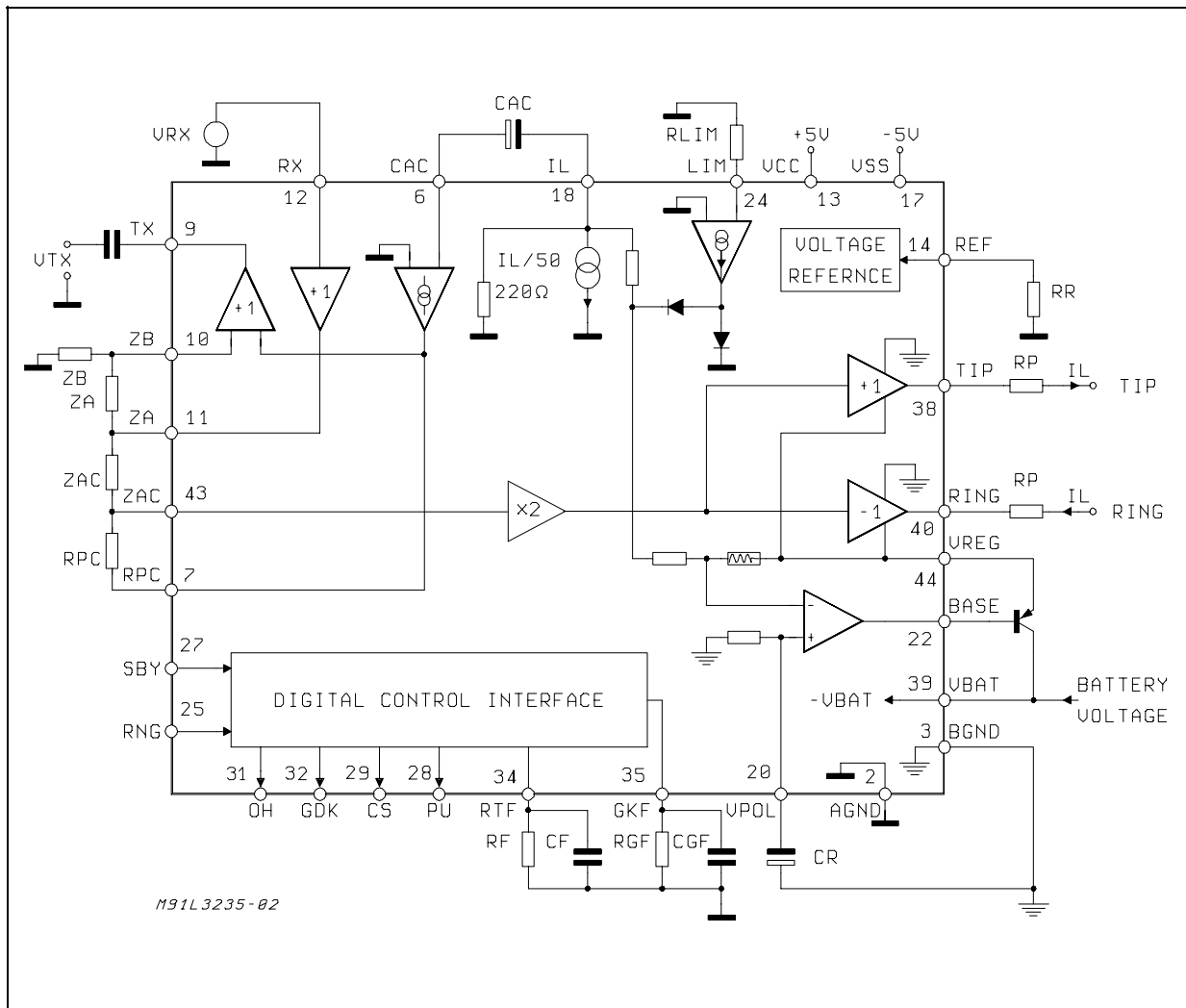

FUNCTIONAL DESCRIPTION

DIGITAL INTERFACE

The different operating modes of the L3235N are programmed through a digital interface based on two input pins:

- 1) SBY input programs the stand-by or Active/Ringing modes.
- 2) RNG input programs the ringing ON/OFF activation condition for the L3234.

The L3235N digital interface has four output pins :

- 1) OH provides the on hook/off hook or ring trip informations (active low).
- 2) GDK provides the ground key on/off information (active low).
- 3) PU must be connected to the enable input pin of CODEC/FILTER devices like ETC 5054/57

and automatically activates this device when in active mode off-hook is detected or when ringing mode is selected.

- 4) CS output must be connected to the CS enable input of the solid state ringing injector L3234.

In this way the L3234 will be enabled when ringing mode is programmed and will be automatically disabled when the ring trip condition will be detected reducing the ringing signal disconnection time after ring trip.

The table 1 here below resumes the different operation modes and the relative logic output signals.

The two current detection (hook and GND key) have internal fixed threshold. Externally it is possible to program their time constant through two R-C components connected respectively to pin 26 (RTF) and pin 27 (GKF).

Table 1.

OPERATING MODE	INPUT PIN		LINE STATUS		OUTPUT PIN			
	SBY	RNG	0: ON HOOK 1: OFF HOOK	0: NO GND KEY 1: GND KEY ON	OH	GDK	PU	CS
ACTIVE	0	0	0	0	1	1	1	0
	0	0	0	1	0	0	0	0
	0	0	1	0	0	1	0	0
	0	0	1	1	0	0	0	0
RINGING	0	1	0	0	1	1	0	1
	0	1	0	1	0	0	0	0(*)
	0	1	1	0	0	1	0	0(*)
	0	1	1	1	0	0	0	0(*)
STAND-BY	1	0	X	X	1	1	1	0
	1	1	X	X	1	1	0	1

(*)This status is latched and doesn't change until RNG turn to 0

OPERATING MODES

Stand-By (SBY = 1 and RNG = 0)

In Stand-By mode the L3235N limits the DC Loop current to 3 mA.

In this mode all the AC circuits are active and all the AC characteristics are the same as in Active Mode.

Also the two Line Current detectors (hook and GND key) are active but due to the loop current limited to 3 mA they will not be activated.

This mode is useful in emergency condition when it is very important to limit the system power dissipation.

Ring Mode (SBY = 0 and RNG = 1)

When ringing mode is selected "CS" pin is set to 1 in order to activate the L3234 ringing injector.

See L3234 for detailed description.

Ring trip is detected by means of the same internal circuitry used for off-hook detection.

An off-hook delay time lower than $\frac{1}{2} F_{RING}$ should be selected. (see ext. components list).

When ring trip is detected "CS" is automatically set to "0" allowing in this way a quick ringing disconnection.

After Ring trip detection the Card Controller must set the L3235N in active mode to remove the internal latching of the "CS" information.

Active mode (SBY = 0 and CS1 = 0)

In Active mode the L3235N has the DC characteristics show in Fig.13

The DC characteristics of L3235N has two different feeding conditions:

1) Current Limiting Region : (short loop) the DC impedance of the SLIC is very high (>20 Kohm) therefore the system works as a current generator. By the ext. resistor RLIM connected at pin 19 it is possible to program limiting current values from 20 mA to 70 mA.

2) Voltage source region (long loop).

The DC impedance of the L3235N is almost equal to zero therefore the system works like a voltage generator with in series the two external protection resistors Rp.

When a limiting current value higher than 40 mA is programmed the device will automatically reduce to 40 mA the loop current for very short loop.

This is done in order to limit the maximum power dissipation in very short loop to values lower than 2W for the external transistor and lower than 0.5W for the L3235N itself.

This improve the system reliability reducing the L3235N power dissipation and therefore the internal junction temperature.

Figure 11: DC characteristic in Active Mode with two different values of limiting current (30mA and 70mA).

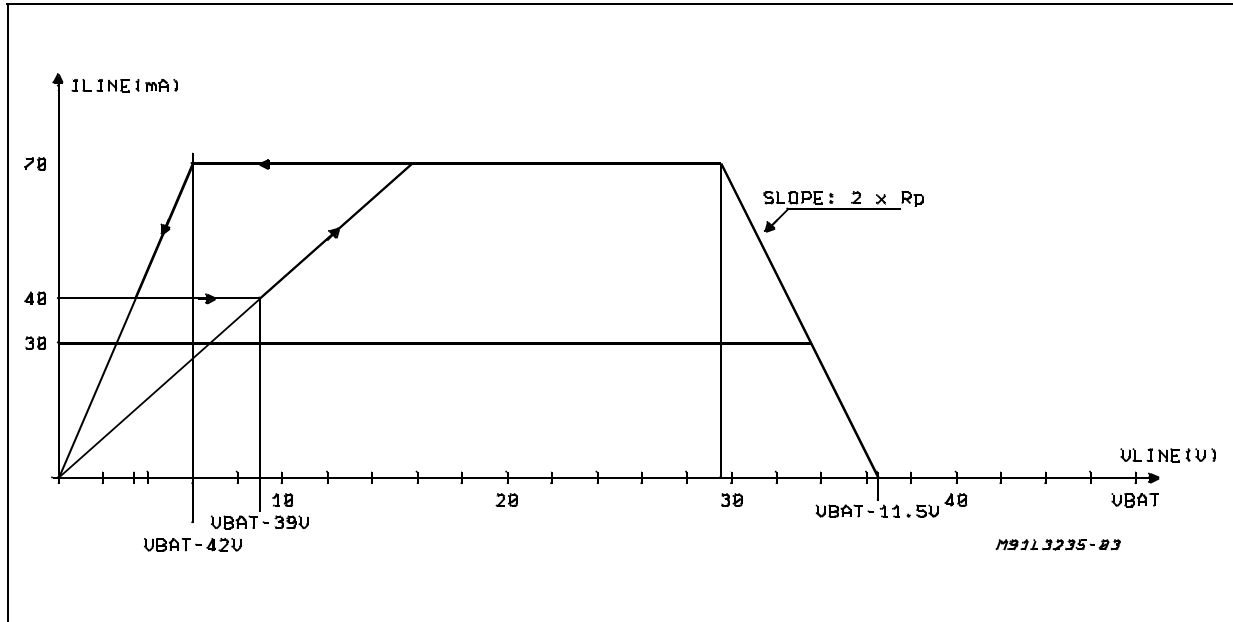
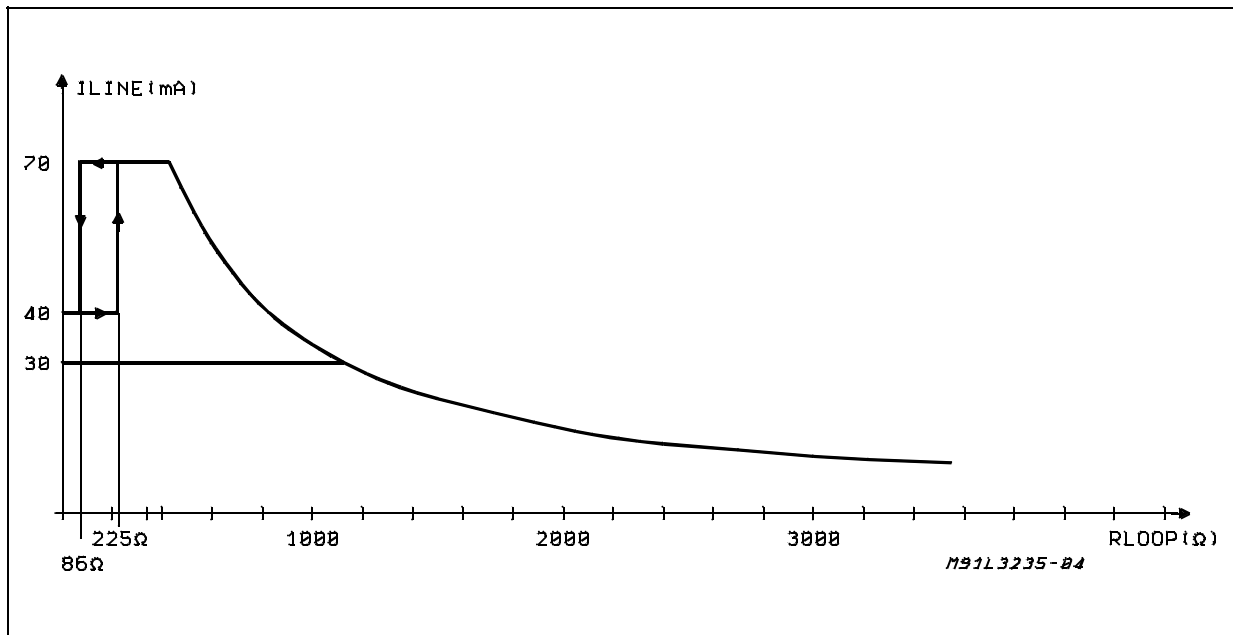

Figure 12: Line current versus loop resistance with two different values of limiting current (30mA and 70mA)



AC transmission circuit stability

To ensure stability of the feedback loop shown in block diagram form in figure 13 two capacitors are required. Figure 14 includes these capacitors Cc and Ch.

AC - DC separation

The high pass filter capacitor C_{AC} provides the separation between DC circuits and AC circuits. A C_{AC} value of 100mF will position the low end frequency response 3dB break point at 7Hz,

$$f_{sp} = \frac{1}{2\pi \cdot 220\Omega \cdot C_{AC}}$$

Figure 13.

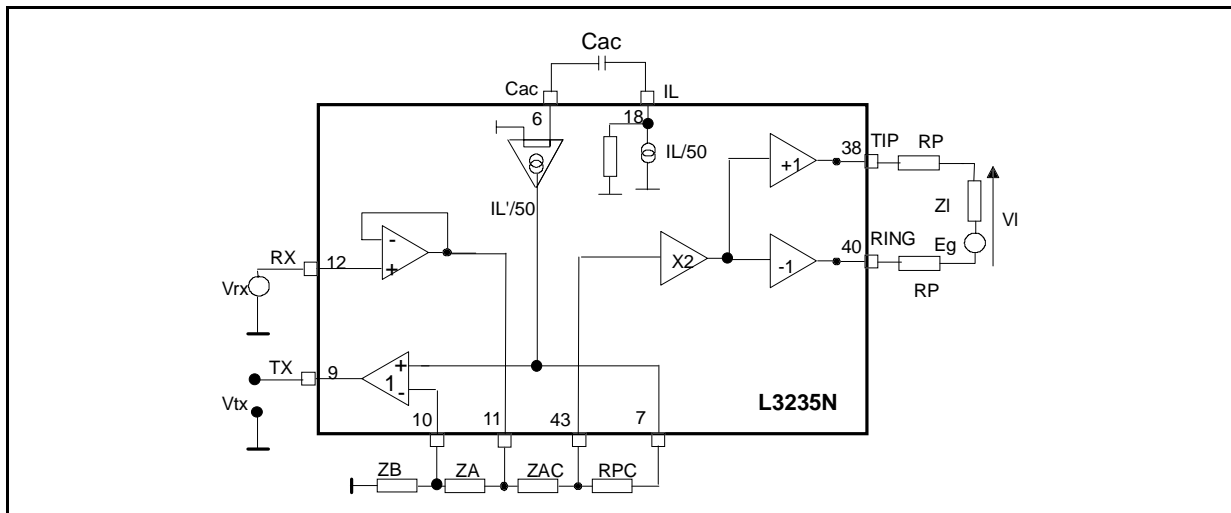

AC Characteristic

A simplified AC model of the transmission circuits is shown in figure 13

Where:

- V_{rx} is the received signal
- V_{tx} is the transmitted signal
- V_l is the AC transversal voltage in line
- E_G is the line open circuit AC voltage
- Z_L is the line impedance
- R_P are the protection resistors
- Z_B is the line impedance balancing network
- Z_A is the SLIC impedance balancing network
- Z_{AC} programmable AC line termination impedance
- R_{PC} used for external protection resistors insertion loss compensation
- $I/50$ is the AC transversal current divided by 50
- CAC AC feedback current decoupling

AC behavior

The AC path simplified formulas, that are valid when $I/50'$ is equal to $I/50$, are the following :

- Two wire impedance
The impedance presented to the two wire by the SLIC including the protection resistors R_P and defined as Z_s is equal to :
 $Z_s = Z_{AC}/12.5 + 2R_P$
i.e. with $Z_{AC} = 6250 \text{ W}$ and $R_p = 50 \text{ W}$
 $Z_s = 600 \text{ W}$
- Two wire to four wire gain
The transmission gain , G_{tx} , of the SLIC is

equal to :

$$G_{TX} = V_{tx} / V_l$$

$$G_{TX} = 0.25 * (R_{PC} + Z_{AC}) / (25R_P + Z_{AC})$$

using $R_{PC} = 25R_P$, as recommended to compensate the protection resistor R_P ,
 $G_{TX} = 0.25$ (-12 dB)

- Four wire to two wire gain
The receiver gain , G_{rx} , of the SLIC is equal to:

$$G_{RX} = V_l / V_{rx}$$

$$G_{RX} = 50Z_l / (Z_{AC} + 12.5(Z_l + 2R_P))$$

using $Z_{AC} = 12.5(Z_s - 2R_P)$ and assuming $Z_l = Z_s$ we have the following gain:

$$G_{RX} = 2 \quad (+6 \text{ dB})$$

- Hybrid function
The transhybrid loss, Th_l , is equal to:

$$Th_l = V_{tx} / V_{rx}$$

$$Th_l = Z_B / (Z_A + Z_B) - (Z_{AC} + R_{PC}) / (Z_{AC} + 12.5(2R_P + Z_l))$$

using $Z_{AC} = 12.5(Z_s - 2R_P)$ and $R_{PC} = 25R_P$ we have the following relation:

$$Th_l = Z_B / (Z_A + Z_B) - Z_l / (Z_l + Z_s)$$

To maximize the hybrid attenuation the impedance must be matched, $Z_A / Z_B = Z_s / Z_l$, to guarantee $Th_l = 0$.

From the above relation it is evident that if Z_s is equal to the Z_l in Th_l test the impedance Z_A and Z_B can be substituted by two equal resistors.

L3234 - L3235N

External components list for L3235N

To set the SLIC into operation the following parameters have to be defined:

- The AC SLIC impedance at line terminals "Zs" to which the return loss measurements is referred. It can be real (typ. 600Ω) or complex.
- The equivalent AC impedance of the line "Zl" used for evaluation of the trans-hybrid loss performance (2/4 wire conversion). It is usually a complex impedance.
- The value of the two protection resistors Rp in series with the line termination.

Once, the above parameters are defined, it is possible to calculate all the external components using the following table. The typical values has been obtained supposing: Zs = 600Ω; Zl = 600Ω; Rp = 50Ω

Name	Suggested Value	Function	Formula
R _F C _F	39KΩ 390nF	Delay Time On-hook Off-hook	$\tau = 0.69 \cdot C_F \cdot 39K\Omega$ (1)
R _{GF} C _{GF}	39KΩ 390nF	Delay Time GK Detector	$\tau = 0.69 \cdot C_{GF} \cdot 39K\Omega$
R _R	51KΩ	Bias Set	
R _{LIM}	8.4KΩ to 33KΩ	Ext. Current Limit. Progr.	$R_{LIM} = \frac{564}{I_{LIM} - 3mA}$
CR	4.7μF 6.3 V 30%	Negative Battery Filter	$C_{AC} = \frac{1}{2\pi \cdot 16K\Omega \cdot f_p}$
R _P	50	Protection Resistors	$47 \leq R_P \leq 100\Omega$ (2)
R _T	1MΩ 20%	Termination Resistor	
C _{AC}	100μF 6.3V 20%	DC/AC current feedback splitting	$C_{AC} = \frac{1}{2\pi \cdot 220\Omega \cdot f_{sp}}$
R _{PC}	1250Ω 1%	R _P insertion loss compensation	$R_{PC} = 12.5 \cdot (2R_P)$
Z _{AC}	6250Ω 1%	2W AC Impedance programmation	$Z_{AC} = 12.5 \cdot (Z_S - 2R_P)$
C _C	470pF 20%	AC Feedback compensation	$f_1 = 300KHz \quad C_C = \frac{1}{2\pi f_1 \cdot 25R_P}$
Z _{AS}	12500Ω 1%	Slic Impedance Balancing Net.	$Z_{AS} = 25 \cdot (Z_S - 2R_P)$
R _{AS}	2500Ω 1%		$R_{AS} = 25 \cdot (2R_P)$
Z _B	15KΩ 1%	Line impedance Balancing Net.	$Z_B = 25 \cdot Z_l$
C _H	220pF 20%	C _C Transybrid loss Compensation	$C_H = C_C \cdot \frac{Z_{AC}}{Z_{AS}}$
C _{TX}	4.7μF 30%	DC Decoupling Tx Output	$C_{TX} = \frac{1}{6.28 \cdot f_p \cdot Z_{load}}$
D1, D2	1N4007	Line Rectifier	
Text	(3)	External Transistor	$P_{Diss} \geq 2W, V_{CEO} \geq 60V$ $H_{FE} \geq 40, I_C \geq 100mA$ $V_{BE} < 0.8V @ 100mA$
CV _{SS} ; CV _{DD}	100nF	±5V supply filter	
C _{VB}	100nF/100V	V _{BAT} supply filter	

Notes:

1) For proper operation Cf should be selected in order to verify the following conditions:

A) $c_f > 150nF$

B) $\tau < 1/2 \cdot f_{RING}$

f_{RING}: Ringing signal frequency

2) For protection purposes the R_P resistor is usually splitted in two part R_{P1} and R_{P2}, with R_{P1} ≥ 30Ω.

3) ex: BD140; MJE172; MJE350.... (SOT32 or SOT82 package available also for surface mount). For low power application (reduced battery voltage) BCP53 (SOT223 surface mount package) can be used. Depending on application environment an heatsink could be necessary.

L3234 - L3235N

ELECTRICAL CHARACTERISTICS (Test condition: refer to the test circuit of the fig. 16; $V_{CC} = 5V$, $V_{SS} = -5V$, $V_{bat} = -48V$, $T_{amb} = 25^{\circ}C$, unless otherwise specified)

Note: Testing of all parameters is performed at $25^{\circ}C$. Characterization, as well as the design rules used allow correlation of tested performance with actual performance at other temperatures. All parameters listed here are met in the range $0^{\circ}C$ to $+70^{\circ}C$.

Symbol	Parameter	Test Condition	Min.	Typ.	Max.	Unit	Fig.
--------	-----------	----------------	------	------	------	------	------

STAND-BY

V_{is}	Output Voltage at TIP/RING pins	$I_{LINE} = 0$	35.7		39	V	
I_{LCC}	Short Circuit Current	Stand-by, SBY = 1	2	3	4	mA	

DC OPERATION

V_{IP}	Output Voltage at TIP/RING pins	$I_{LINE} = 0$ $I_{LINE} = 50mA$	35.7 35.2		39 39	V V	
I_{lim}	Current Progr.	$I_{lim} \text{ Prog.} = 70mA$	63	70	77	mA	
I_{lim}	Current Progr.	$8.4K\Omega < R_{LIM} < 33K\Omega$	20		70	mA	
I_O	On-hook Threshold				5	mA	
I_f	Off-hook Threshold		10			mA	
I_{gk}	GK Detector Threshold		10		17	mA	
Gklim	Ground Key Current Limitation	RING to BGND	13		22	mA	
Gkov	Ground Key Threshold Overloop	Gklim-Ilgk	1			mA	
I_{max}	Max. Output Current at TIP/RING	$I_{lim} = 70mA$	90		140	mA	
$I_{V_{CC}}$	Supply Current from V_{CC}	$I_{line} = 0$		6.2	8	mA	
$I_{V_{SS}}$	Supply Current from V_{SS}	$I_{line} = 0$		1.6	2.1	mA	
$I_{V_{bat}}$	Supply Current from V_{bat}	$I_{line} = 0$		2.8	3.6	mA	

AC OPERATION

Z_{Tx}	Sending Output Impedance	pin 9 (Tx)			10	Ω	
Z_{Rx}	Receiving Input Impedance	pin 12 (Rx)	1			M Ω	
R_l	2W Return Loss	$f = 300$ to $3400Hz$	22	36		dB	A1
Thl	Trans Hybrid Loos	$f = 300$ to $3400Hz$	22	36		dB	A2
G_s	Sending Gain	$f = 1020Hz$ $I_l = 20mA$	-11.9	-12.1	-12.3	dB	A3
G_{sf}	Flatness	$f = 300$ to $3400Hz$	-0.2		0.2	dB	
G_{sl}	Linearity	-20dB to 10dBm	-0.2		0.2	dB	
G_r	Receiving Gain	$f = 1020Hz$ $I_l = 20mA$	5.8	6	6.2	dB	A4
G_{rf}	Flatness	$f = 300$ to $3400Hz$	-0.2		0.2	dB	
G_{rl}	Linearity	-20dBm to +4dBm	-0.2		0.2	dB	
N_{p4W}	Psoph. Noise at Tx			-90	-78	dBmp	
N_{p2W}	Psoph. Noise at Line			-82	-70	dBmp	
S_{vrr}	Relative to V_{bat} versus Line Terminal versus Tx Terminal	$f = 1020Hz$ $V_S = 100mV_{pp}$		-30 -24		dB dB	A5
S_{vrr}	Relative to V_{CC} and V_{SS} versus Line Terminal versus Tx Terminal	$f = 1020Hz$ $V_S = 100mV_{pp}$		-20 -14		dB dB	
L_{tc}	L/T Conversion measured at line Terminals	$f = 300$ to 3400 $I_{line} = 20mA$	49 53(*)			dB dB	A6
T_{ic}	T/L Conversion Measured at Line Terminals	$f = 300$ to 3400 $I_{line} = 20mA$	46(*)			dB	A7

(*) Selected parts L3235NC

ELECTRICAL CHARACTERISTICS (continued)

Symbol	Parameter	Test Condition	Min.	Typ.	Max.	Unit	Fig.
V_{il}	Input Voltage at Logical "0"	Input SBY, CS1	0		0.8	V	
V_{ih}	Input Voltage at Logical "1"	Input SBY, CS1	2		5	V	
I_{il}	Input Current at Logical "0"	Input SBY, CS1			10	μ A	
I_{ih}	Input Current at Logical "1"	Input SBY, CS1			10	μ A	
V_{ol}	Output Voltage at Logical "0"	$I_{out} = 1\text{mA}$ $I_{out} = 10\mu\text{A}$			0.5 0.4	V V	
V_{oh}	Output Voltage at Logical "1"	$I_{out} = 10\mu\text{A}$ $I_{out} = 1\text{mA}$	4 2.7			V V	

Figure 14: Test Circuit

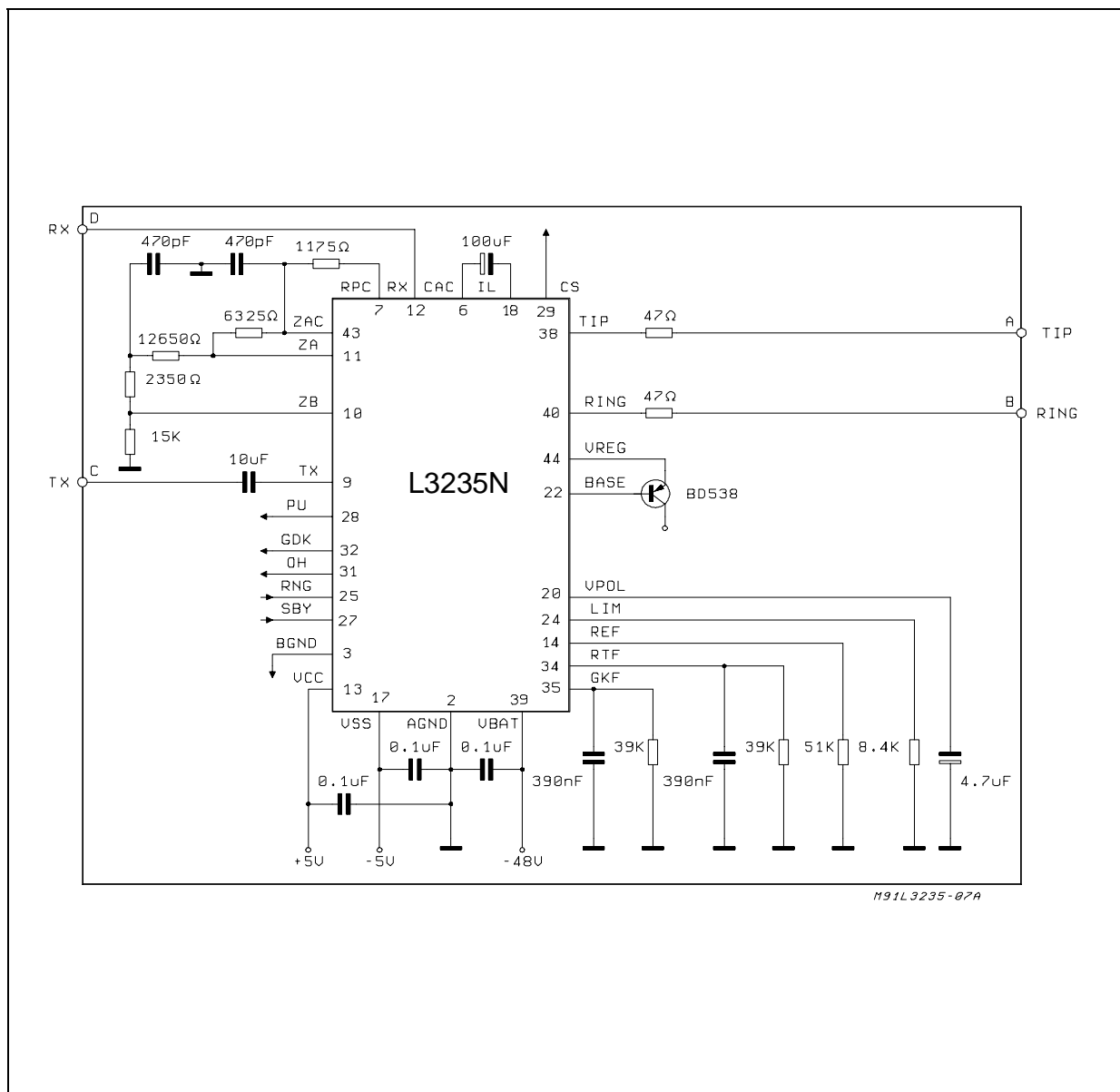

L3234 - L3235N

APPENDIX A

L3235N TEST CIRCUITS

Referring to the test circuit reported in fig 16 you can find the proper configuration for the main measurements.

In particular:

A-B: Line terminals

C: Tx sending output on 4W side

D: Rx receiving input on 4W Side

Figure A1: 2W Return Loss

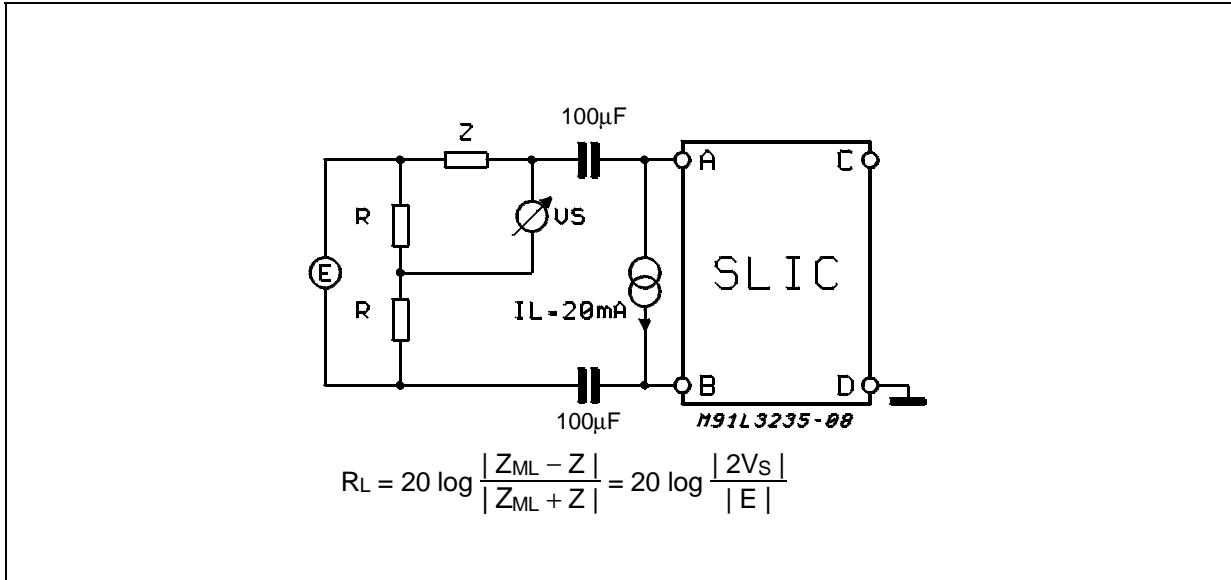

Figure A2: Trans-hybrid Loss

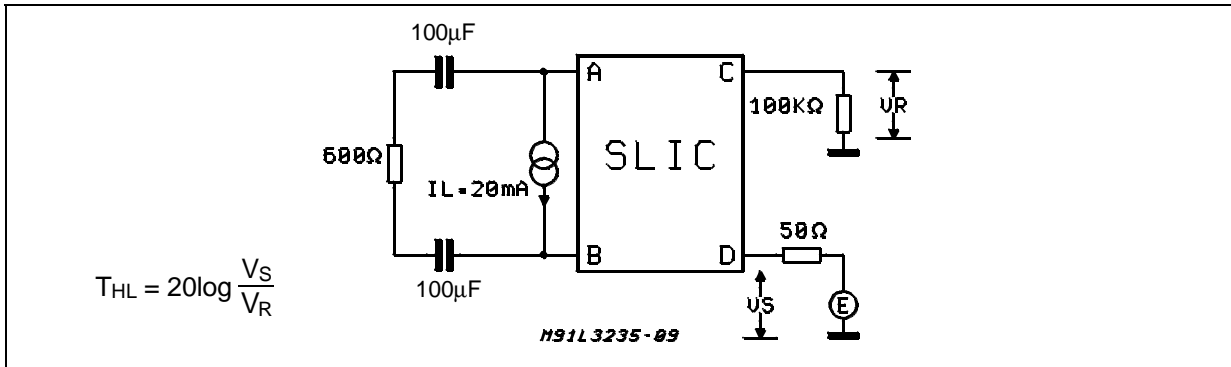
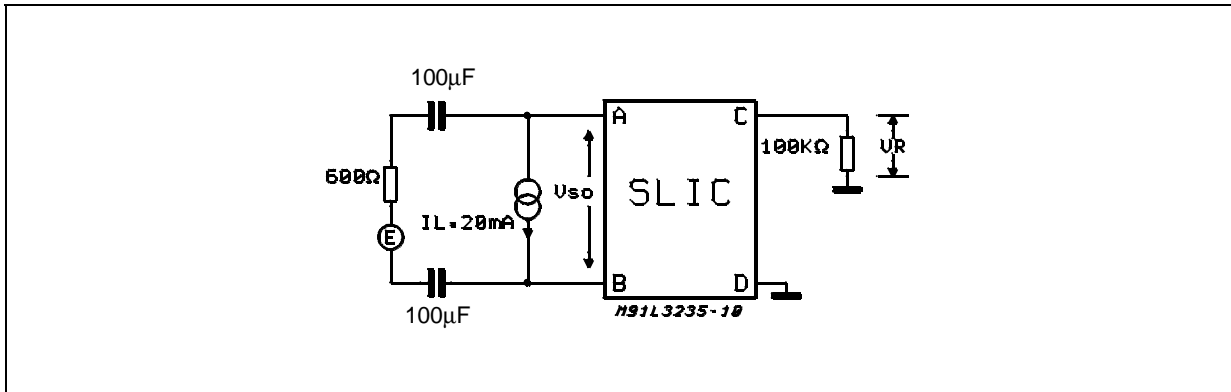

Figure A3: Sending Gain



TEST CIRCUITS (continued)
Figure A4: Receiving Gain

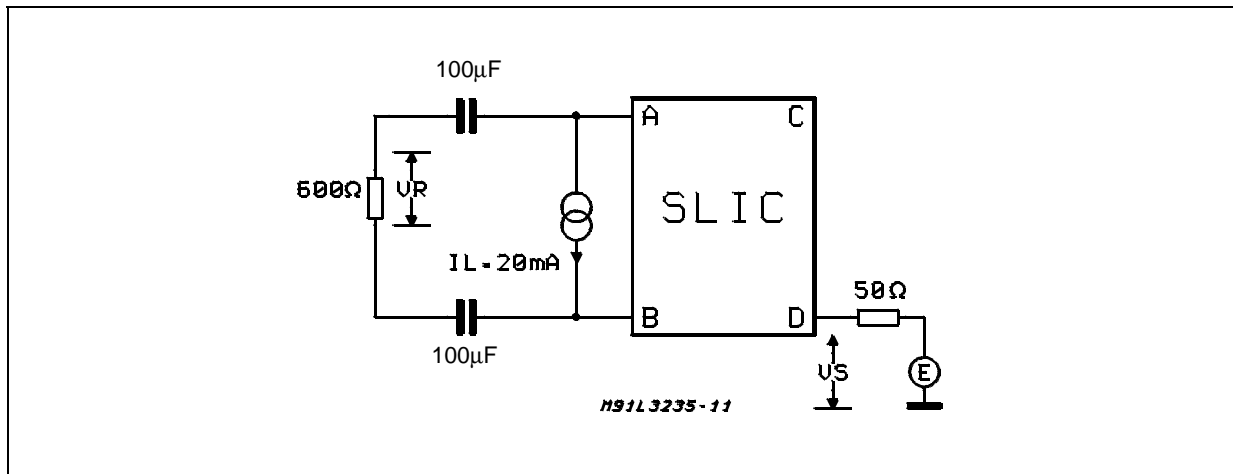

Figure A5: SVRR Relative to Battery Voltage VB

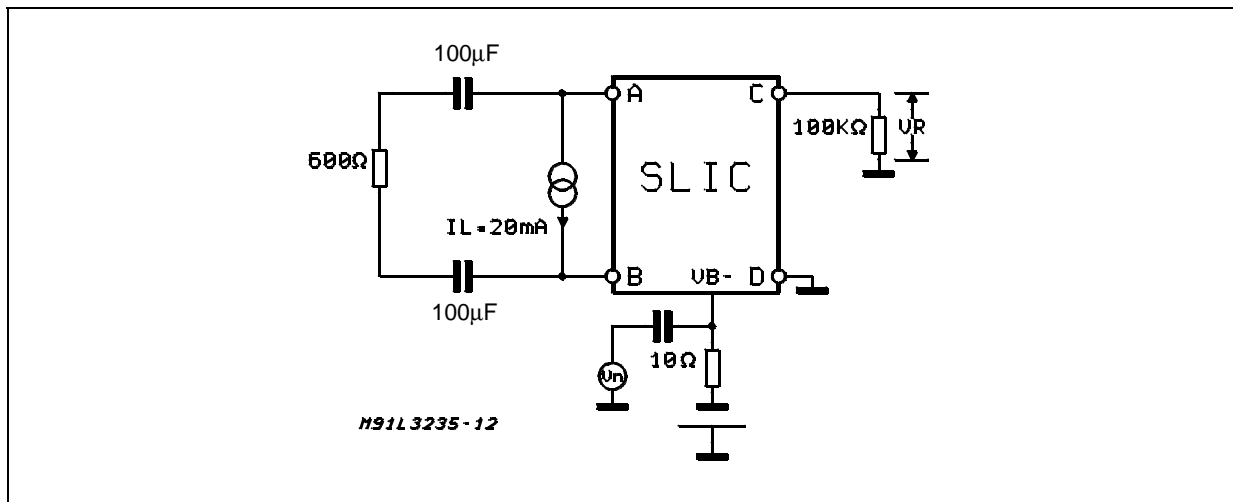

Figure A6: Longitudinal to Transversal Conversion

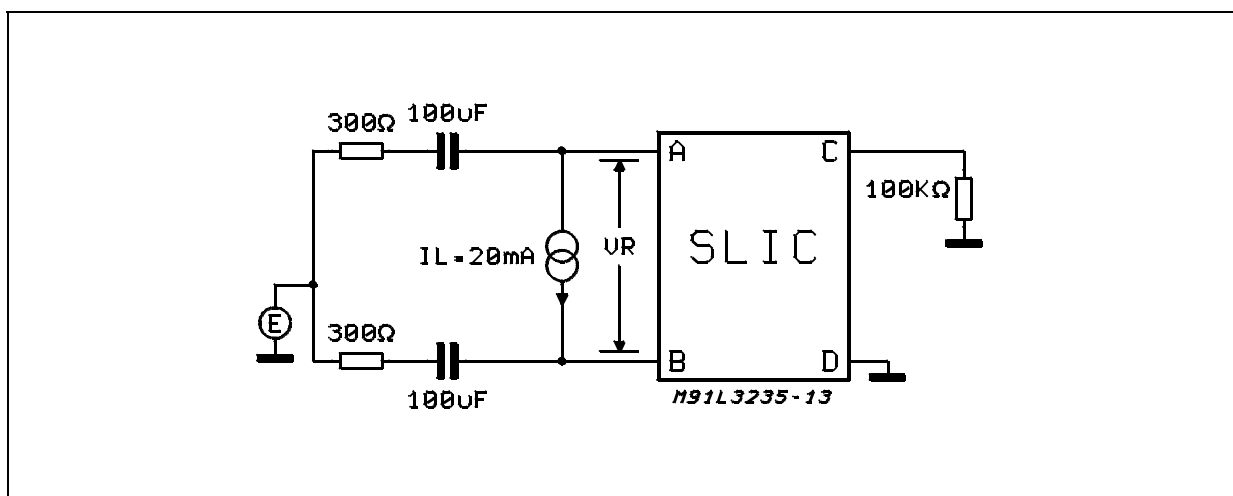
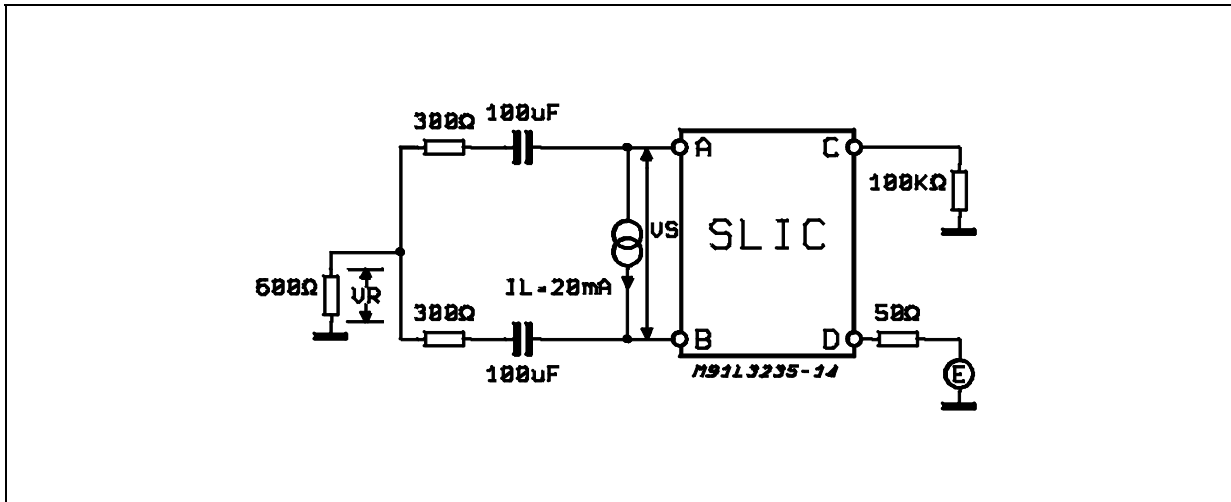

Figure A7: Transversal to Longitudinal Conversion



APPENDIX B

LAYOUT SUGGESTIONS

Standard layout rules should be followed in order to get the best system performances:

- 1) Use always 100nF filtering capacitor close to the supply pins of each IC.
- 2) The L3235N bias resistor (RR) should be connected close to the corresponding pins of L3235N (REF and AGND).

DIM.	mm			inch		
	MIN.	TYP.	MAX.	MIN.	TYP.	MAX.
A			4.8			0.189
C			1.37			0.054
D	2.4		2.8	0.094		0.110
D1	1.2		1.35	0.047		0.053
E	0.35		0.55	0.014		0.022
F	0.6		0.8	0.024		0.031
F1			0.9			0.035
G	2.41	2.54	2.67	0.095	0.100	0.105
G1	4.91	5.08	5.21	0.193	0.200	0.205
G2	7.49	7.62	7.8	0.295	0.300	0.307
H2	9.2		10.4	0.362		0.409
H3	10.05		10.4	0.396		0.409
L	4.6		5.05	0.181		0.198
L1	3.9	4.1	4.3	0.153	0.161	0.170
L2	6.55	6.75	6.95	0.253	0.265	0.273
L3	5.9	6.1	6.3	0.232	0.240	0.248
L5	2.6	2.8	3	0.102	0.110	0.118
L6	15.1		15.8	0.594		0.622
L7	6		6.6	0.236		0.260
M	0.17		0.32	0.007		0.012
V2	8°(max)					
Dia	3.65		3.85	0.144		0.152

OUTLINE AND MECHANICAL DATA

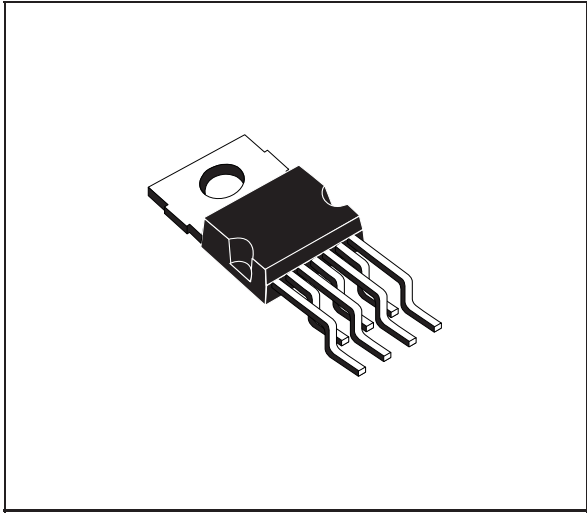

Heptawatt (Surface Mount)

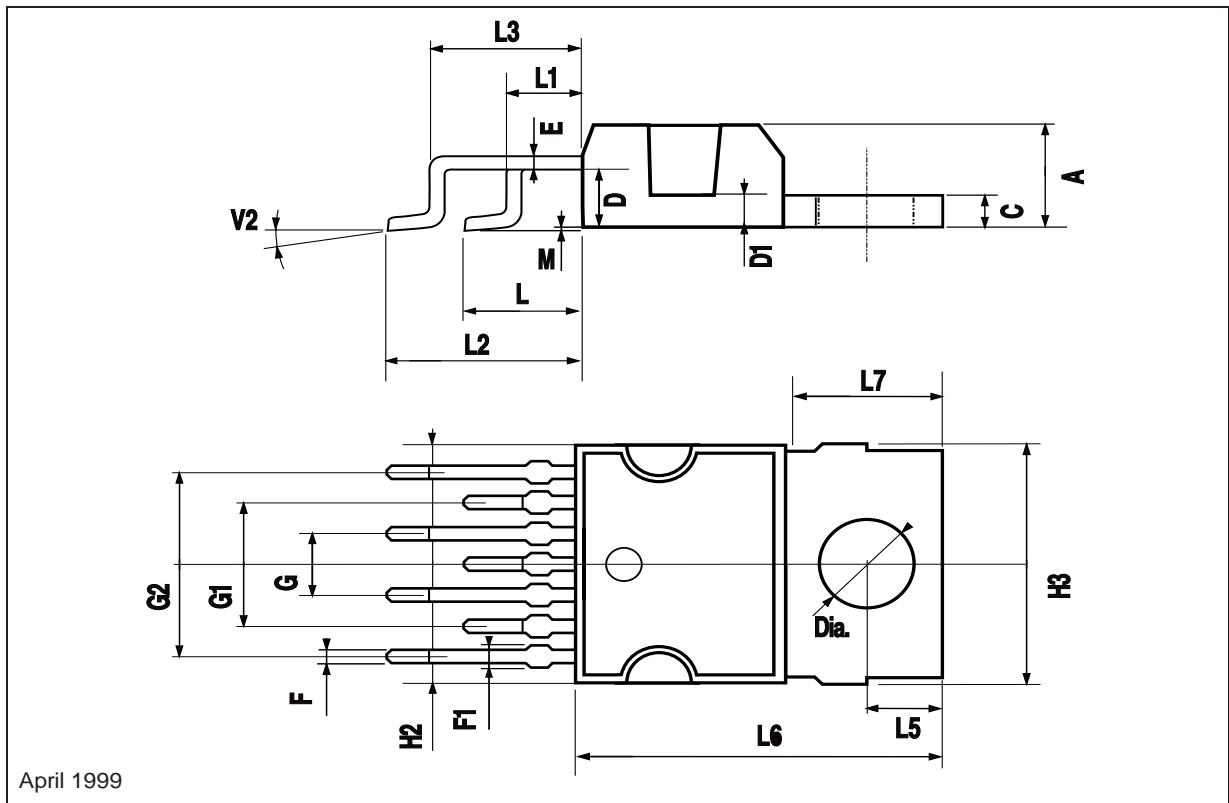

April 1999

L3234 - L3235N

DIM.	mm			inch		
	MIN.	TYP.	MAX.	MIN.	TYP.	MAX.
A			1.60			0.063
A1	0.05		0.15	0.002		0.006
A2	1.35	1.40	1.45	0.053	0.055	0.057
B	0.30	0.37	0.45	0.012	0.014	0.018
C	0.09		0.20	0.004		0.008
D		12.00			0.472	
D1		10.00			0.394	
D3		8.00			0.315	
e		0.80			0.031	
E		12.00			0.472	
E1		10.00			0.394	
E3		8.00			0.315	
L	0.45	0.60	0.75	0.018	0.024	0.030
L1		1.00			0.039	
K	0°(min.), 3.5°(typ.), 7°(max.)					

OUTLINE AND MECHANICAL DATA

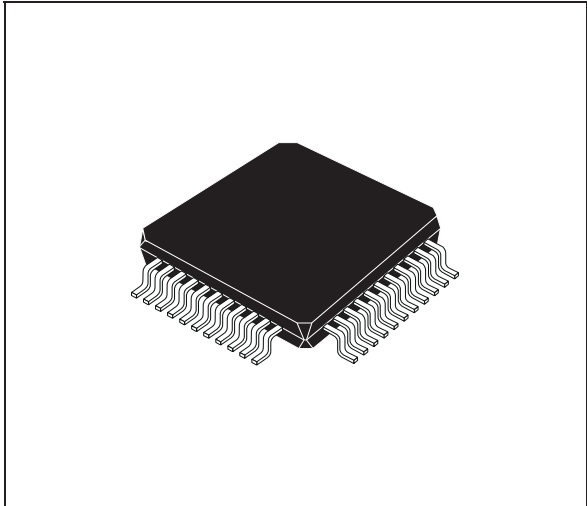

TQFP44 (10 x 10)

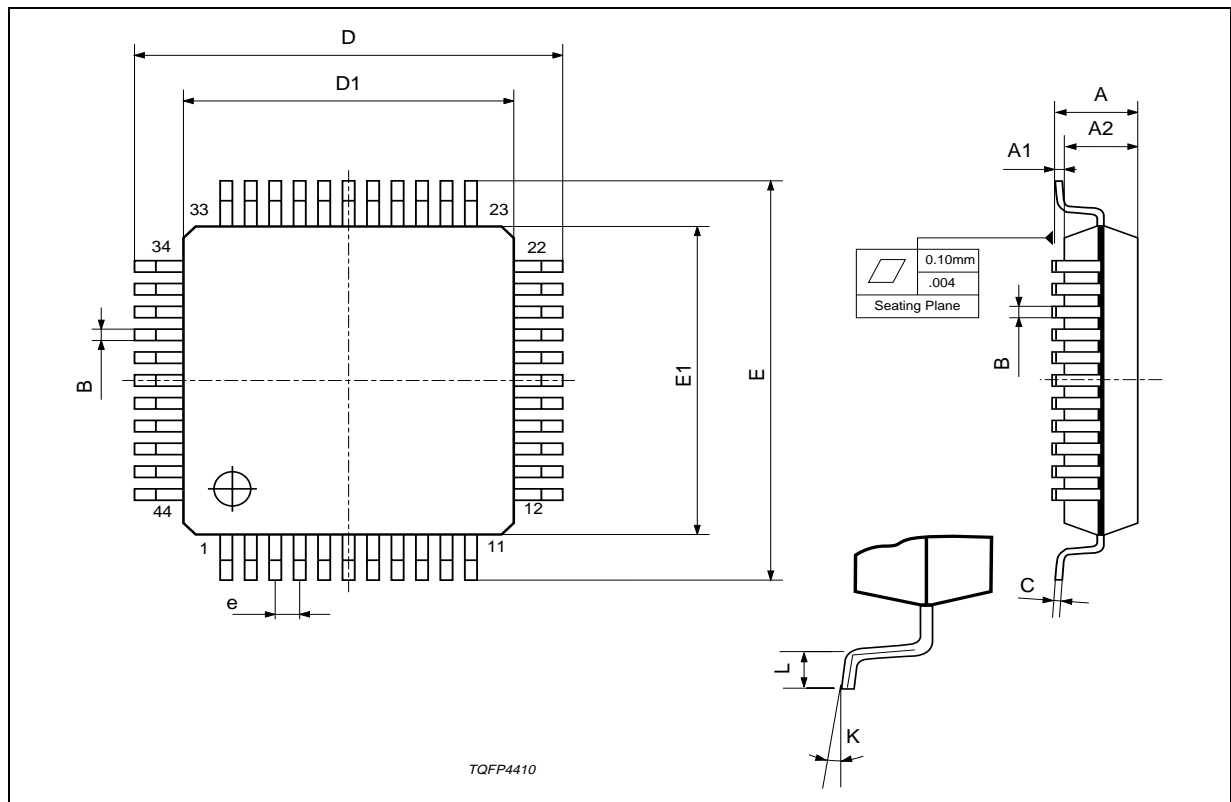

Information furnished is believed to be accurate and reliable. However, STMicroelectronics assumes no responsibility for the consequences of use of such information nor for any infringement of patents or other rights of third parties which may result from its use. No license is granted by implication or otherwise under any patent or patent rights of STMicroelectronics. Specification mentioned in this publication are subject to change without notice. This publication supersedes and replaces all information previously supplied. STMicroelectronics products are not authorized for use as critical components in life support devices or systems without express written approval of STMicroelectronics.

The ST logo is a registered trademark of STMicroelectronics

© 2001 STMicroelectronics – Printed in Italy – All Rights Reserved

STMicroelectronics GROUP OF COMPANIES

Australia - Brazil - Canada - China - Finland - France - Germany - Hong Kong - India - Israel - Italy - Japan - Malaysia - Malta - Morocco - Singapore - Spain - Sweden - Switzerland - United Kingdom - United States.

<http://www.st.com>