

NOTES: UNLESS OTHERWISE SPECIFIED

- 1 SEE DRAWING NO 27331 FOR P.C.B. HOLE REQUIREMENTS.
- 2 SEE DETAIL 'W' FOR ORIENTATION OF CLIP.
- 3 SEE DETAIL 'U' FOR RECOMMENDED BLADE SIZE & TIP CONFIGURATION (MIN BLADE WIDTH, .50 / 12.7).
- 4. TOOLING:
 SINGLE INSERTION 107-43937-01
 SINGLE INSERTION W/SIZING 107-43946-01
 DOUBLE INSERTION W/SIZING 107-43946-02
 REMOVAL 107-43924-01.
- 5 PERMANENTLY MARKED PER MIL-STD-202 METHOD 215 WITH MOTOROLA PART NO AND REV LEVEL, DATE CODE, LEFT OR RIGHT AND WIN. EL. LOCATED IN THIS AREA.

WED CATALOG NO	MOTOROLA P/N & REV.
121-29265-1L	3909977S01A
121-29265-1R	3909977S02A

- 6 INSTALLATION SEATING: FLUSH TO .005 ABOVE P.C. BOARD.
- 7 CLIP, ITEM 3, MAY OVERHANG BASE, ITEM 2, BY .015/0.38 MAX.

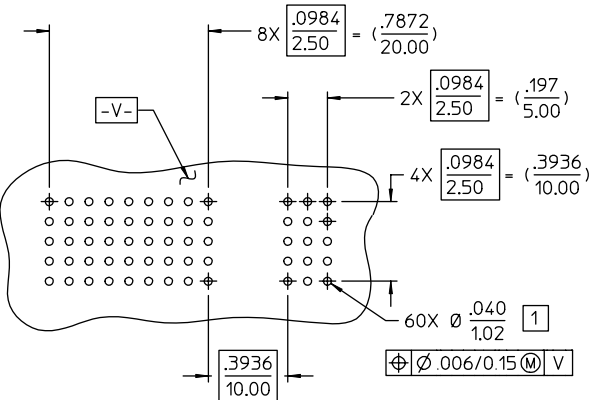
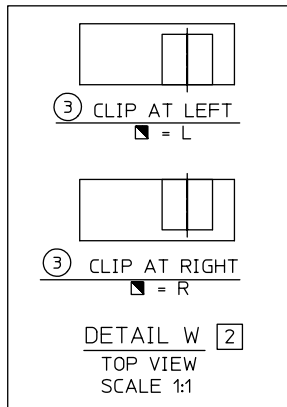

RECOMMENDED P.C.B. HOLE PATTERN

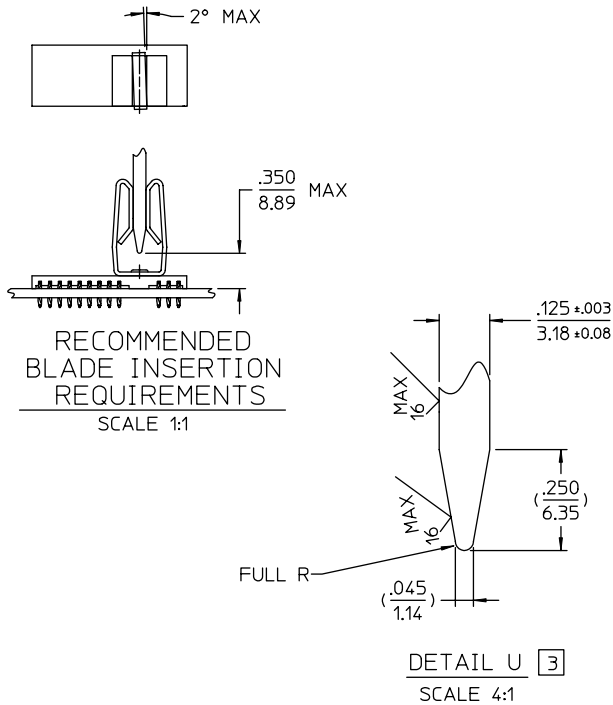

RECOMMENDED BLADE INSERTION REQUIREMENTS
SCALE 1:1

DETAIL U [3]
SCALE 4:1

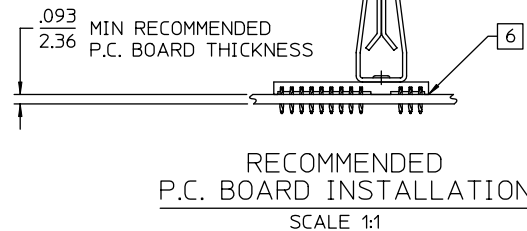

RECOMMENDED P.C. BOARD INSTALLATION
SCALE 1:1

POWER CLIP CODE ORDER

121 - 29265 - [] [] [] []

STEP 1 SERIES CODE []

STEP 2 POWER CLIP CATALOG NO []

STEP 3 CURRENT RATING []

STEP 4 CONNECTOR STYLE []

STEP 5 CONNECTOR STYLE []

CODE	* DESCRIPTION
1	130 AMP. , 60 CONTACTS
2	30 AMP. , 25 CONTACTS
3	60 AMP. , 30 CONTACTS

CODE	DESCRIPTION [2]
L	LEFT CLIP
R	RIGHT CLIP

CODE	DESCRIPTION
BLANK	TIN-LEAD OVER NICKEL
T	PURE TIN OVER NICKEL

REV	DESCRIPTION	BY DATE	APPD
H	REVISED PER ECR8711	C.W.B. 10/26/05	V.B.H.

SPECIFICATIONS

MATERIALS & FINISHES

- 1 C-Press® Contacts — Copper Alloy - C72500 Tin-Lead Plate over Nickel
- 2 Base — Copper Alloy - C36000 Tin-Lead Plate Over Nickel
- 3 Clip — Copper Alloy - C66400 Tin-Lead Plate Over Nickel
- 4 Rivet — Copper Alloy - C27000 Tin Plate

PERFORMANCE CHARACTERISTICS

- 3 Insertion Force (Max Gage) — 10 Lbs. Max.
- 3 Withdrawl Force (Min Gage) — 3 Lbs. Min.
- Temperature Rise — 30°C Max
- * Current — See STEP 3 in Code Order above
- Voltage Drop — 30 millivolts Max
- Contact Resistance — 20 milliohms Max
- C-Press® Contact Performance:
 Insertion Force — 200 lbs. Max per row of 5 contacts
 Retention Force — 40 lbs. Min per row of 5 contacts

PER ASME Y14.5M-1994 UNLESS OTHERWISE SPECIFIED: DIMENSIONS ARE IN INCHES OR INCHES/MM TOLERANCES: DECIMALS: .XX ± .02 / 0.5 .XXX ± .007 / 0.18 ANGLES: ± X° SCALE: 2:1		NORTHROP GRUMMAN 82 Barnes Industrial Road North Wallingford, CT 06492	
CUSTOMER DRAWING		TITLE POWER CLIP (C-PRESS)®	
DRAWN J.M.G. 10/19/95	DATE 10/19/95	APPROVED W.P.M. 05/05/97	DATE 05/05/97
APPROVED J.BACCEI 05/06/97	DATE 05/06/97	APPROVED E.J.C. 05/05/97	DATE 05/05/97
C		29265	SHT. 1 OF 2 REV. H

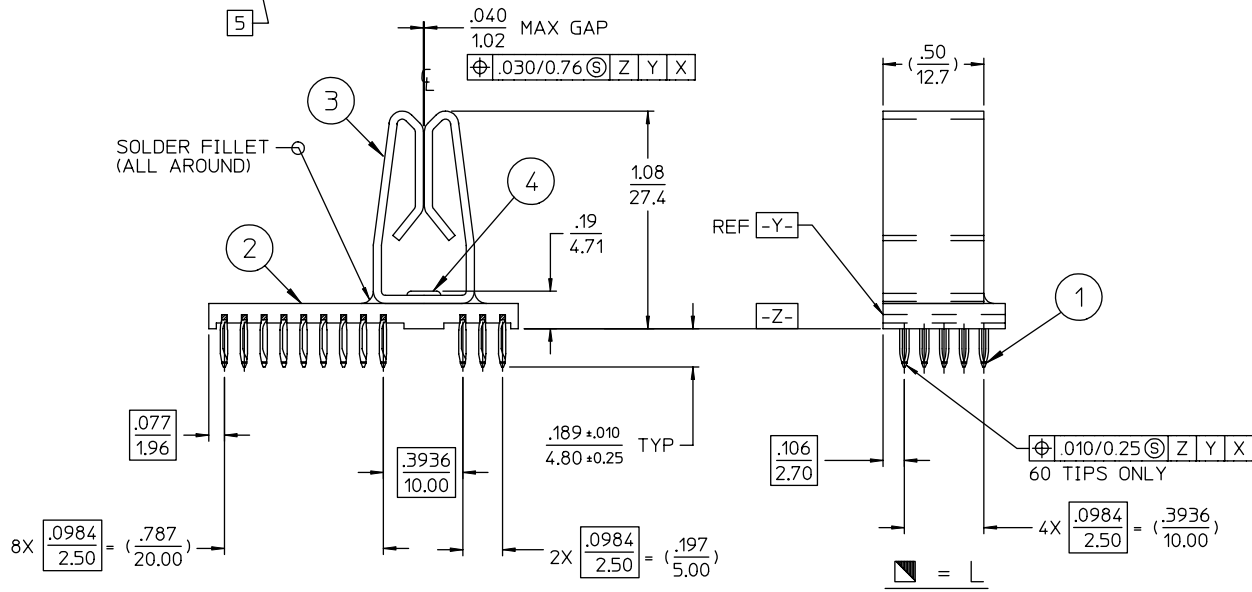
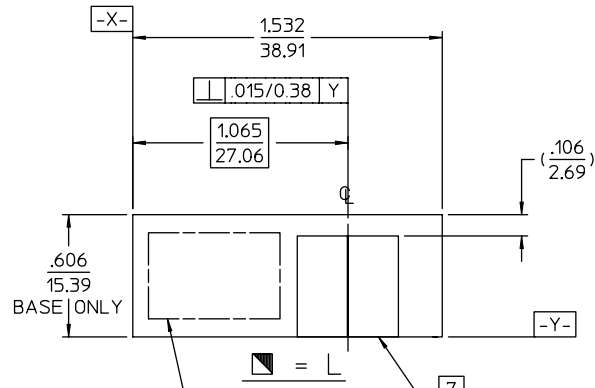
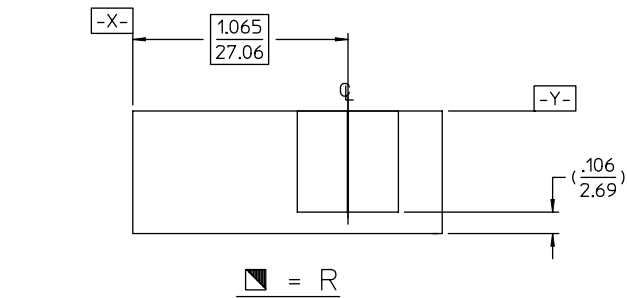

CATALOG NO 121-29265-1 SHOWN
130 AMP

REV	DESCRIPTION	BY DATE	APPD
G	REVISED PER ECR# 8711	CMB 10/26/05	V8H

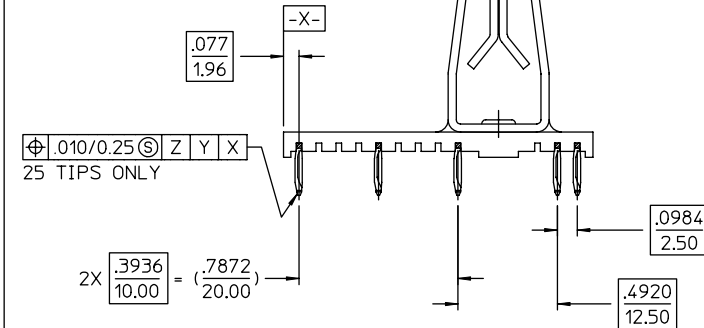

CATALOG NO 121-29265-2 SHOWN
30 AMP
SAME AS CATALOG NO 121-29265-1 EXCEPT AS SHOWN

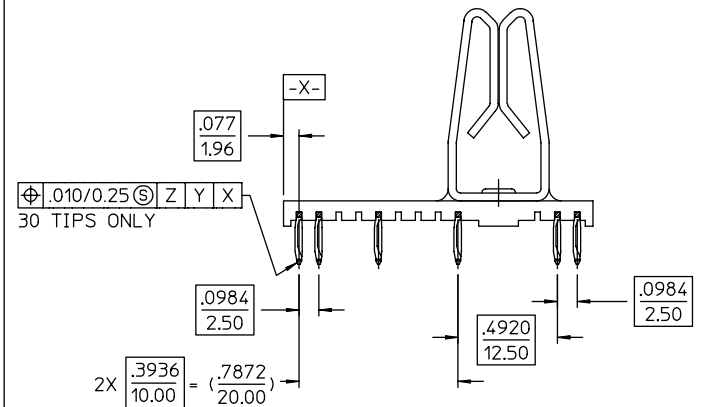

CATALOG NO 121-29265-3 SHOWN
60 AMP
SAME AS CATALOG NO 121-29265-1 EXCEPT AS SHOWN

PER ASME Y14.5M-1994
UNLESS OTHERWISE SPECIFIED:
DIMENSIONS ARE IN INCHES OR INCHES/MM
TOLERANCES:
DECIMALS: .XX ± .02 / 0.5
.XXX ± .007 / 0.18
ANGLES: ± X°
SCALE: 2:1

NORTHROP GRUMMAN

Winchester Electronics

82 Barnes Industrial Road North
Wallingford, CT 06492

CUSTOMER DRAWING



TITLE POWER CLIP (C-PRESS) (R)

DRAWN	DATE	APPROVED	DATE
J.M.G.	10/20/95	W.P.M.	05/05/97
APPROVED	DATE	APPROVED	DATE
J.BACCEI	05/06/97	E.J.C.	05/05/97

C	29265	SHT. 2 OF 2	REV. H
---	-------	-------------	--------