



and **Ultra ADC Series**

32-bit High Performance Audio ADC Product Brief

The **SABRE³² ADC** series is the world's highest performance 32-bit analog-to-digital (A/D) converter solution targeted for consumer applications such as audio pre-amplifier, audio processor, A/V receiver and professional audio applications such as recording systems, mixer consoles and digital audio workstations.

Part	Description	DNR (dB-A)	THD+N (dB)	32-bit Digital Filter	8-band Biquad Filter	I2S/SPDIF Output	Sample Rate	Package
ES9102	SABRE³² Reference 32-bit Stereo/Mono ADC	127 (Mono) 124 (Stereo)	-120 (Mono) -118 (Stereo)	Programmable	Programmable	Yes	Up to 384kHz	48LQFP
ES9112	SABRE³² Ultra 32-bit Stereo ADC	124	-112	Programmable	Programmable	Yes	Up to 384kHz	28SOP

Using the ESS proprietary 32-bit Hyperstream™ ADC architecture, the **SABRE³² Reference ADC** delivers an unprecedented DNR of 127dB and THD+N of -120dB in mono mode (or DNR of 124dB and THD+N of -118dB in stereo mode), a performance level that will satisfy the most demanding audio enthusiasts.

For highest performance, the **SABRE³² ADC** series implements a 32-bit programmable decimation filter and outputs the full 32-bit resolution in I2S mode, or 24-bit resolution in SPDIF mode. A digital high-pass filter is available for DC removal. Additionally, a programmable 8-band biquad filter is implemented for RIAA or custom equalization. The **SABRE³² ADC** series supports synchronous SPDIF or I2S master/slave output, or asynchronous I2S slave output relative to the master clock for up to 384kHz sample rate and consumes less than 200mW.

FEATURE

BENEFIT

32-bit Hyperstream™ ADC architecture <table border="1" data-bbox="110 1255 548 1354"> <thead> <tr> <th></th> <th>Reference</th> <th>Ultra</th> </tr> </thead> <tbody> <tr> <td>DNR (dB-A)</td> <td>Up to 127</td> <td>124</td> </tr> <tr> <td>THD+N (-dB)</td> <td>Up to 120</td> <td>112</td> </tr> </tbody> </table>		Reference	Ultra	DNR (dB-A)	Up to 127	124	THD+N (-dB)	Up to 120	112	Unprecedented dynamic range and ultra low distortion
	Reference	Ultra								
DNR (dB-A)	Up to 127	124								
THD+N (-dB)	Up to 120	112								
Build-in mono mode (Reference only)	Mono (with additional performance) or stereo configuration without external components									
32-bit Programmable decimation (FIR) filter <ul style="list-style-type: none"> ○ Built-in sharp or low-group delay filters, or ○ User customizable characteristics 	Customizable FIR decimation filters for any application									
Programmable 8-band biquad filter <ul style="list-style-type: none"> ○ Built-in RIAA filter ○ User customizable characteristics 	Customizable equalization for any application									
Programmable Digital High-pass filter	Eliminates input DC offset									
Up to 384kHz sampling rate	Compatible with DVD-audio and professional applications									
I2C or hardware based control	Configured by microcontroller or used standalone									
Flexible SPDIF/I2S digital output modes	Synchronous SPDIF or I2S master/slave output, or asynchronous I2S slave output relative to master clock									
Low power in a small package <ul style="list-style-type: none"> ○ <200mW power consumption 	Simplifies power supply design									

SABRE³² ADC Series Product Brief



FUNCTIONAL BLOCK DIAGRAM

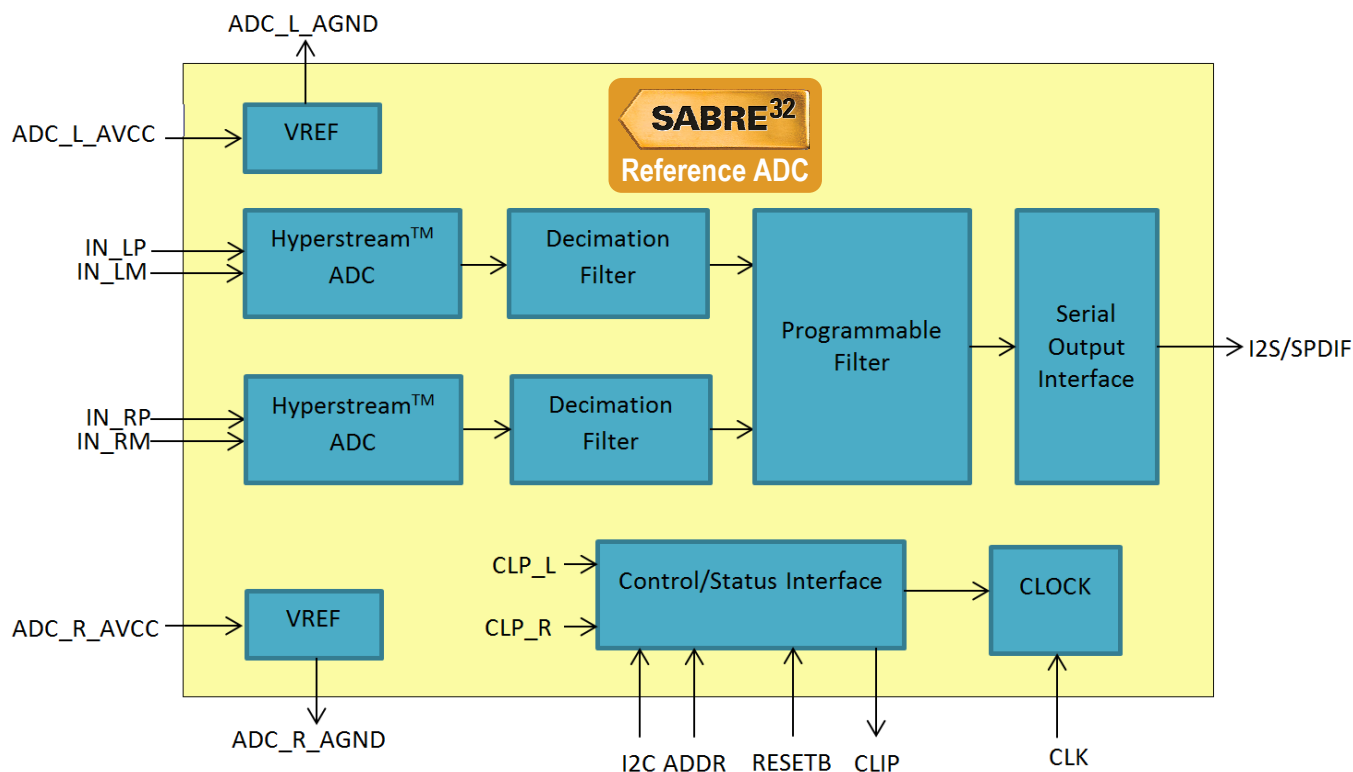

APPLICATIONS

- Professional recording systems
- Studio mixing console
- Digital audio workstations
- Audio/Video receivers
- Audio preamplifiers
- Audio processor

No part of this publication may be reproduced, stored in a retrieval system, transmitted, or translated in any form or by any means, electronic, mechanical, manual, optical, or otherwise, without the prior written permission of ESS Technology, Inc. ESS Technology, Inc. makes no representations or warranties regarding the content of this document. All specifications are subject to change without prior notice. ESS Technology, Inc. assumes no responsibility for any errors contained herein. U.S. patents pending.