

NOTES:

1. STANDARD PART SET UP AS ASP.
2. Ⓢ REPRESENTS A CRITICAL DIMENSION.
3. MAXIMUM BURR ALLOWANCE: .038 [.0015].
4. MINIMUM PUSHOUT FORCE: 2.22N [.5LB].
5. PARTS TO BE PACKAGED IN TRAYS.

REVISION

| | | |
|---|------------|------------|
| 0 | DF | D FRALEY |
| 2/9/2008 | ECN-85889 | |
| ISSUE FOR REVIEW | | |
| A | SM | D Fletcher |
| 5/1/2008 | ECN-90087 | |
| RELEASE FOR PRODUCTION | | |
| B | MM | D Fletcher |
| 6/11/2008 | ECN-92573 | |
| BOM CHG ERF8-011-05.0-DV-L TO ERF8-011-05.0-DV-SL | | |
| C | JB | D FRALEY |
| 11/10/2008 | ECN-100474 | |
| BOM CHG ERF8-011-05.0-DV-SL TO ERF8-011-05.0-DV-L | | |
| D | JB | Z Paden |
| 3/2/2010 | ECN-128251 | |
| SMT2, RECOMMENDED PCB LAYOUT: DEL 4.90 (TYP), ADD 1.80 (TYP), CHG ⌀0.83±0.02 TO ⌀0.83±0.05, CHG 5.61 TO 5.60, ADD NOTE "TO BE SOLDERED USING PASTE-IN-HOLE TECHNOLOGY", RECOMMENDED STENCIL LAYOUT: CHG ⌀1.59 (2 PLCS) TO ⌀2.247 (2 PLCS) | | |

| | |
|---------------------------------|-------|
| ACCEPTANCE OF DRAWING | _____ |
| ACCEPTED WITH DEVIATIONS LISTED | _____ |
| DATE: | _____ |
| COMPANY: | _____ |
| CUSTOMER SIGNATURE | _____ |
| PRINTED NAME | _____ |
| PHONE No: | _____ |
| FAX No: | _____ |

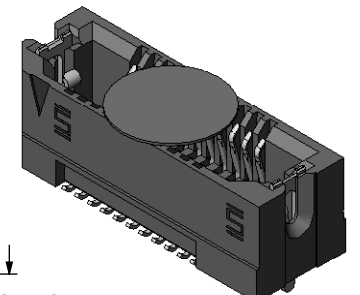
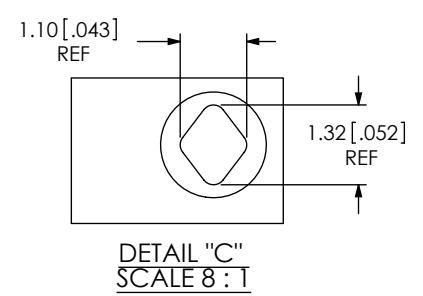
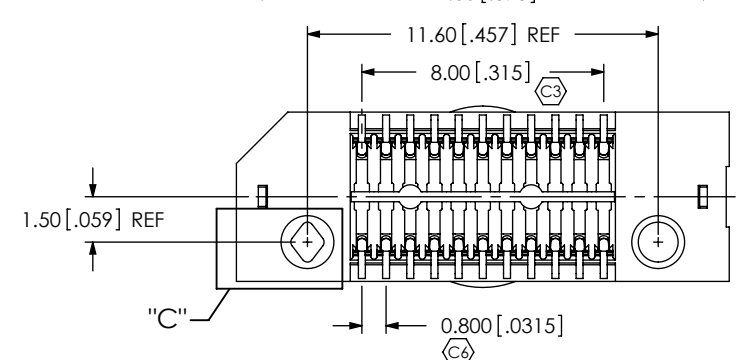
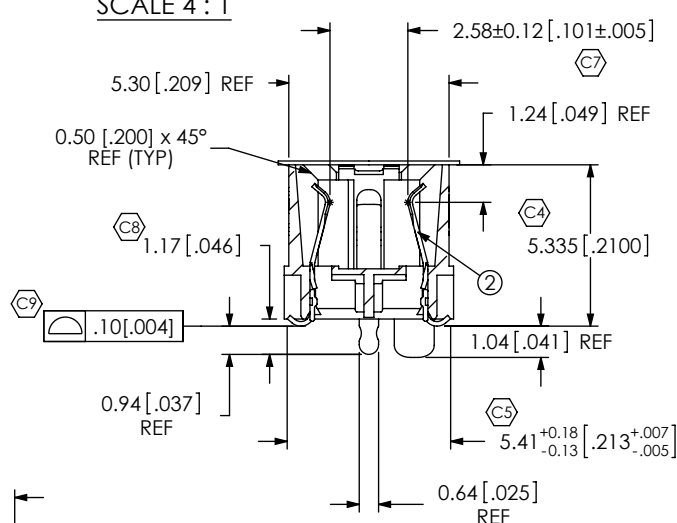
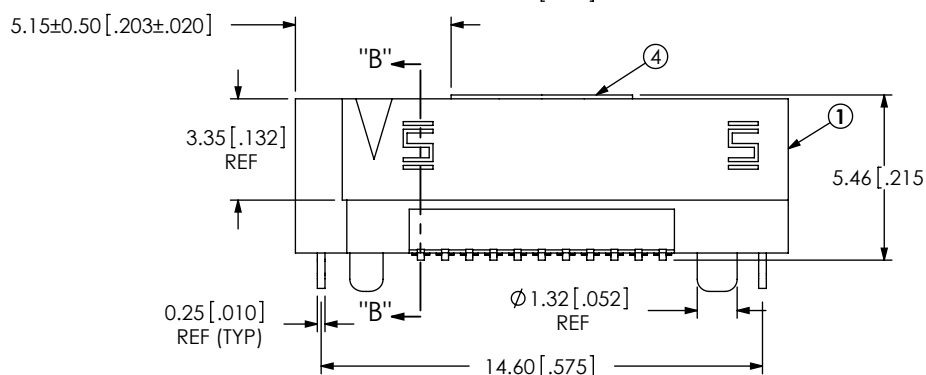
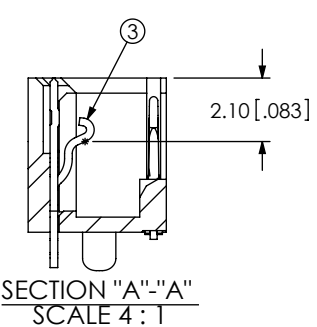
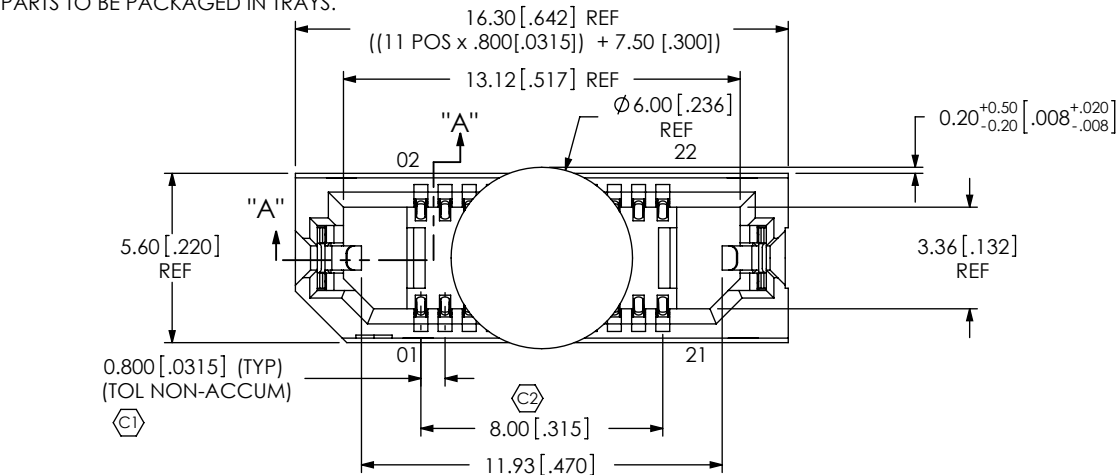

| ITEM NO. | PART NUMBER | QUANTITY | MATERIAL |
|----------|--------------------|----------|----------------------------|
| 1 | ERF8-011-05.0-DV-L | 1.0000 | VECTRA E130i, COLOR: BLACK |
| 2 | C-211-05.0-S | 22.000 | BeCu, 390 HT |
| 3 | WT-30-01-F | 2.0000 | BeCu, #25, 1/2 HT |
| 4 | K-500-300 | 1.0000 | POLYIMIDE FILM (KAPTON) |
| 5 | TY-ERF8049-11-5-L | 1.0000 | BLACK HIPS |

| | | |
|---|--|--|
| UNLESS OTHERWISE SPECIFIED, DIMENSIONS ARE IN MILLIMETERS. TOLERANCES ARE: DECIMALS ANGLES .X: ±.3[.01] 2° .XX: ±.13[.005] .XXX: ±.051[.0020] | PROPRIETARY NOTE THIS DOCUMENT CONTAINS INFORMATION CONFIDENTIAL AND PROPRIETARY TO SAMTEC, INC. AND SHALL NOT BE REPRODUCED OR TRANSFERRED TO OTHER DOCUMENTS OR DISCLOSED TO OTHERS OR USED FOR ANY PURPOSE OTHER THAN THAT WHICH IT WAS OBTAINED WITHOUT THE EXPRESSED WRITTEN CONSENT OF SAMTEC, INC. |  520 PARK EAST BLVD, NEW ALBANY, IN 47150 PHONE: 812-944-6733 FAX: 812-948-5047 e-Mail: info@SAMTEC.com code 53322 |
| | | |
| PLATING: CONTACT AREA: .000030 GOLD OVER .000050 NICKEL REMAINDER: .000200 REF TIN OVER .000050 NICKEL LATCHES: .000003 GOLD OVER .000050 NICKEL | | DWG. NO. ASP-137969-01 |
| C:\enterprise\vaull\dwg\sw\asp\137000\ASP-137969-01.SLDDRW | | BY: David F 01/24/2008 SHEET 1 OF 2 |

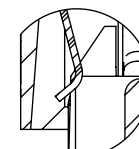
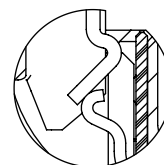
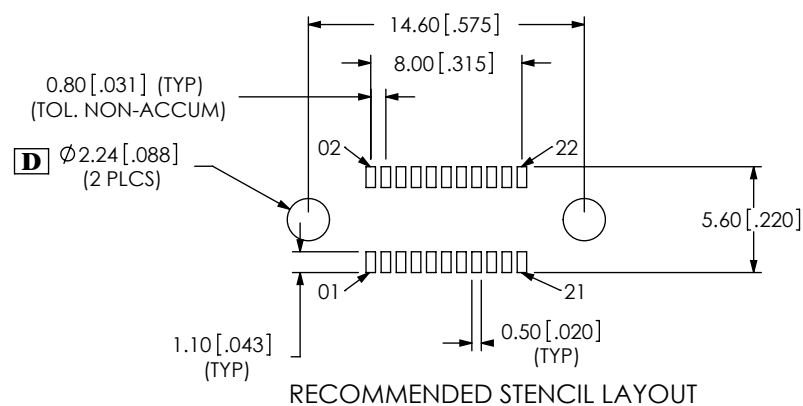
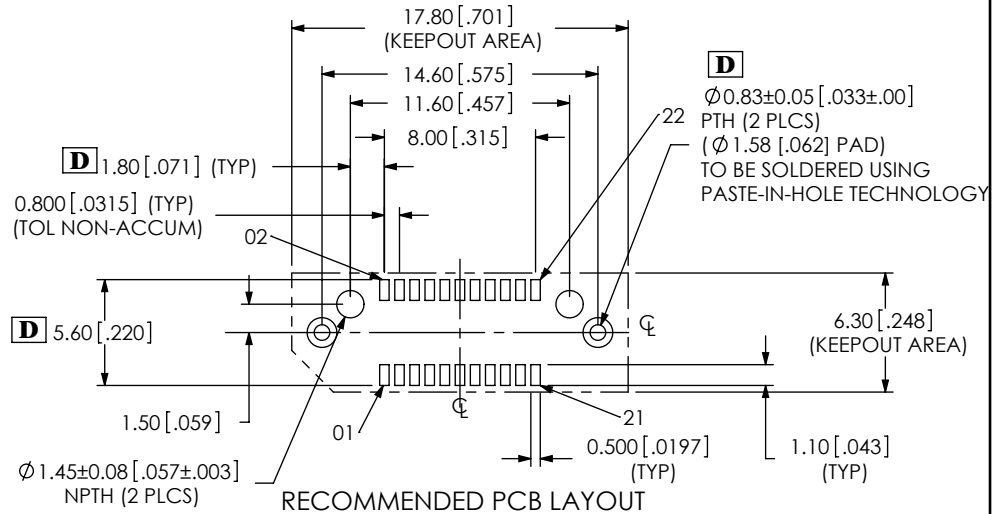
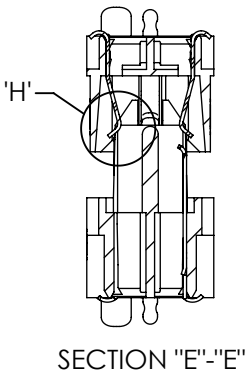
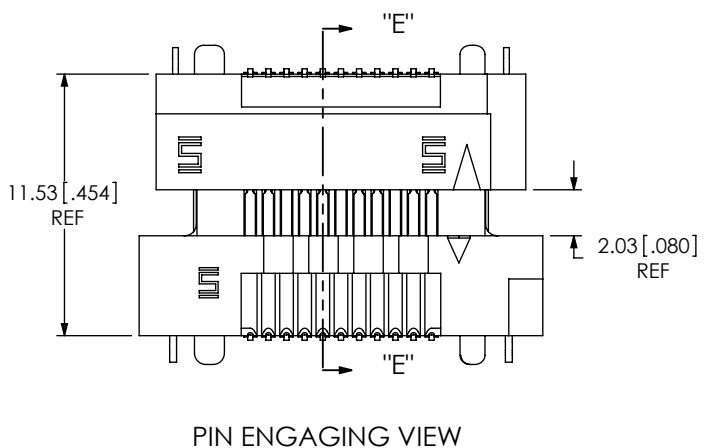
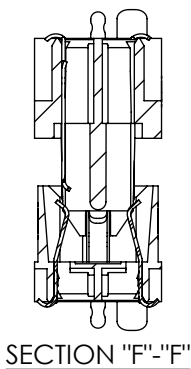
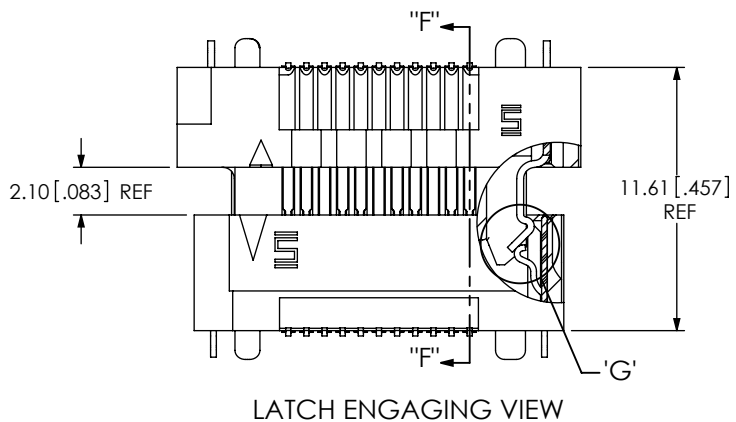

D
 $\varnothing 0.83 \pm 0.05$ [.033 ± .00]
 PTH (2 PLCS)
 ($\varnothing 1.58$ [.062] PAD)
 TO BE SOLDERED USING
 PASTE-IN-HOLE TECHNOLOGY

PROPRIETARY NOTE

THIS DOCUMENT CONTAINS INFORMATION CONFIDENTIAL AND PROPRIETARY TO SAMTEC, INC. AND SHALL NOT BE REPRODUCED OR TRANSFERRED TO OTHER DOCUMENTS OR DISCLOSED TO OTHERS OR USED FOR ANY PURPOSE OTHER THAN THAT WHICH IT WAS OBTAINED WITHOUT THE EXPRESSED WRITTEN CONSENT OF SAMTEC, INC.



520 PARK EAST BLVD, NEW ALBANY, IN 47150
 PHONE: 812-944-6733 FAX: 812-948-5047
 e-Mail: info@SAMTEC.com code 53322

SHEET SCALE: 3:1

DESCRIPTION: MODIFIED ERF8 ASSEMBLY

DWG. NO. ASP-137969-01

By: David F 01/24/2008 SHEET 2 OF 2