

DO NOT SCALE FROM THIS PRINT

- NOTES:
 1. VITA 57 CONNECTOR.
 2. $\text{\textcircled{2}}$ REPRESENTS A CRITICAL DIMENSION.
 3. MINIMUM PUSHOUT FORCE: 0.50 LBS.
 4. PARTS TO BE PACKAGED IN TAPE AND REEL.
 5. NOTE DELETED.
 6. DIMENSION C10 MUST BE MEASURED USING INSPECTION FIXTURE AT-1817-836-2, USE CO-AU-WI-2003-M FOR PROCESS.
 7. ATTACH LABEL "SEAX-0001" TO EACH TAPE & REEL PACKAGE.
 8. $\text{\textcircled{C}}$ MAXIMUM ROW TO ROW VARIATION .003[0.08], MEASURED FIRST & LAST POSITIONS ONLY, ALL ROWS

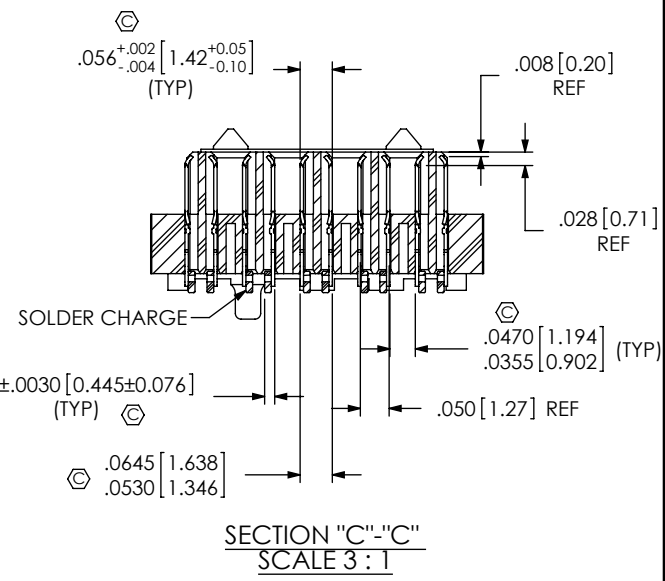
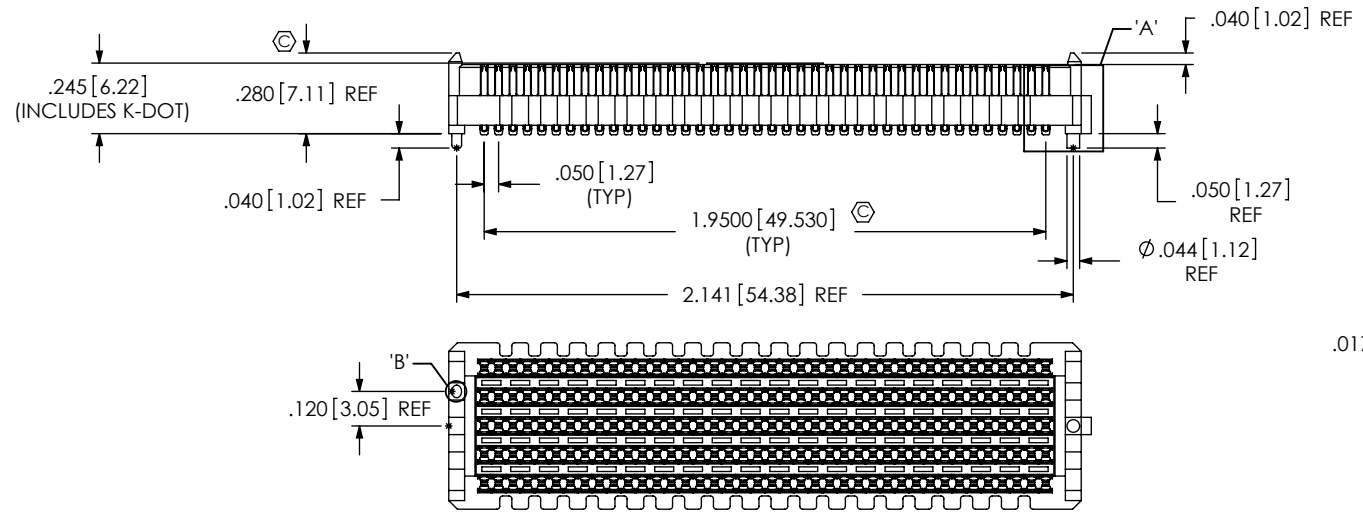
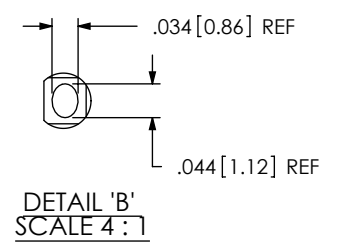
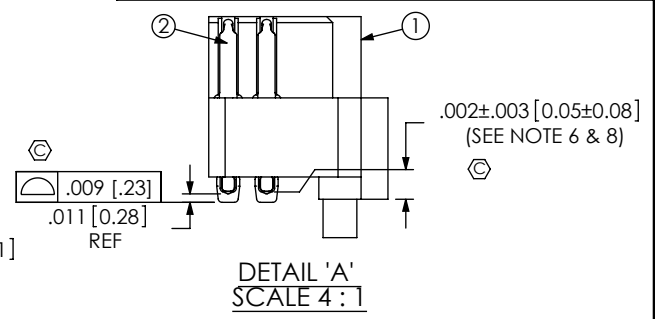
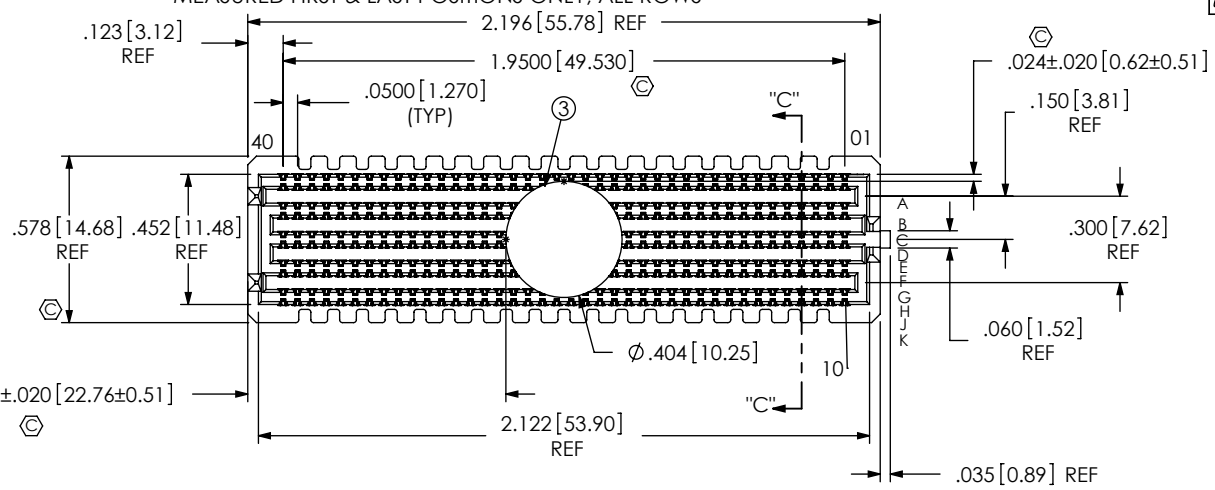

ITEM NO.	PART NUMBER	QUANTITY	MATERIAL
1	SEAM-40-03.5-10-A	1.0000	LCP, UL 94 V0, COLOR: BLACK
2	NEW-SUB-T-1M36-03.5-S-2	400.00	COPPER ALLOY / LEAD FREE SOLDER
3	K-DOT-.404-.500-.005	1.0000	POLYIMIDE FILM
4	CT-SEAM033MS	1.0000	CONDUCTIVE POLYMER

UNLESS OTHERWISE SPECIFIED, DIMENSIONS ARE IN INCHES. TOLERANCES ARE:
 DECIMALS ANGLES
 .XX: ±.01 [.3] 2°
 .XXX: ±.005 [.13]
 .XXXX: ±.0020 [.051]

PROPRIETARY NOTE
 THIS DOCUMENT CONTAINS INFORMATION CONFIDENTIAL AND PROPRIETARY TO SAMTEC, INC. AND SHALL NOT BE REPRODUCED OR TRANSFERRED TO OTHER DOCUMENTS OR DISCLOSED TO OTHERS OR USED FOR ANY PURPOSE OTHER THAN THAT WHICH IT WAS OBTAINED WITHOUT THE EXPRESSED WRITTEN CONSENT OF SAMTEC, INC.

DO NOT SCALE DRAWING SHEET SCALE: 1.5:1

PLATING:
 CONTACT AREA: .000030 GOLD OVER .000050 NICKEL
 REMAINDER: .000200 REF TIN OVER .000050 NICKEL

F:\DWG\MISC\MKTG\ASP-134488-01-MKT.SLDDRW

520 PARK EAST BLVD. NEW ALBANY, IN 47150
 PHONE: 812-944-6733 FAX: 812-948-5047
 e-Mail: info@SAMTEC.com code 55322

DESCRIPTION:
 .050 PITCH TERMINAL ARRAY ASSEMBLY

DWG. NO. ASP-134488-01

BY: G. PURVIS 11/02/2007 SHEET 1 OF 4

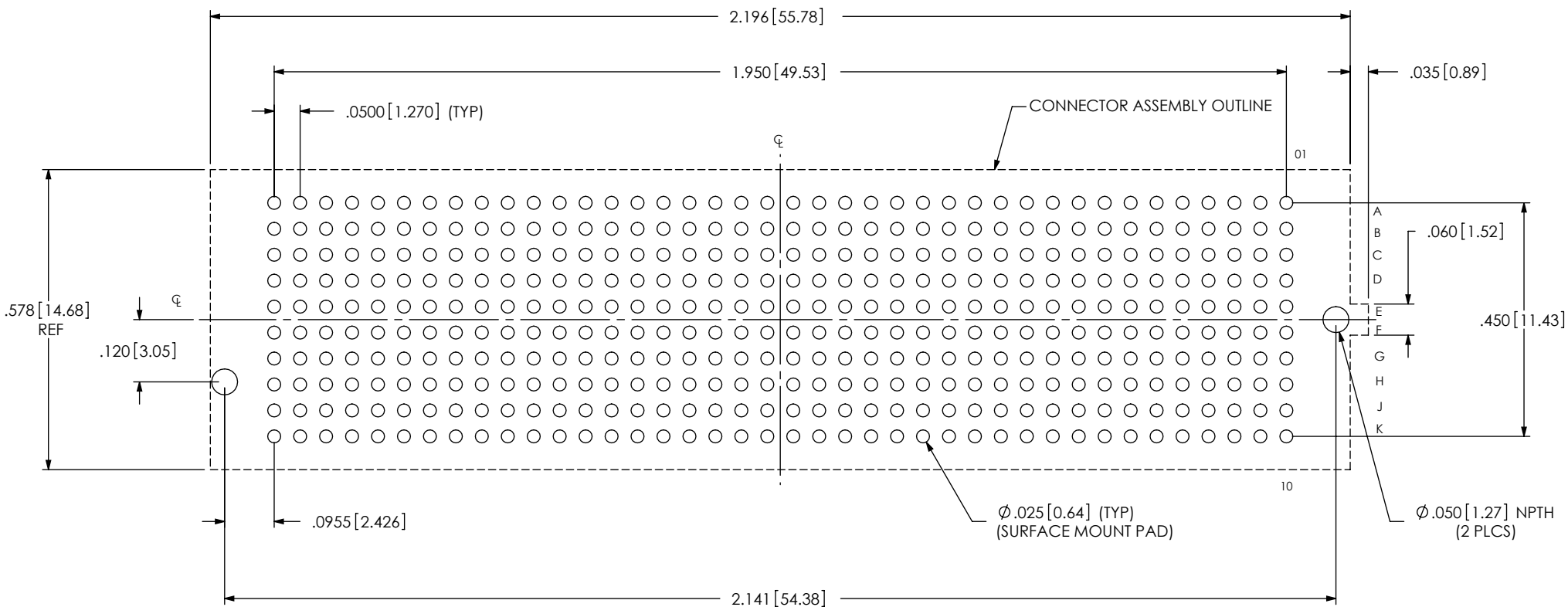

ALL DIMENSIONS ARE SYMMETRIC ABOUT THE CENTERLINE.

PROPRIETARY NOTE
 THIS DOCUMENT CONTAINS INFORMATION
 CONFIDENTIAL AND PROPRIETARY TO
 SAMTEC, INC. AND SHALL NOT BE REPRODUCED
 OR TRANSFERRED TO OTHER DOCUMENTS OR
 DISCLOSED TO OTHERS OR USED FOR ANY
 PURPOSE OTHER THAN THAT WHICH IT WAS
 OBTAINED WITHOUT THE EXPRESSED WRITTEN
 CONSENT OF SAMTEC, INC.



520 PARK EAST BLVD, NEW ALBANY, IN 47150
 PHONE: 812-944-6733 FAX: 812-948-5047
 e-Mail info@SAMTEC.com code 55322

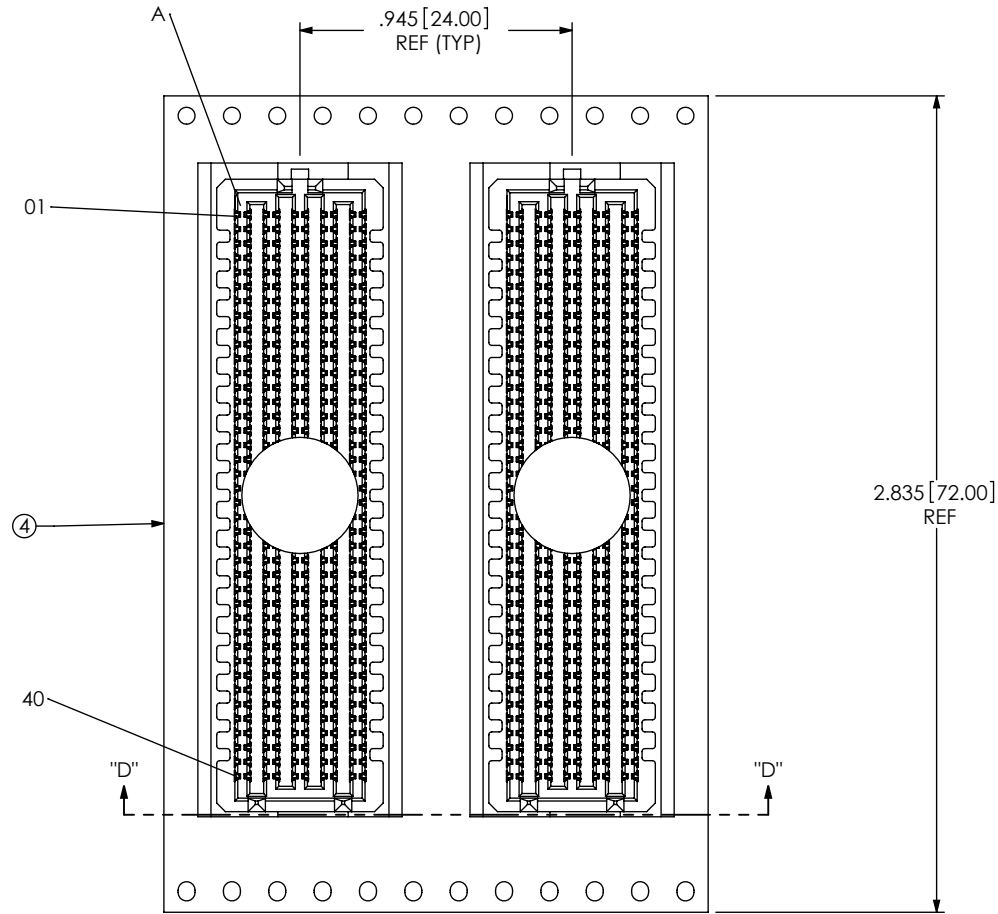

USER DIRECTION OF UN-REELING →
POCKET NOT DETAILED

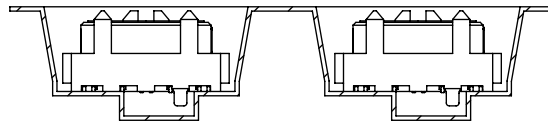

SECTION "D"-"D"
PACKAGING VIEW

PROPRIETARY NOTE

THIS DOCUMENT CONTAINS INFORMATION CONFIDENTIAL AND PROPRIETARY TO SAMTEC, INC. AND SHALL NOT BE REPRODUCED OR TRANSFERRED TO OTHER DOCUMENTS OR DISCLOSED TO OTHERS OR USED FOR ANY PURPOSE OTHER THAN THAT WHICH IT WAS OBTAINED WITHOUT THE EXPRESSED WRITTEN CONSENT OF SAMTEC, INC.



520 PARK EAST BLVD., NEW ALBANY, IN 47150
PHONE: 812-944-6733 FAX: 812-948-5047
e-Mail info@SAMTEC.com code 55322

SHEET SCALE: 1.5:1

DESCRIPTION:
.050 PITCH TERMINAL ARRAY ASSEMBLY

DWG. NO. ASP-134488-01