

General Description

The ADT7200 is system specific power IC that is suitable for black and white CCD camera. Other features include over-current protection and thermal shutdown. It reduces design complexity and external component count.



Features

- Input voltage range : 9.6V to 14V
- 2 CH regulated 5V output
- Regulated 15V charge pump output
- Regulated -7V charge pump output
- Power-on-reset output
- Thermal shutdown
- Over-current protection
- Under voltage lock out
- Small size (5 x 5 mm² body) and thermally enhanced 20 pin MLF package

Applications

- Black and white CCD camera
- CCTV camera
- 5V / -7V / 15V distributed power system

Typical Application Circuit

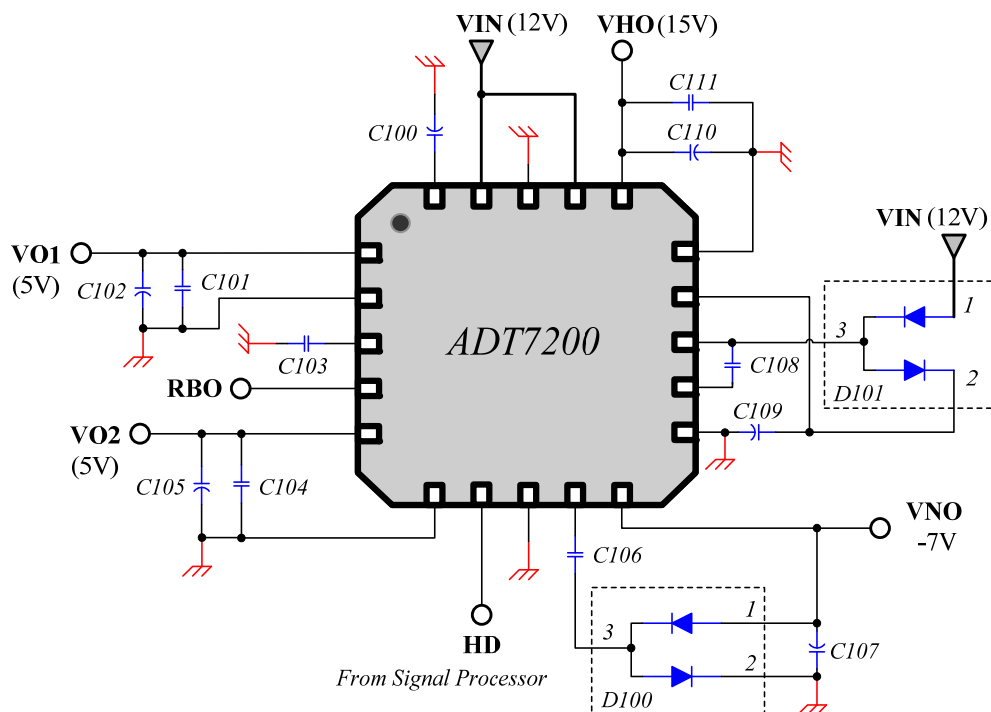

* This specifications are subject to be changed without notice

Part List

Component	Description	Type	Value
D100	Two schottky diode integrated	IC	BAT54SWT1
D101	Two schottky diode integrated	IC	BAT54SWT1
C100	Bypass capacitor	TANTALUM CAPACITOR	10uF/20V
C110	Load capacitor for VHO	TANTALUM CAPACITOR	10uF/20V
C102	Load capacitor for VO1	TANTALUM CAPACITOR	10uF/10V
C105	Load capacitor for VO2	TANTALUM CAPACITOR	10uF/10V
C109	Load capacitor for Doubler	TANTALUM CAPACITOR	1uF/35V
C107	Load capacitor for Inverter	TANTALUM CAPACITOR	10uF/10V
C106	Flying capacitor for Inverter	MLCC	4.7uF/25V
C108	Flying capacitor for Doubler	MLCC	4.7uF/25V
C111	Load capacitor for VHO	MLCC	0.1uF/20V
C101	Load capacitor for VO1	MLCC	0.1uF/20V
C104	Load capacitor for VO2	MLCC	0.1uF/20V
C103	Delay time control capacitor for RBO signal	MLCC	10nF/10V

Pin Configuration

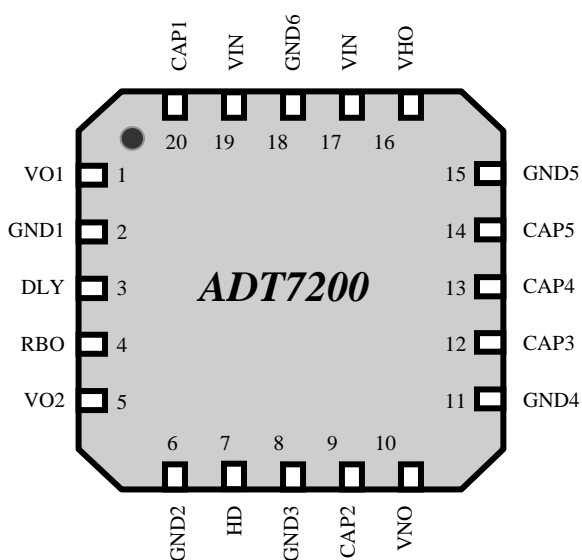

* This specifications are subject to be changed without notice

Pin Description

Pin No.	Name	I/O	Type	Description
1	VO1	O	A	Voltage output for +5V digital application
2	GND1	-	G	Ground
3	DLY	IO	A	Power-on reset delay capacitor terminal
4	RBO	O	D	Power-on reset output
5	VO2	O	A	Voltage output for +5V analog application
6	GND2	-	G	Ground
7	HD	I	D	Horizontal Drive signal input
8	GND3	-	G	Ground
9	CAP2	IO	D	Positive flying capacitor terminal for inverter operation
10	VNO	O	A	-7V output for CCD
11	GND4	-	G	Ground
12	CAP3	IO	D	Negative flying capacitor terminal for doubler operation
13	CAP4	IO	D	Positive flying capacitor terminal for doubler operation
14	CAP5	IO	A	Positive load capacitor terminal for doubler operation
15	GND5	-	G	Ground
16	VHO	O	A	+15V output for CCD
17	VIN	-	P	Power supply
18	GND6	-	G	Ground
19	VIN	-	P	Power supply
20	CAP1	O	A	By-pass capacitor(+)

Note : In typical application, Pin 17 and Pin 19 are connected externally.

I : Input pin O : Output pin IO : Input/Output pin
 P : Power pin G : Ground pin
 A : Analog pin D : Digital pin

** This specifications are subject to be changed without notice*

Functional Block Diagram

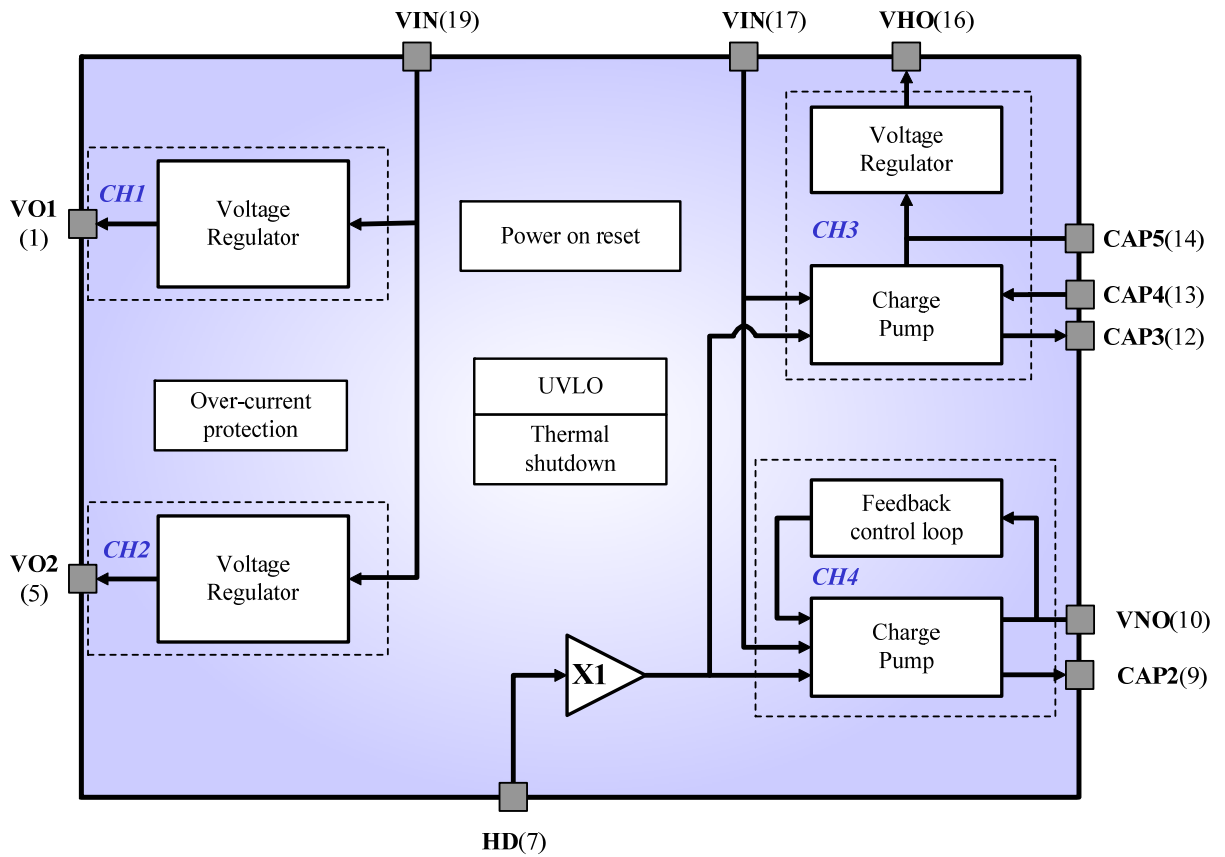

Absolute Maximum Ratings

Parameter	Symbol	Min.	Typ.	Max.	Unit
Power supply voltage	V_{IN}	-	-	17	V
Power dissipation ($T_a=70^\circ\text{C}$) (Note1)	P_{Dmax}	-	-	2.25	W
Storage temperature	T_{STG}	-65	-	+150	$^\circ\text{C}$
Junction temperature	T_{Jmax}	-	-	+150	$^\circ\text{C}$
Thermal resistance	Θ_{JA}	-	35	-	$^\circ\text{C}/\text{W}$

Note1. derate $35^\circ\text{C}/\text{W}$ above $+70^\circ\text{C}$.

Stresses beyond those listed under "Absolute Maximum Ratings" may cause permanent damage to the device. These are stress ratings only, and functional operation of the device at these or any other conditions beyond those indicated in the operational sections of the specifications is not implied. Exposure to absolute maximum rating conditions for extended periods may affect device reliability.

* This specifications are subject to be changed without notice

Operating Ratings (Ta=25°C)

Parameter	Symbol	Min	Typ.	Max.	Unit
Power supply voltage	V _{IN}	9.6	12.0	14.0	V
Operating temperature	T _{OPR}	-40	-	+85	°C
Junction temperature	T _J	-40	-	+125	°C
Max. power dissipation (Ta=70°C)*1	P _D	-	0.65	1.5	W

*1 This spec. indicates that junction temperature of the device is under 125°C. In specific applications, this is recommended under this power dissipation specification.

Electrical Characteristics (Ta=25°C, V_{IN}=12V, unless otherwise noted)

Parameter	Condition	Min	Typ	Max	Unit	Note	
Operating supply voltage	-	9.6	12	14	V		
Quiescent current at operation	V _{IN} =12V, w/o loading	-	17	25	mA		
Power on reset	Tdelay	C103 = 10nF	0.5	1.0	1.5	msec	
	VOH	-	4.75	5.0	5.25	V	
Channel 1 (+5V Digital)							
Output voltage	I _O =50mA	4.75	5.0	5.25	V		
Output drive current	-	70	-	-	mA		
Channel 2 (+5V Analog)							
Output voltage	I _O =30mA	4.75	5.0	5.25	V		
Output drive current	-	70	-	-	mA		
Channel 3 (+15V CCD)							
Output voltage	I _O =8mA	14.55	15	15.45	V		
Output drive current	-	10	-	-	mA		
Channel 4 (-7V CCD)							
Output voltage	I _O =-2mA	-7.5	-7	-6.5	V		
Output drive current	-	-	-	-5	mA		

- HD signal description
 period = 63.6usec, duty = 90%, 5Vp.p

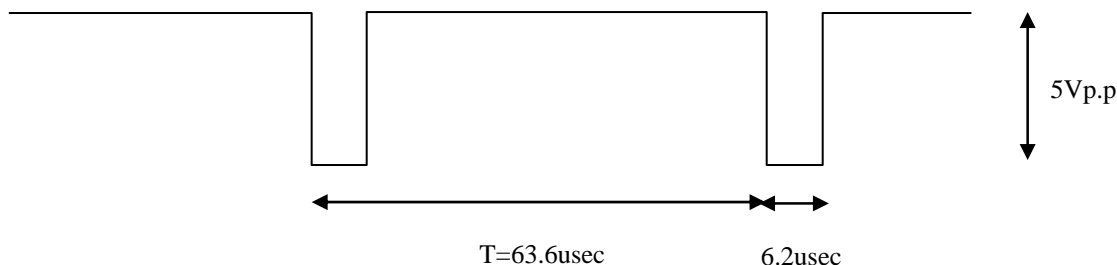

* This specifications are subject to be changed without notice

Package ; 20MLF, 5mm x 5mm body (units : mm)

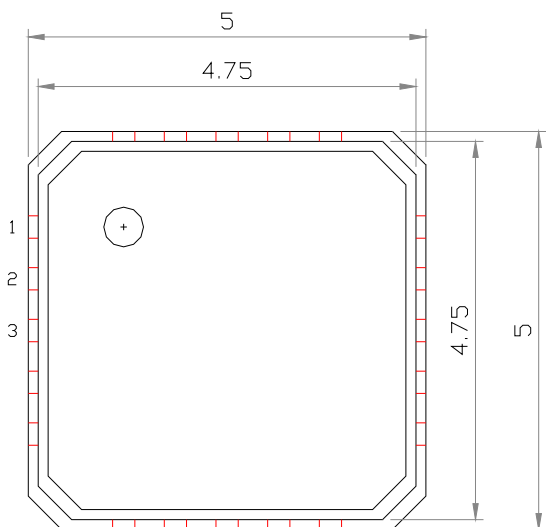

TOP VIEW

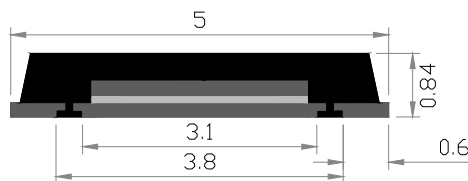

SIDE VIEW

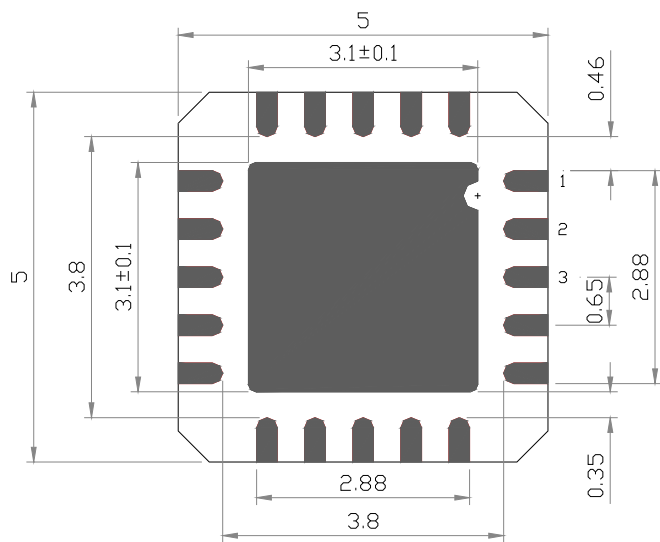

BOTTOM VIEW

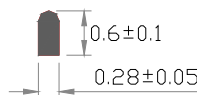

* This specifications are subject to be changed without notice