

**Pin Definition:**

1. Gate
2. Drain
3. Source

**PRODUCT SUMMARY**

$V_{DS}$ (V)	$R_{DS(on)}$ ( $\Omega$ )	$I_D$ (A)
900	5.1 @ $V_{GS}=10V$	1.5

**General Description**

The TSM3N90 N-Channel Power MOSFET is produced by new advance planar process. This advanced technology has been especially tailored to minimize on-state resistance, provide superior switching performance, and withstand high energy pulse in the avalanche and commutation mode.

**Features**

- Low  $R_{DS(ON)}$  4.3 $\Omega$  (Typ.)
- Low gate charge typical @ 17nC (Typ.)
- Low  $C_{rss}$  typical @ 8.7pF (Typ.)

**Ordering Information**

Part No.	Package	Packing
TSM3N90CH C5G	TO-251	75pcs / Tube
TSM3N90CP ROG	TO-252	2.5Kpcs / 13" Reel
TSM3N90CZ C0	TO-220	50pcs / Tube
TSM3N90CI C0	ITO-220	50pcs / Tube

**Note:** "G" denotes for Halogen Free

**Block Diagram**

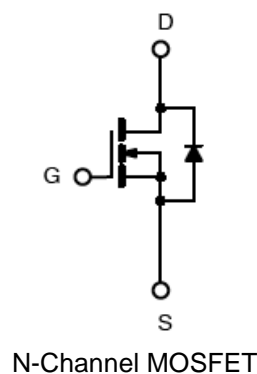

**Absolute Maximum Rating** ( $T_a = 25^\circ C$  unless otherwise noted)

Parameter	Symbol	Limit			Unit
		IPAK/DPAK	ITO-220	TO-220	
Drain-Source Voltage	$V_{DS}$	900			V
Gate-Source Voltage	$V_{GS}$	$\pm 30$			V
Continuous Drain Current	$I_D$	$T_C = 25^\circ C$			A
		$T_C = 100^\circ C$			A
Pulsed Drain Current *	$I_{DM}$	10			A
Single Pulse Avalanche Energy (Note 2)	$E_{AS}$	16.6			mJ
Avalanche Current (Repetitive) (Note 1)	$I_{AR}$	2.5			A
Repetitive Avalanche Energy (Note 1)	$E_{AR}$	9.4			mJ
Peak Diode Recovery dv/dt (Note 3)	dv/dt	4.5			V/ns
Total Power Dissipation @ $T_C = 25^\circ C$	$P_{TOT}$	94	32	94	W
Operating Junction Temperature	$T_J$	150			$^\circ C$
Storage Temperature Range	$T_{STG}$	-55 to +150			$^\circ C$

**Note:** Limited by maximum junction temperature

### Thermal Performance

Parameter	Symbol	IPAK/DPAK	ITO-220	TO-220	Unit
Thermal Resistance - Junction to Case	$R\theta_{JC}$	1.33	1.33	3.9	°C/W
Thermal Resistance - Junction to Ambient	$R\theta_{JA}$	110	62.5		

### Electrical Specifications (Ta = 25°C unless otherwise noted)

Parameter	Conditions	Symbol	Min	Typ	Max	Unit
<b>Static</b>						
Drain-Source Breakdown Voltage	$V_{GS} = 0V, I_D = 250\mu A$	$BV_{DSS}$	900	--	--	V
Drain-Source On-State Resistance	$V_{GS} = 10V, I_D = 1.25A$	$R_{DS(ON)}$	--	4.3	5.1	$\Omega$
Gate Threshold Voltage	$V_{DS} = V_{GS}, I_D = 250\mu A$	$V_{GS(TH)}$	2.0	--	4.0	V
Zero Gate Voltage Drain Current	$V_{DS} = 900V, V_{GS} = 0V$	$I_{DSS}$	--	--	10	$\mu A$
Gate Body Leakage	$V_{GS} = \pm 30V, V_{DS} = 0V$	$I_{GSS}$	--	--	$\pm 100$	nA
Forward Transfer Conductance	$V_{DS} = 30V, I_D = 1.25A$	$g_{fs}$	--	3	--	S
<b>Dynamic</b>						
Total Gate Charge	$V_{DS} = 720V, I_D = 2.5A,$ $V_{GS} = 10V$	$Q_g$	--	17	--	nC
Gate-Source Charge		$Q_{gs}$	--	2.4	--	
Gate-Drain Charge		$Q_{gd}$	--	6.6	--	
Input Capacitance	$V_{DS} = 25V, V_{GS} = 0V,$ $f = 1.0MHz$	$C_{iss}$	--	748	--	pF
Output Capacitance		$C_{oss}$	--	55	--	
Reverse Transfer Capacitance		$C_{rss}$	--	8.7	--	
<b>Switching</b>						
Turn-On Delay Time	$V_{GS} = 10V, I_D = 2.5A,$ $V_{DD} = 450V, R_G = 25\Omega$	$t_{d(on)}$	--	16	--	nS
Turn-On Rise Time		$t_r$	--	25	--	
Turn-Off Delay Time		$t_{d(off)}$	--	63	--	
Turn-Off Fall Time		$t_f$	--	31	--	
<b>Source-Drain Diode Ratings and Characteristic</b>						
Source Current	Integral reverse diode in the MOSFET	$I_S$	--	--	2.5	A
Source Current (Pulse)		$I_{SM}$	--	--	10	A
Diode Forward Voltage	$I_S = 2.5A, V_{GS} = 0V$	$V_{SD}$	--	--	1.5	V
Reverse Recovery Time	$V_{GS} = 0V, I_S = 2.5A,$	$t_{fr}$	--	355	--	nS
Reverse Recovery Charge	$dI_F/dt = 100A/\mu s$	$Q_{fr}$	--	1.8	--	$\mu C$

**Note 1:** Repetitive Rating: Pulse Width Limited by Maximum Junction Temperature

**Note 2:**  $V_{DD} = 50V, I_{AS} = 2.5A, L = 5mH, R_G = 25\Omega$ , Starting  $T_J = 25^\circ C$

**Note 3:**  $I_{SD} \leq 2.5A, di/dt \leq 200A/\mu s, V_{DD} \leq BV_{DSS}$ , Starting  $T_J = 25^\circ C$

**Note 4:** Pulse test: pulse width  $\leq 300\mu s$ , duty cycle  $\leq 2\%$

**Note 5:** Essentially Independent of Operating Temperature

### Gate Charge Test Circuit & Waveform

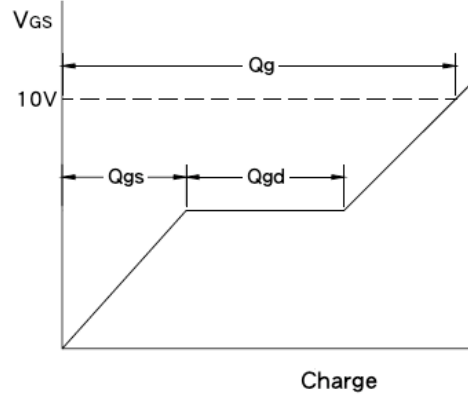
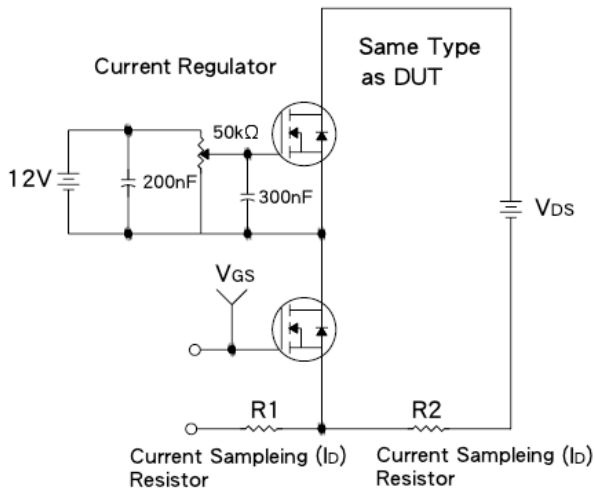

### Resistive Switching Test Circuit & Waveform

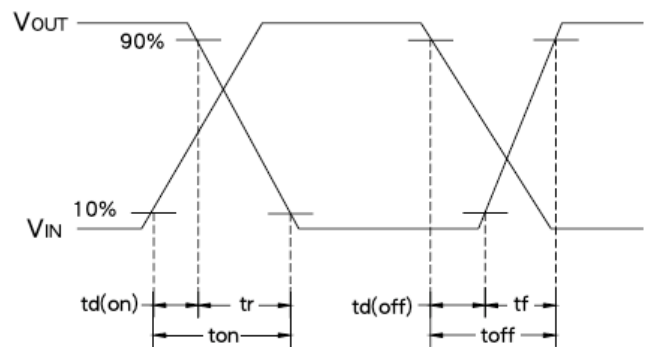
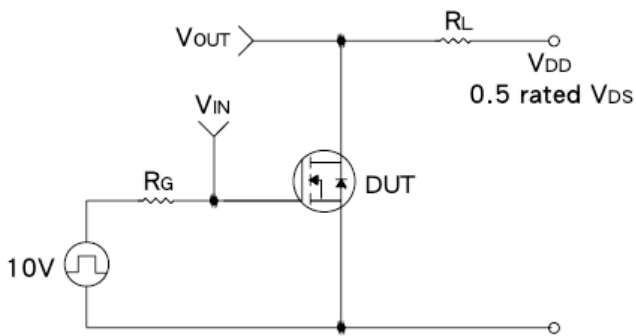

### E<sub>AS</sub> Test Circuit & Waveform

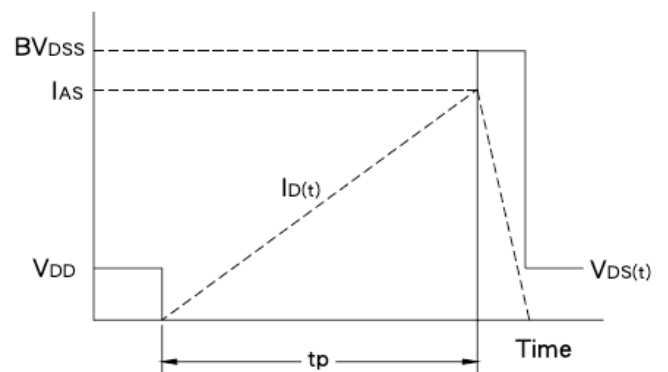
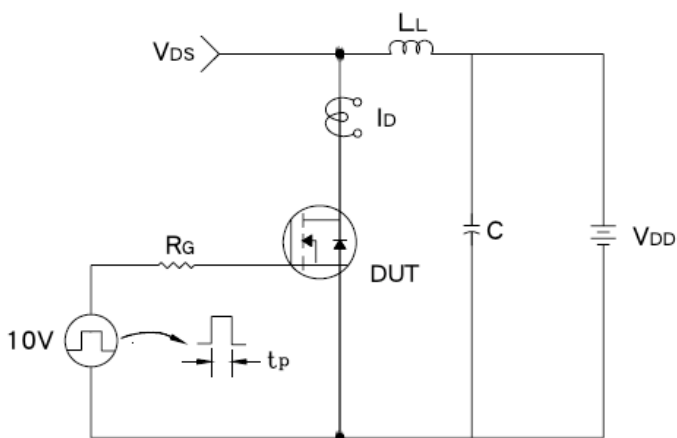

**Diode Reverse Recovery Time Test Circuit & Waveform**

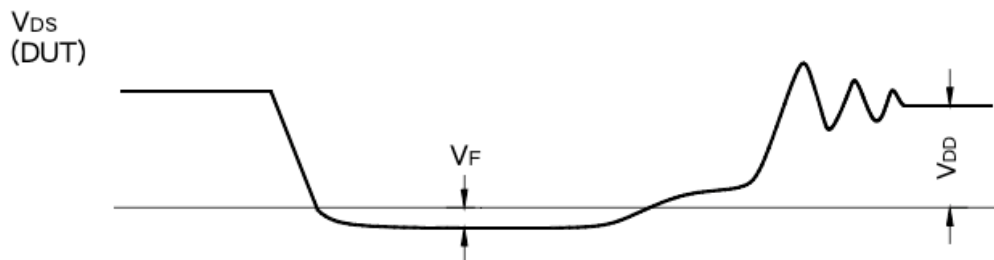
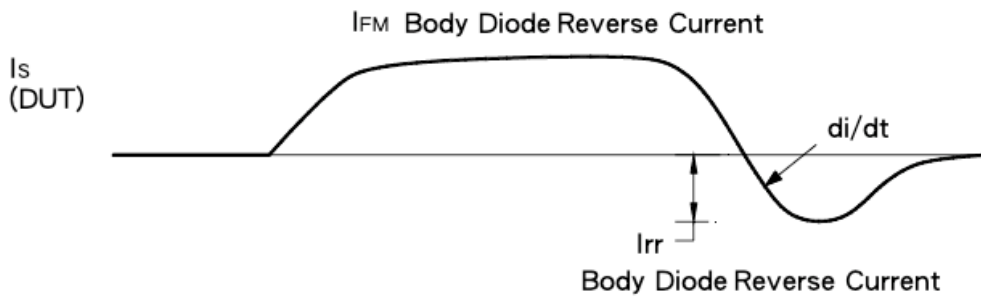
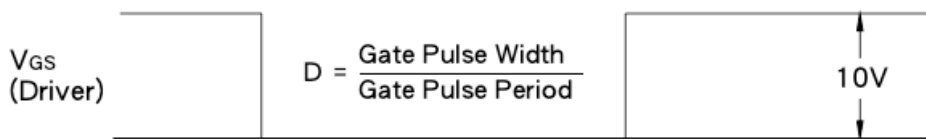
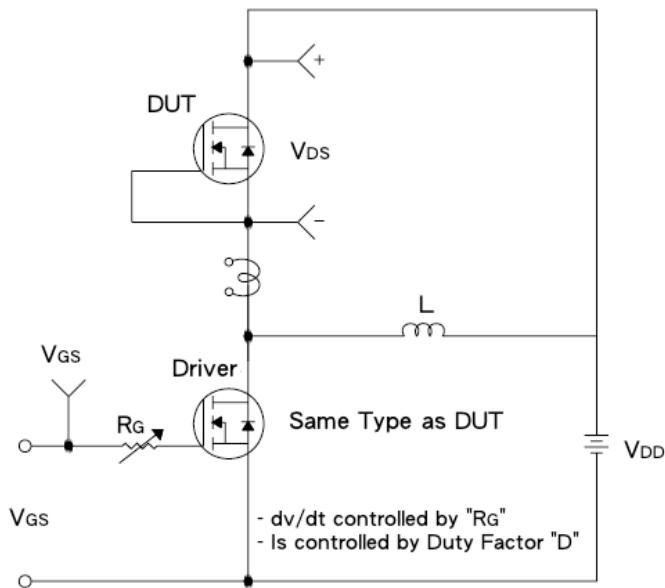

**Electrical Characteristics Curve** ( $T_c = 25^\circ\text{C}$ , unless otherwise noted)

**Output Characteristics**

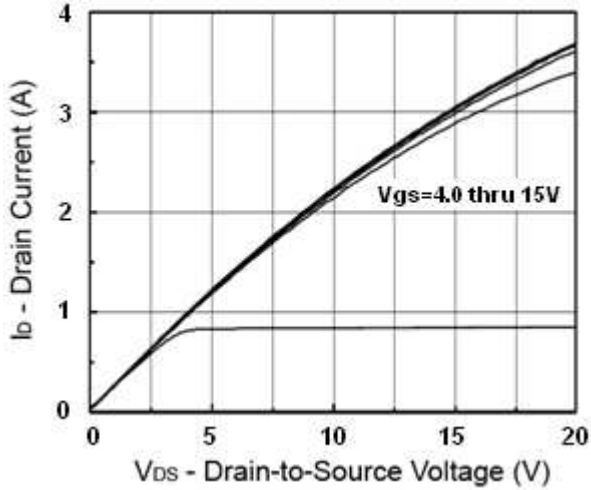

**Transfer Characteristics**

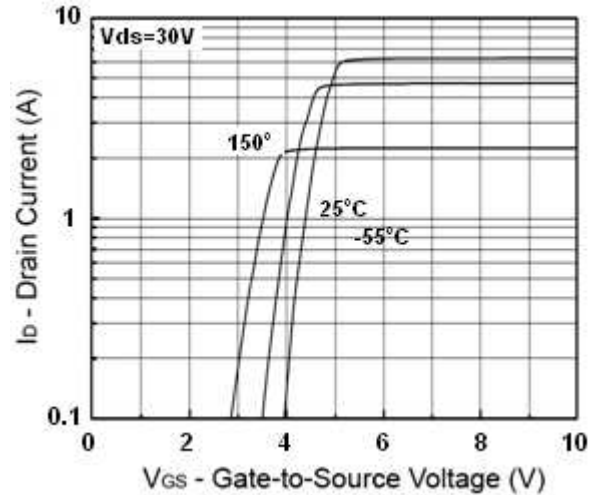

**On-Resistance vs. Drain Current**

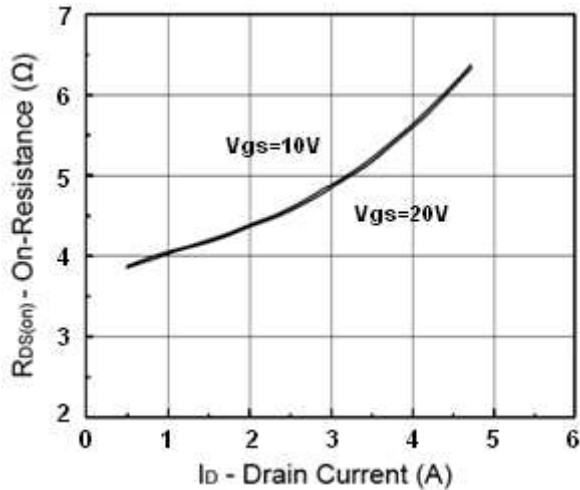

**Gate Charge**

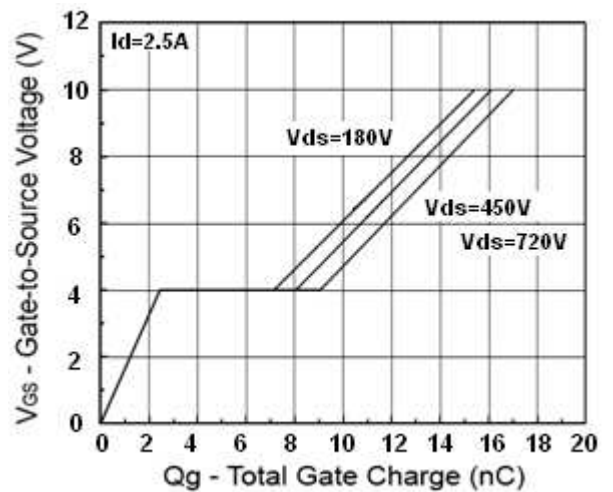

**On-Resistance vs. Junction Temperature**

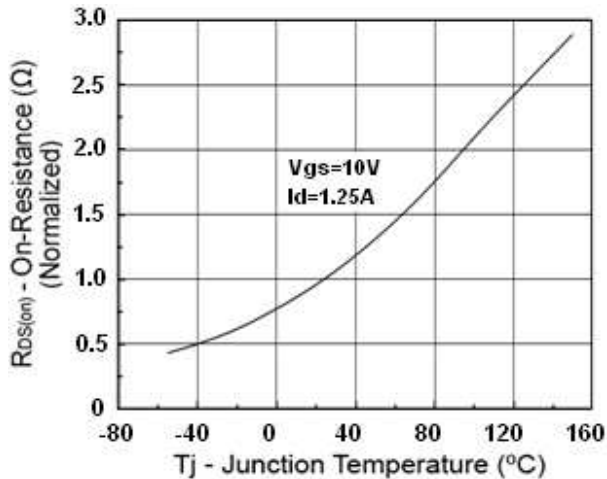

**Source-Drain Diode Forward Voltage**

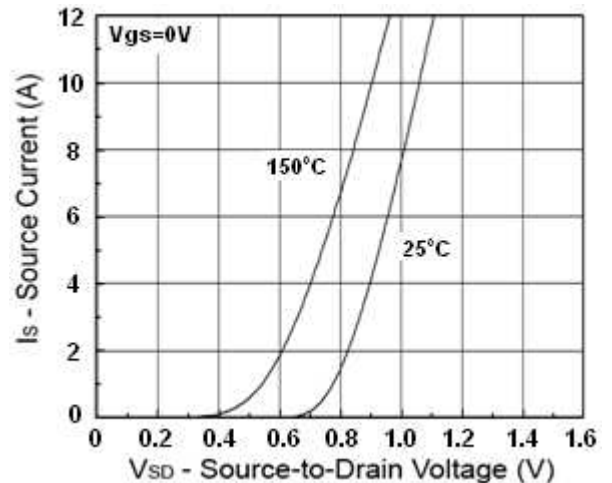

**Electrical Characteristics Curve** ( $T_a = 25^\circ\text{C}$ , unless otherwise noted)

**Drain Current vs. Case Temperature**

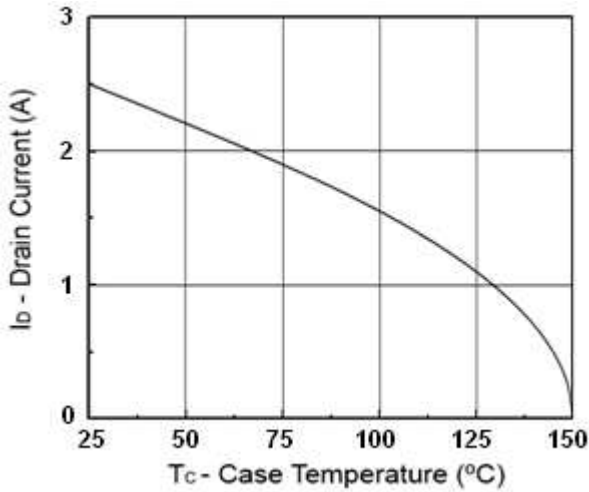

**$BV_{DSS}$  vs. Junction Temperature**

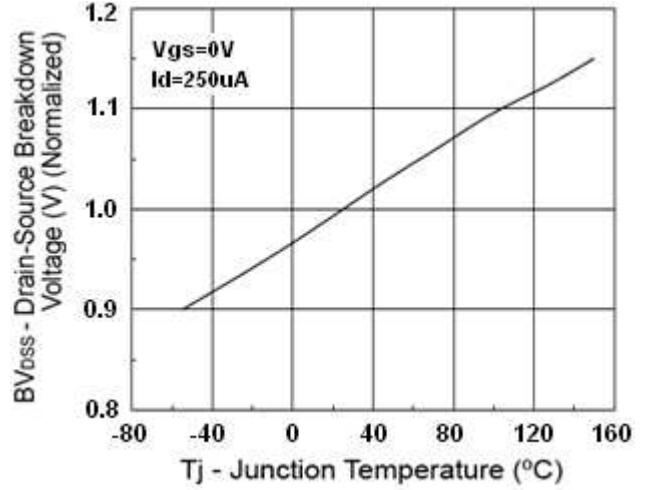

**Maximum Safe Operating Area**

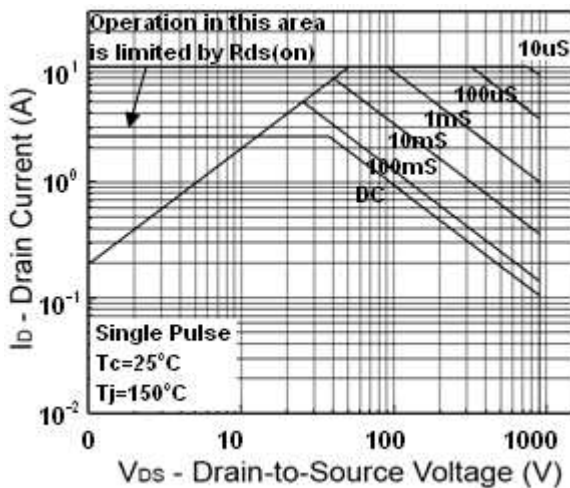

**Capacitance vs. Drain-Source Voltage**

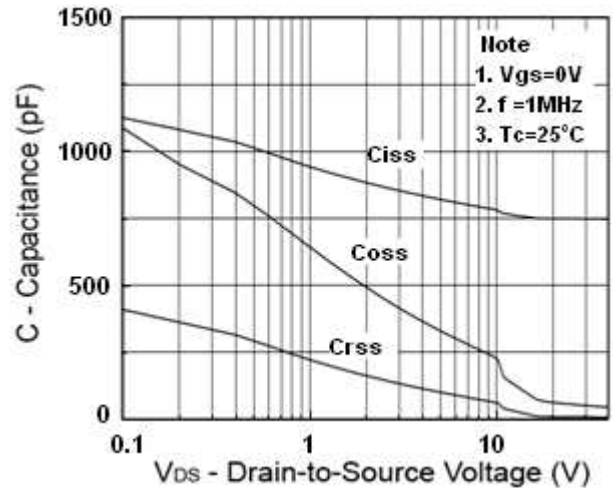

**Maximum Safe Operating Area (ITO-220)**

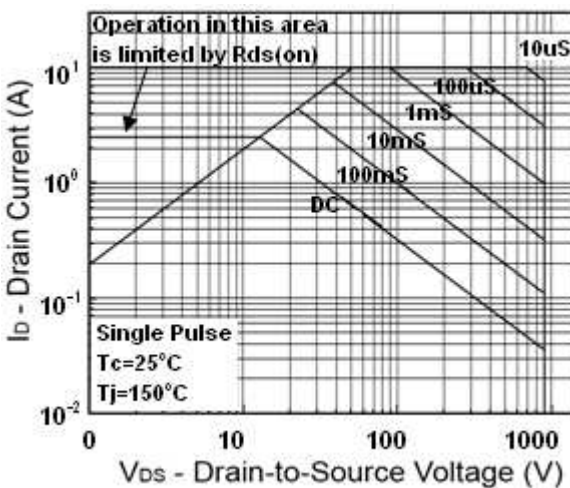



**Electrical Characteristics Curve** ( $T_a = 25^{\circ}\text{C}$ , unless otherwise noted)

**Normalized Thermal Transient Impedance, Junction-to-Ambient**

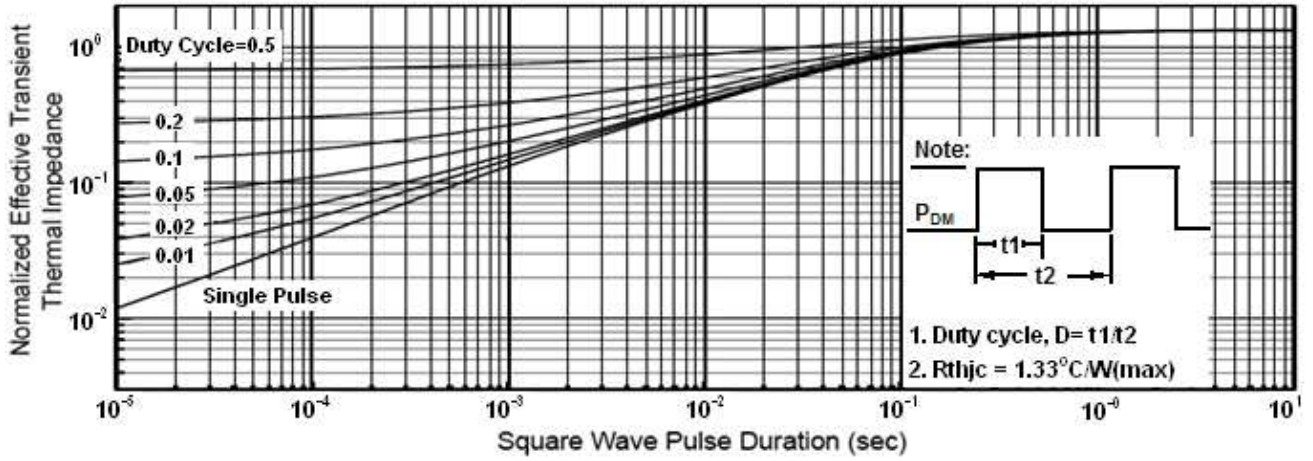

**Normalized Thermal Transient Impedance, Junction-to-Ambient (ITO-220)**

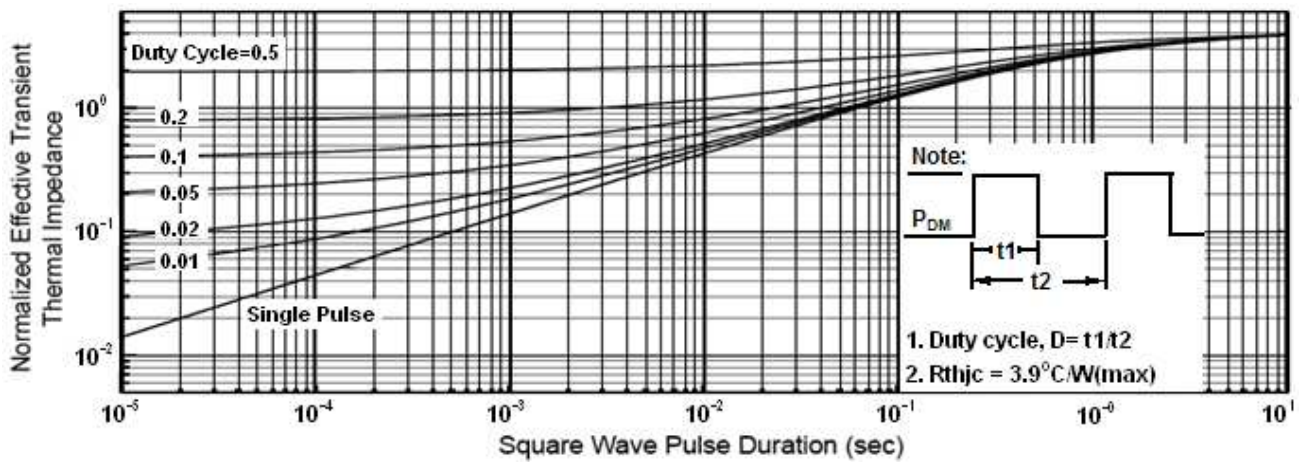

**TO-220 Mechanical Drawing**

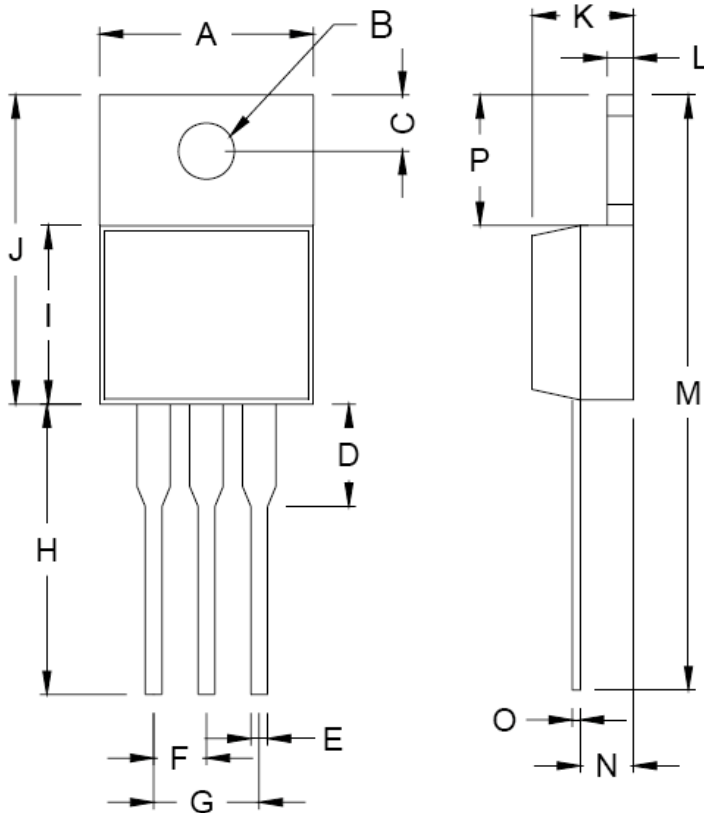

DIM	TO-220 DIMENSION			
	MILLIMETERS		INCHES	
	MIN	MAX	MIN	MAX
A	10.00	10.50	0.394	0.413
B	3.74	3.91	0.147	0.154
C	2.44	2.94	0.096	0.116
D	--	6.35	--	0.250
E	0.38	1.10	0.015	0.043
F	2.34	2.71	0.092	0.107
G	4.69	5.43	0.185	0.214
H	12.70	14.73	0.500	0.580
J	8.38	9.38	0.330	0.369
K	14.22	16.51	0.560	0.650
L	3.55	4.82	0.140	0.190
M	1.16	1.40	0.046	0.055
N	27.70	29.62	1.091	1.166
O	2.03	2.92	0.080	0.115
P	0.25	0.61	0.010	0.024



### ITO-220 Mechanical Drawing

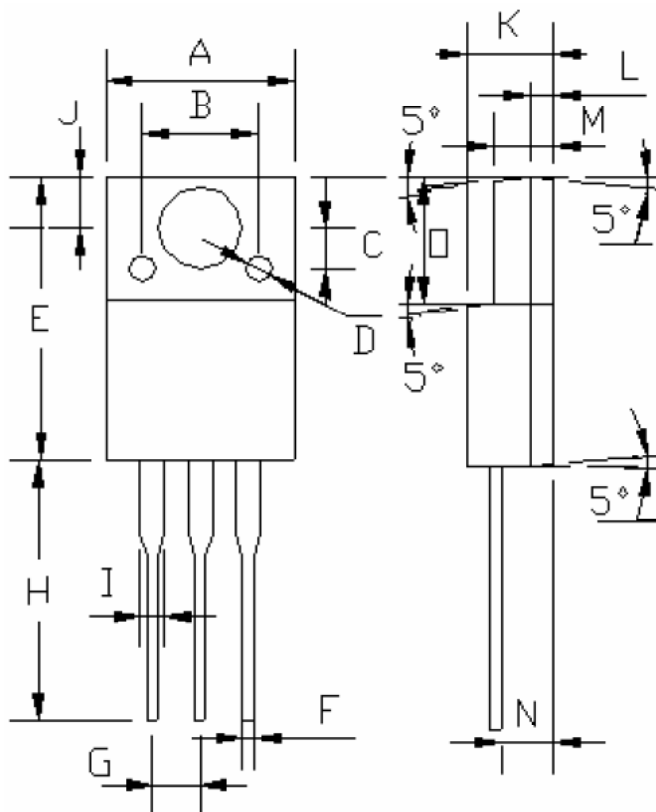

ITO-220 DIMENSION				
DIM	MILLIMETERS		INCHES	
	MIN	MAX	MIN	MAX
A	10.04	10.07	0.395	0.396
B	6.20 (typ.)		0.244 (typ.)	
C	2.20 (typ.)		0.087 (typ.)	
D	§ 1.40 (typ.)		§ 0.055 (typ.)	
E	15.0	15.20	0.591	0.598
F	0.52	0.54	0.020	0.021
G	2.35	2.73	0.093	0.107
H	13.50	13.55	0.531	0.533
I	1.11	1.49	0.044	0.058
J	2.60	2.80	0.102	0.110
K	4.49	4.50	0.176	0.177
L	1.15 (typ.)		0.045 (typ.)	
M	3.03	3.05	0.119	0.120
N	2.60	2.80	0.102	0.110
O	6.55	6.65	0.258	0.262

### TO-251 Mechanical Drawing

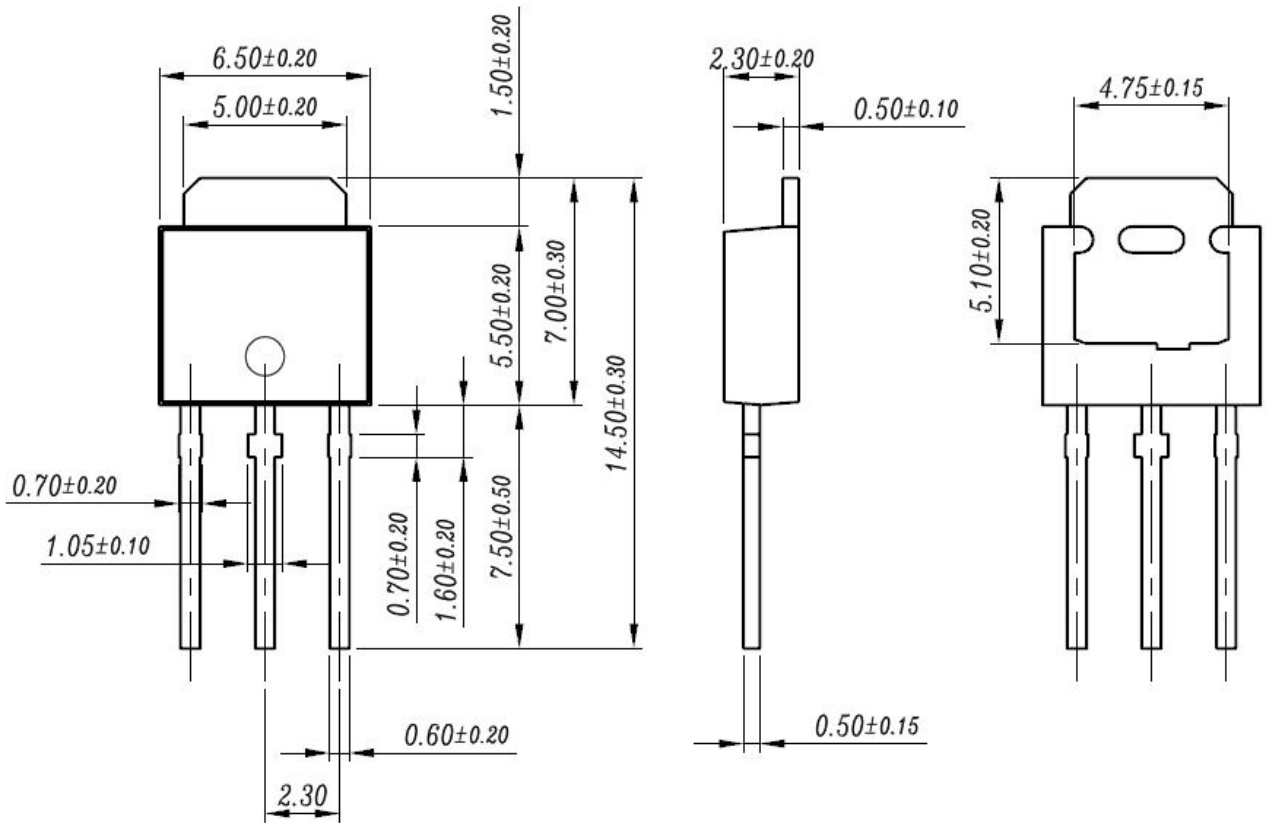

### TO-252 Mechanical Drawing

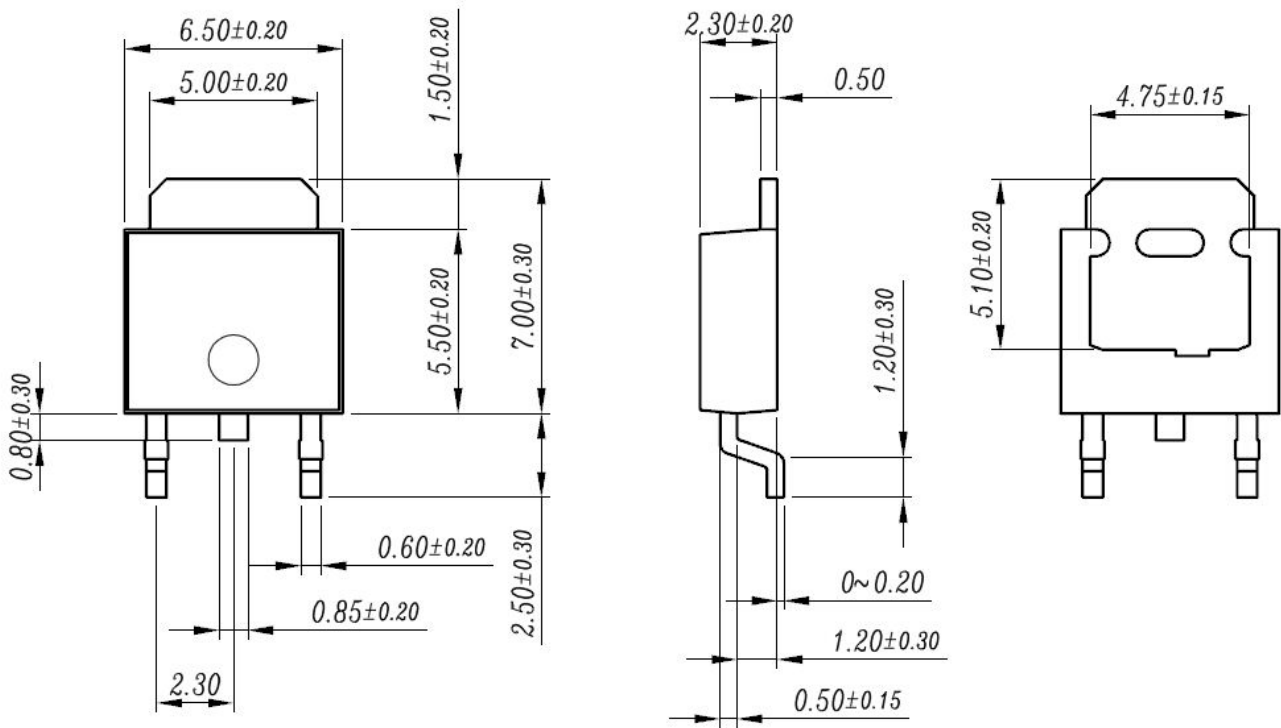

Unit: Millimeters

### Notice

Specifications of the products displayed herein are subject to change without notice. TSC or anyone on its behalf, assumes no responsibility or liability for any errors or inaccuracies.

Information contained herein is intended to provide a product description only. No license, express or implied, to any intellectual property rights is granted by this document. Except as provided in TSC's terms and conditions of sale for such products, TSC assumes no liability whatsoever, and disclaims any express or implied warranty, relating to sale and/or use of TSC products including liability or warranties relating to fitness for a particular purpose, merchantability, or infringement of any patent, copyright, or other intellectual property right.

The products shown herein are not designed for use in medical, life-saving, or life-sustaining applications. Customers using or selling these products for use in such applications do so at their own risk and agree to fully indemnify TSC for any damages resulting from such improper use or sale.