

1.1 Scope.

This specification covers the detail requirements for a monolithic CMOS 14-bit digital-to-analog converter. The device is configured to accept right-justified data in two bytes from an 8-bit data bus. A novel low-leakage configuration enables the AD7534 to exhibit excellent output leakage current characteristics over the specified temperature range.

1.2 Part Number.

The complete part numbers per Table 1 of this specification are as follows:

Device	Part Number
- 1	AD7534SQ/883B
- 2	AD7534TQ/883B

1.2.3 Case Outline.

See Appendix 1 of General Specification ADI-M-1000: package outline: Q-20

1.3 Absolute Maximum Ratings. ($T_A = +25^\circ\text{C}$ unless otherwise noted)

V_{DD} (Pin 19) to DGND	-0.3V, +17V
V_{SS} (Pin 20) to AGND	-15V, +0.3V
V_{REF} (Pin 1) to AGND	$\pm 25\text{V}$
V_{RFB} (Pin 2) to AGND	$\pm 25\text{V}$
Digital Input Voltage (Pins 7-18) to DGND	-0.3V, V_{DD}
V_{PIN3} to DGND	-0.3V, V_{DD}
AGND to DGND	-0.3V, V_{DD}
Power Dissipation	
Up to $+75^\circ\text{C}$	450mW
Derates above $+75^\circ\text{C}$	6mW/ $^\circ\text{C}$
Operating Temperature Range	-55°C to $+125^\circ\text{C}$
Storage Temperature	-65°C to $+150^\circ\text{C}$
Lead Temperature (Soldering 10sec)	$+300^\circ\text{C}$

1.5 Thermal Characteristics.

Thermal Resistance $\theta_{JC} = 35^\circ\text{C}/\text{W}$
 $\theta_{JA} = 120^\circ\text{C}/\text{W}$

AD7534—SPECIFICATIONS

Table 1.

Test	Symbol	Device ²	Design Limit $T_{min}-T_{max}$	Sub Group 1	Sub Group 2, 3	Sub Group 4	Test Condition ¹	Units
Resolution	RES	-1, 2	14					Bits
Relative Accuracy	RA	-1 -2	± 2 ± 1	± 2 ± 2	± 2 ± 1	± 1		LSB max
Differential Nonlinearity	DNL	-1, 2	± 1	± 1	± 1	± 1	Guaranteed Monotonic to 14-Bits	LSB max
Gain Error ²	A _B	-1 -2	± 8 ± 4	± 8 ± 8	± 8 ± 4	± 4		LSB max
Gain Tempco	TC _{AB}	-1 -2	± 5 ± 2.5					ppm/°C max
Supply Rejection (Δ Gain/ Δ V _{DD})		-1, 2	± 0.02	± 0.01	± 0.02		$\Delta V_{DD} = \pm 5\%$	% per % max
Output Leakage Current (Pin 3)	I _{OUT}	-1, 2	± 20	± 5	± 20		V _{SS} = -300mV (DAC Register Loaded with All 0's)	nA max
		-1, 2	± 150	± 5	± 150		V _{SS} = 0V	nA max
Output Current Settling Time @ 25°C	t _{SL}	-1, 2	1.5				To 0.003% of FSR. I _{OUT} Load = 100Ω, C _{EXT} = 13pF. DAC Register Alternately Loaded with All 1's and All 0's.	μs max
Feedthrough Error ³	FT	-1, 2	10				V _{REF} = ± 10 V, 10kHz Sine Wave DAC Register Loaded with All 0's	mV p-p max
Input Resistance, Pin 1	R _{IN}	-1, 2	3.5 10	3.5 10	3.5 10		Typical Input Resistance = 6kΩ	kΩ min kΩ max
Input High Voltage	V _{IH}	-1, 2	2.4	2.4	2.4			V min
Input Low Voltage	V _{IL}	-1, 2	0.8	0.8	0.8			V max
Input Leakage Current	I _{IN}	-1, 2	± 10	± 1	± 10		V _{IN} = 0V or V _{DD}	μA max
Input Capacitance	C _{IN}	-1, 2	7					pF max
Analog Output Capacitance: (Pin 3)	C _{OUT}	-1, 2	260 130				DAC Register Loaded with All 1's DAC Register Loaded with All 0's	pF max
Address Valid to Write Setup Time	t _{AWS}	-1, 2	0					ns min
Address Valid to Write Hold Time	t _{AWH}	-1, 2	0					ns min
Data Setup Time	t _{DS}	-1, 2	180					ns min
Data Hold Time	t _{DH}	-1, 2	30					ns min
Chip Select to Write Setup Time	t _{CWS}	-1, 2	0					ns min
Chip Select to Write Hold Time	t _{CWH}	-1, 2	0					ns min
Write Pulse Width	t _{WR}	-1, 2	240					ns min
Power Supply Voltage Range	V _{DD}	-1, 2	11.4 15.75				Specs Guaranteed Over This Range	V min V max
	V _{SS}	-1, 2	-200 -500				Specs Guaranteed Over This Range	mV min mV max
Power Supply Current	I _{DD}	-1, 2	3 500	3 500	3 500		All Digital Inputs V _{IL} or V _{IH} All Digital Inputs 0 or V _{DD}	mA max μA max

NOTES

- ¹V_{DD} = +12V to 15V; V_{REF} = +10V, V_{PIN3} = V_{PIN4} = 0V, V_{AS} = -300mV unless otherwise stated.
- Specifications are guaranteed for a V_{DD} of +12V to +15V with a tolerance of $\pm 5\%$; testing is performed at 12V and 15V only. At V_{DD} = 5V, the device is fully functional with a slight degradation in performance.
- ²Measured using internal feedback resistor and includes effects of leakage current and gain T.C.
- ³Feedthrough can be further reduced by connecting the metal lid to ground.

3.2.1 Functional Block Diagram and Terminal Assignments.

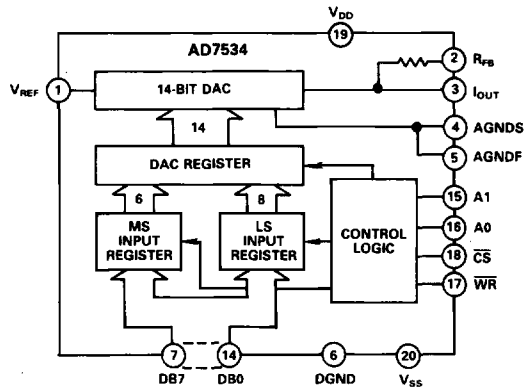

3.2.4 Microcircuit Technology Group.

This microcircuit is covered by technology group (81).

4.2.1 Life Test/Burn-In Circuit.

Steady state life test is per MIL-STD-883, Method 1005. Burn-in is per MIL-STD-883 Method 1015, Test Condition (B).

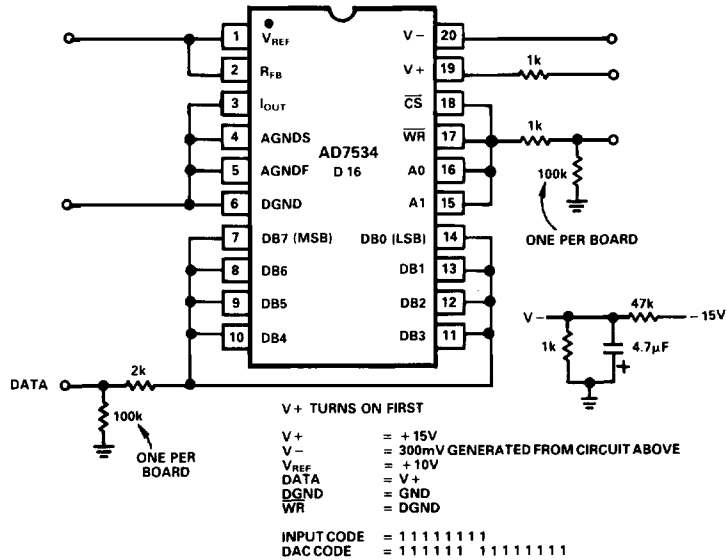

8
DIGITAL-TO-ANALOG CONVERTERS