

TQP7M9104

2W High Linearity Amplifier



Applications

- Repeaters
- BTS Transceivers
- BTS High Power Amplifiers
- CDMA / WCDMA / LTE
- General Purpose Wireless

Product Features

- 700-2700 MHz
- +32.8 dBm P1dB
- +49.5 dBm Output IP3
- 15.8 dB Gain at 2140 MHz
- +5V Single Supply, 435 mA Collector Current
- Internal RF overdrive protection
- Internal DC overvoltage protection
- Internal Active Bias
- On chip ESD protection
- Shut-down Capability
- Capable of handling 10:1 VSWR at 5Vcc, 2.14 GHz, 32.8 dBm CW Pout or 23.5 dBm WCDMA Pout

General Description

The TQP7M9104 is a high linearity driver amplifier in industry standard, RoHS compliant, QFN surface mount package. This InGaP/GaAs HBT delivers high performance across 700-2700 MHz range of frequencies with 15.8 dB Gain, +49.5 dBm OIP3 and +32.5 dBm P1dB at 2.14 GHz while only consuming 435 mA quiescent collector current. All devices are 100% RF and DC tested.

The TQP7M9104 incorporates on-chip features that differentiate it from other products in the market. The amplifier integrates an on-chip DC over-voltage and RF over-drive protection. This protects the amplifier from electrical DC voltage surges and high input RF input power levels that may occur in a system.

The TQP7M9104 is targeted for use as a driver amplifier in wireless infrastructure where high linearity, medium power, and high efficiency are required. The device is an excellent candidate for transceiver line cards and high power amplifiers in current and next generation multi-carrier 3G / 4G base stations.

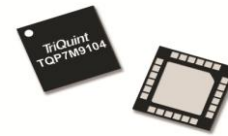

24-pin QFN 4x4mm SMT Package

Functional Block Diagram

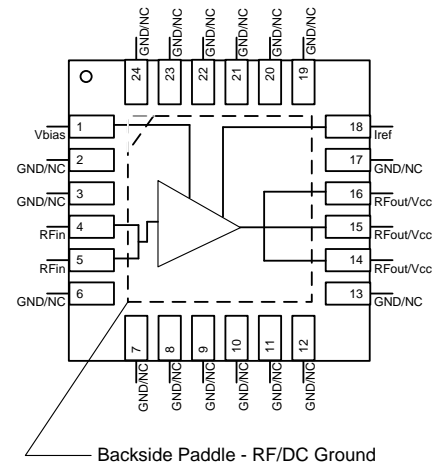

Pin Configuration

| Pin # | Symbol |
|--|--------------|
| 1 | Vbias |
| 4, 5 | RFIn |
| 14, 15, 16 | RFout/Vcc |
| 18 | Iref |
| 2, 3, 6, 7, 8, 9, 10, 11, 12, 13, 17, 19, 20, 21, 22, 23, 24 | GND / NC |
| Backside Paddle | RF/DC Ground |

Ordering Information

| Part No. | Description |
|-------------------|-----------------------------|
| TQP7M9104 | 2W High Linearity Amplifier |
| TQP7M9104-PCB900 | 920-960MHz EVB |
| TQP7M9104-PCB2140 | 2.11-2.17GHz EVB |

Standard T/R size =2500 pieces on a 13" reel.

TQP7M9104

2W High Linearity Amplifier



Specifications

Absolute Maximum Ratings

| Parameter | Rating |
|--------------------------|---------------|
| Storage Temperature | -65 to +150°C |
| Device Voltage, V_{CC} | 6.5 V |
| Maximum Input Power, CW | +30 dBm |

Operation of this device outside the parameter ranges given above may cause permanent damage.

Recommended Operating Conditions

| Parameter | Min | Typ | Max | Units |
|--------------------------------|-----|-----|-------|-------|
| V_{CC} | | +5 | +5.25 | V |
| T_{case} | -40 | | +85 | °C |
| T_j (for $>10^6$ hours MTTF) | | | 170 | °C |

Electrical specifications are measured at specified test conditions.

Specifications are not guaranteed over all recommended operating conditions.

Electrical Specifications

Test Conditions: $V_{CC} = +5V$, $I_{CQ} = 435$ mA, $T = 25^\circ C$ using a TQP7M9104-PCB2140 application circuit.

| Parameter | Conditions | Min | Typical | Max | Units |
|--|---|-------|---------|------|-------|
| Operational Bandwidth | | 700 | | 2700 | MHz |
| Test Frequency | | | 2140 | | MHz |
| Power Gain | | 14.3 | 15.8 | 17.3 | dB |
| Input Return Loss | | | 12 | | dB |
| Output Return Loss | | | 9.5 | | dB |
| Output IP3 | $P_{out} = +17$ dBm/tone, $\Delta f = 1$ MHz | +45.5 | +49.5 | | dBm |
| WCDMA Channel Power ⁽¹⁾ | at -50 dBc ACLR | | +23.8 | | dBm |
| Output P1dB | | +32 | +32.8 | | dBm |
| Noise Figure | | | 4.4 | | dB |
| Quiescent Collector Current, I_{CQ} | | 355 | 435 | 490 | mA |
| V_{CC} | | | +5 | | V |
| I_{ref} | | | 19 | | mA |
| Thermal Resistance (jnc to case) θ_{jc} | | | 15.7 | | °C/W |

Notes:

1. ACLR Test set-up: 3GPP WCDMA, TM1+64 DPCH, +5 MHz offset, PAR = 9.7 dB at 0.01% Prob.

TQP7M9104

2W High Linearity Amplifier



Device Characterization Data

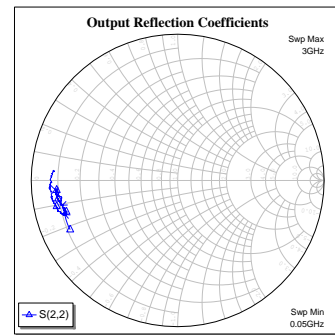
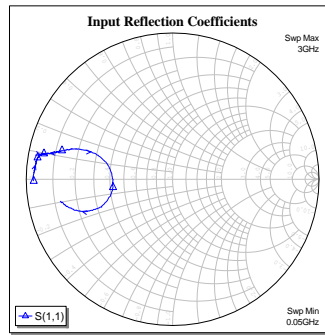
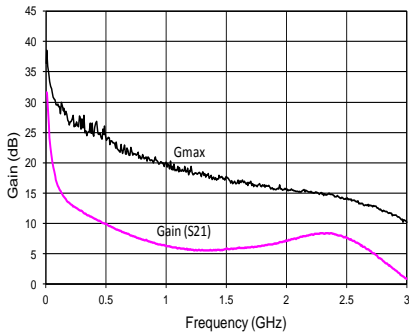

S-Parameter Data

$V_{cc} = +5\text{ V}$, $I_{cq} = 435\text{ mA}$, $I_{ref} = 19\text{ mA}$, $T = +25^\circ\text{ C}$, unmatched 50 ohm system, calibrated to device leads

| Freq (MHz) | S11 (dB) | S11 (ang) | S21 (dB) | S21 (ang) | S12 (dB) | S12 (ang) | S22 (dB) | S22 (ang) |
|------------|----------|-----------|----------|-----------|----------|-----------|----------|-----------|
| 50 | -0.4553 | -179.26 | 20.126 | 118.98 | -43.273 | 4.1446 | -1.8524 | -155.37 |
| 100 | -0.4348 | 178.69 | 15.971 | 124.23 | -42.615 | -1.4433 | -1.8878 | -166.21 |
| 200 | -0.4583 | 176.36 | 13.24 | 126.46 | -40.235 | 2.3772 | -1.859 | -172.01 |
| 400 | -0.5124 | 173.38 | 10.778 | 118.38 | -40.956 | 0.7196 | -1.5792 | -174.84 |
| 600 | -0.5796 | 171.48 | 8.9263 | 108.51 | -41.682 | 10.901 | -1.6005 | -175.51 |
| 800 | -0.6594 | 170.04 | 7.3201 | 100.05 | -42.533 | -8.3414 | -1.6164 | -174.73 |
| 1000 | -0.7617 | 169.21 | 6.2878 | 93.94 | -42.841 | 6.4435 | -1.531 | -173.74 |
| 1200 | -0.8777 | 168.95 | 5.7693 | 89.116 | -40.461 | 3.1558 | -1.6296 | -171.43 |
| 1400 | -1.1121 | 168.56 | 5.5556 | 83.209 | -39.435 | -0.2787 | -1.7656 | -170.12 |
| 1600 | -1.4274 | 167.84 | 6.0222 | 74.67 | -41.097 | -1.3568 | -1.8812 | -167.74 |
| 1800 | -1.9525 | 165.88 | 6.3509 | 63.971 | -37.935 | -22.971 | -1.951 | -165.22 |
| 2000 | -3.0149 | 163.02 | 7.1412 | 51.862 | -36.666 | -37.917 | -1.9853 | -163.19 |
| 2200 | -5.3234 | 162.27 | 8.1891 | 30.583 | -35.423 | -57.21 | -1.7616 | -163.18 |
| 2400 | -7.8162 | -179.65 | 8.2216 | 2.8455 | -35.631 | -78.615 | -1.5099 | -167.05 |
| 2600 | -5.6951 | -159.12 | 6.6099 | -26.943 | -35.017 | -113.27 | -1.2811 | -172.58 |
| 2800 | -3.2673 | -161.75 | 3.8288 | -51.412 | -37.551 | -151.24 | -1.2268 | -179.96 |
| 3000 | -2.1416 | -169.16 | 0.9043 | -67.725 | -39.417 | -168.38 | -1.4503 | 175.32 |

TQP7M9104

2W High Linearity Amplifier



Reference Design 869-894 MHz

Typical Performance at 25 °C

| Frequency (MHz) | 869 | 880 | 894 | Units |
|---|-------|-------|-------|-------|
| Gain | 20.8 | 20.8 | 20.8 | dB |
| Input Return Loss | -13.3 | -13 | -11.5 | dB |
| Output Return Loss | -7.7 | -8.6 | -9.8 | dB |
| Output P1dB | +34.3 | +34.1 | +33.8 | dBm |
| Output IP3 (+23 dBm/1tone, Δf = 1 MHz) | +44.9 | +44.9 | +44.7 | dBm |
| WCDMA Channel Power (at -50 dBc ACLR) | 22 | 22.5 | 23 | dB |
| Supply Voltage, Vcc | +5 | | | V |
| Quiescent Current, Icq | 435 | | | mA |
| Reference Current, Iref | 19 | | | mA |

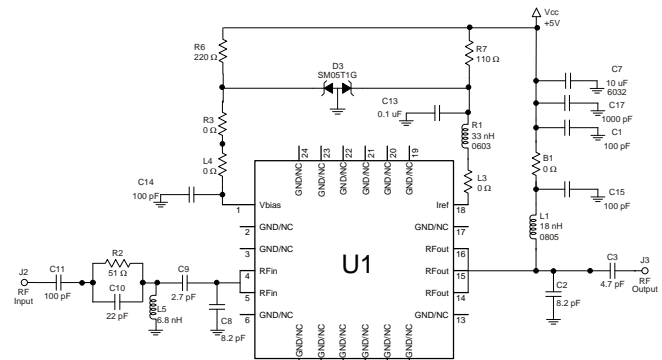

Notes:

- Components shown on the silkscreen but not on the schematic are not used.
- 0 Ω resistors may be replaced with copper trace in the target application layout.
- Iref can be used as device power down current by placing R7 at location R8.
- The recommended component values are dependent upon the frequency of operation.
- All components are of 0603 size unless stated on the schematic.
- R1 is critical for device linearity performance.
- Critical component placement locations:
 Distance between center of C8 and U1 device package is 243 mil (11° at 880MHz)
 Distance between center of L5 and U1 device package is 452 mil (20.5° at 880MHz)
 Distance between center of C2 and U1 device package is 355 mil (16.1° at 880MHz)
 Distance between center of C9 and U1 device package is 275 mil (12.4° at 880MHz)

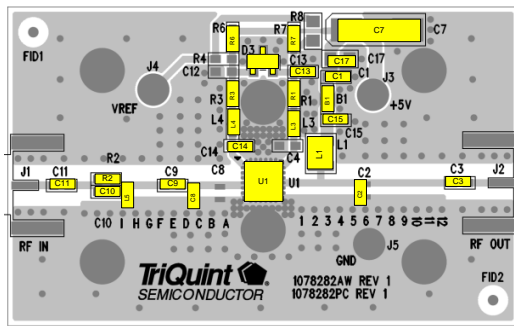

RF Performance Plots 869-894 MHz

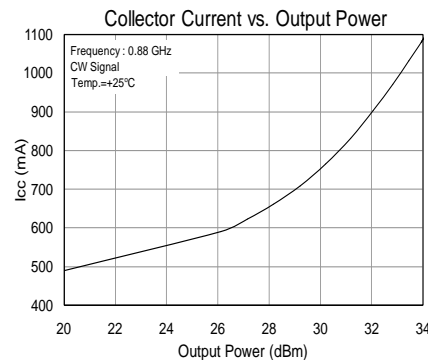
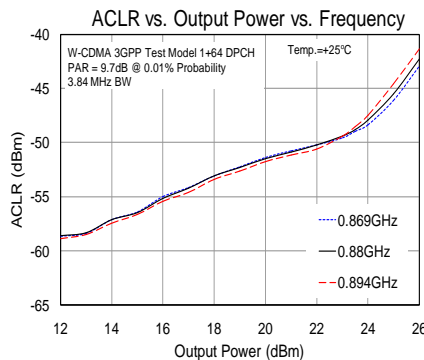
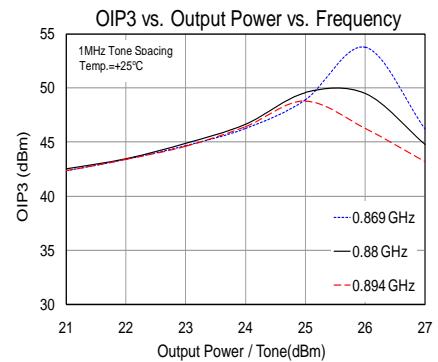
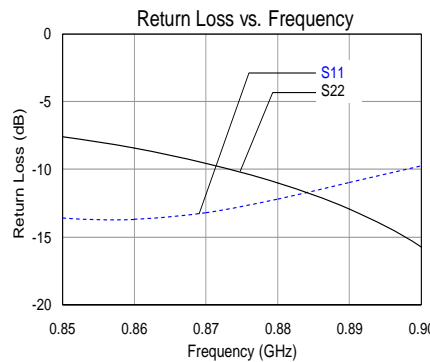
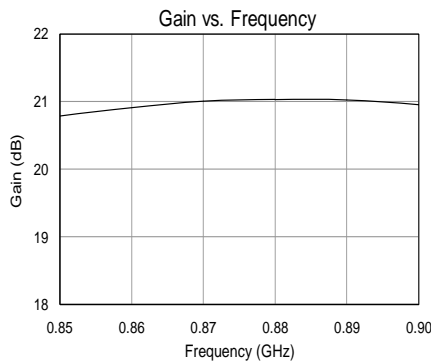

TQP7M9104

2W High Linearity Amplifier



Application Circuit 920-960 MHz (TQP7M9104-PCB900)

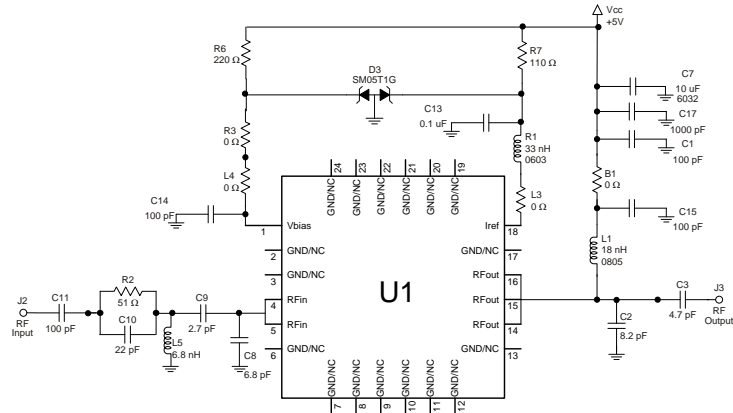
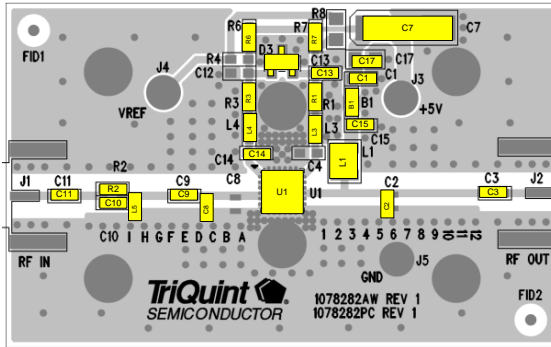

Notes:

1. See PC Board Layout under Application Information section for more information.
2. Components shown on the silkscreen but not on the schematic are not used.
3. 0 Ω resistors may be replaced with copper trace in the target application layout.
4. Iref can be used as device power down current by placing R7 at location R8.
5. The recommended component values are dependent upon the frequency of operation.
6. All components are of 0603 size unless stated on the schematic.
7. R1 is critical for device linearity performance.
8. Critical component placement locations:
 Distance between center of C8 and U1 device package is 190 mil (9.2° at 940MHz)
 Distance between center of L5 and U1 device package is 452 mil (21.8° at 940MHz)
 Distance between center of C2 and U1 device package is 305 mil (14.7° at 940MHz)
 Distance between center of C9 and U1 device package is 275 mil (13.3° at 940MHz)

Bill of Material

| Ref Des | Value | Description | Manuf. | Part Number |
|---------------------|--------------|--|-----------|----------------|
| n/a | n/a | Printed Circuit Board | TriQuint | 1078282 |
| n/a | n/a | Printed Circuit Board | TriQuint | 1078282 |
| D3 | n/a | Zener, dual, SOT-23 | various | |
| C9 | 2.7 pF | Capacitor, Chip, 0603, ± 0.05 pF, 50 V, Accu-P | AVX | 06035J2R7ABSTR |
| B1, L3, L4, R3 | 0 Ω | Resistor, Chip, 0603, 5%, 1/16W | various | |
| L5 | 6.8 nH | Inductor, 0603, 5% | Toko | LL1608-FSL6N8 |
| C3 | 4.7 pF | Capacitor, Chip, 0603, ± 0.05 pF, 50 V, Accu-P | AVX | 06035J4R7ABSTR |
| C2, C8 | 8.2 pF | Capacitor, Chip, 0603, ± 0.05 pF, 50 V, Accu-P | AVX | 06035J8R2ABSTR |
| C10 | 22 pF | Capacitor, Chip, 0603, 5%, 50 V, NPO/COG | various | |
| C1, C11, C14, C15 | 100 pF | Capacitor, Chip, 0603, 5%, 50V, NPO/COG | various | |
| L1 | 18 nH | Inductor, 1008, 5%, Coilcraft CS Series | Coilcraft | 1008HQ-18NXJL |
| C17 | 1000 pF | Capacitor, Chip, 0603, 10%, 50V, NPO/COG | various | |
| C13 | 0.1 uF | Capacitor, Chip, 0603, 50V, X5R, 10% | various | |
| C7 | 10 uF | Capacitor, Tantalum, 6032, 35V, 10% | various | |
| R2 | 51 Ω | Resistor, Chip, 0603, 5%, 1/16W | various | |
| R6 | 220 Ω | Resistor, Chip, 0603, 1%, 1/16W | various | |
| R7 | 110 Ω | Resistor, Chip, 0603, 1%, 1/16W | various | |
| R1 | 33 nH | Inductor, 0603, 5% | Toko | LL1608-FSL33N |
| R8, R4, C12, C4, D3 | n/a | Do Not Place | | |

TQP7M9104

2W High Linearity Amplifier



Typical Performance 920-960 MHz

Typical Performance at 25 °C

| Frequency (MHz) | 920 | 940 | 960 | Units |
|---|-------|-------|-------|-------|
| Gain | 20.8 | 21 | 21 | dB |
| Input Return Loss | -13 | -12 | -11 | dB |
| Output Return Loss | -9 | -11.8 | -15 | dB |
| Output P1dB | +33.9 | +33.8 | +33.4 | dBm |
| Output IP3 (+23 dBm/tone, Δf = 1 MHz) | +45 | +45 | +45 | dBm |
| WCDMA Channel power (at -50 dBc ACLR) [1] | +24 | +23.5 | +23 | dBm |
| Supply Voltage, Vcc | +5 | | | V |
| Quiescent Collector Current, Icq | 435 | | | mA |
| Reference Current, Iref | 19 | | | mA |

Notes:

1. ACLR Test set-up: 3GPP WCDMA, TM1+64 DPCH, +5 MHz offset, PAR = 9.7 dB at 0.01% Prob.

RF Performance Plots 920-960 MHz

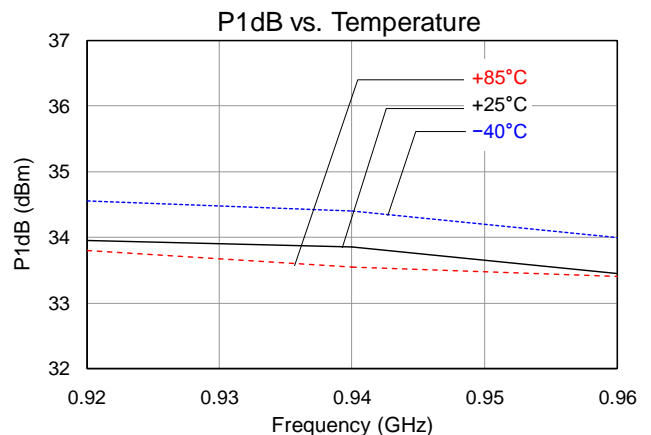
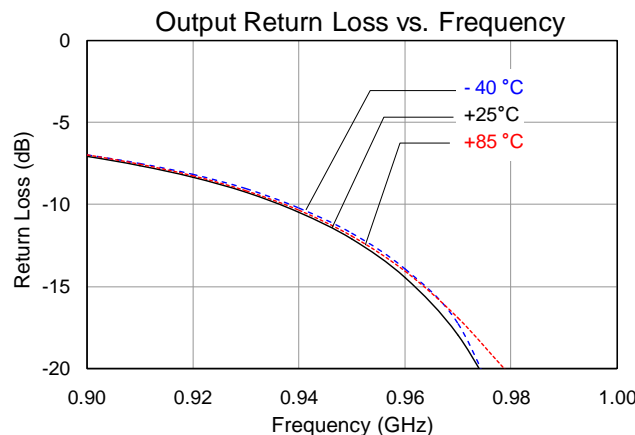
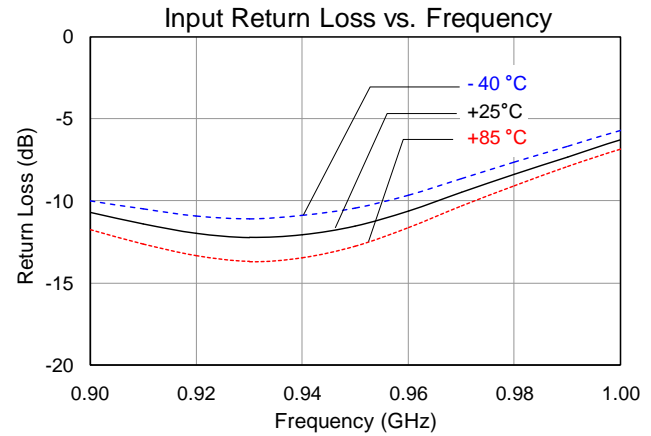
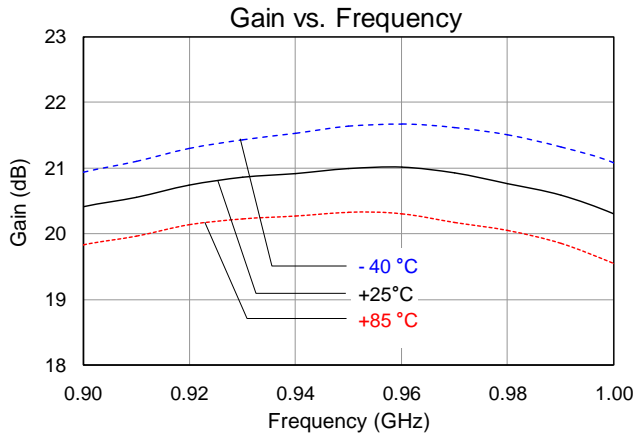

TQP7M9104

2W High Linearity Amplifier

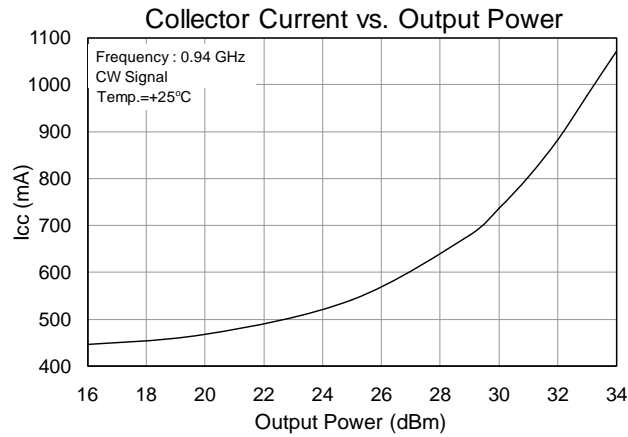
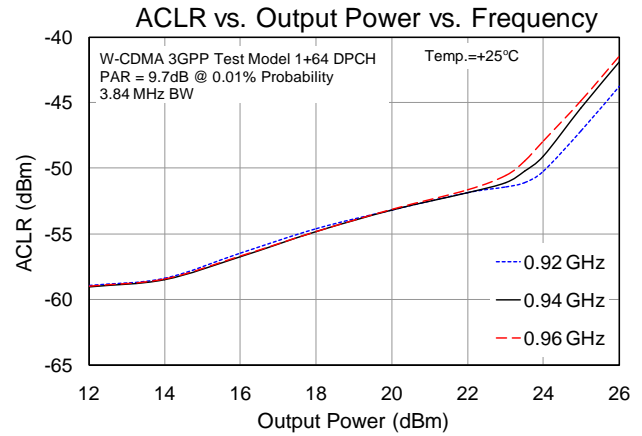
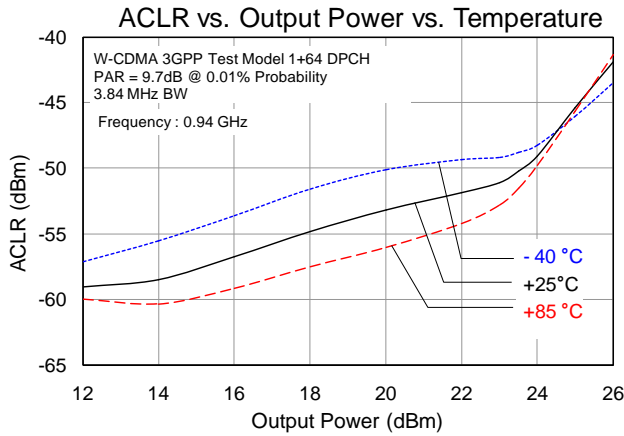
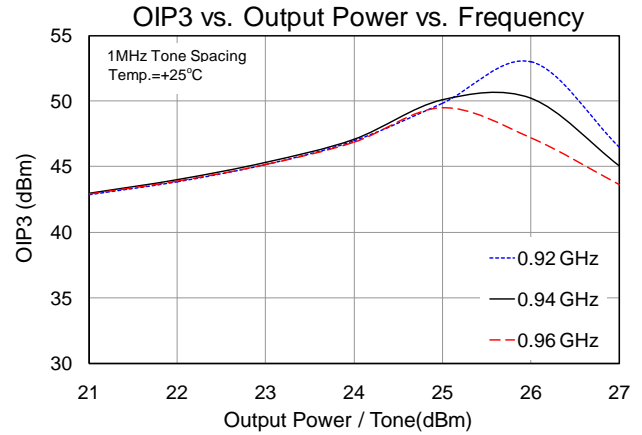
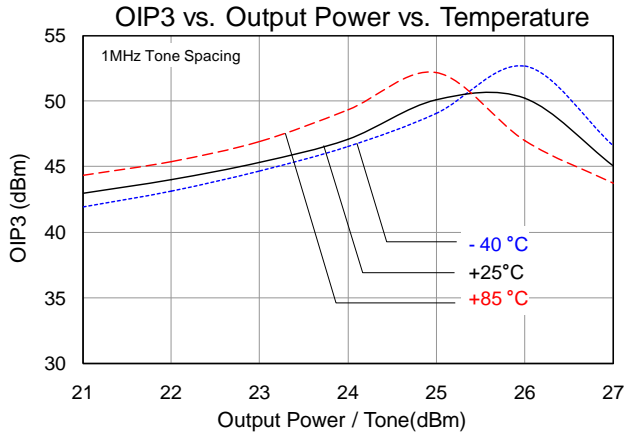

TQP7M9104

2W High Linearity Amplifier



Application Circuit 2110-2170 MHz (TQP7M9104-PCB2140)

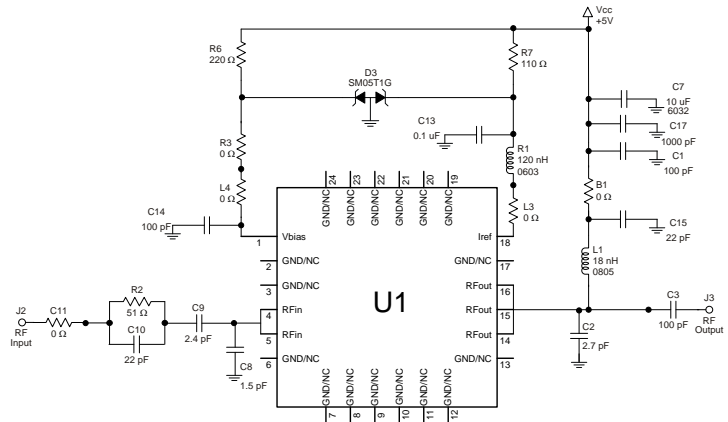
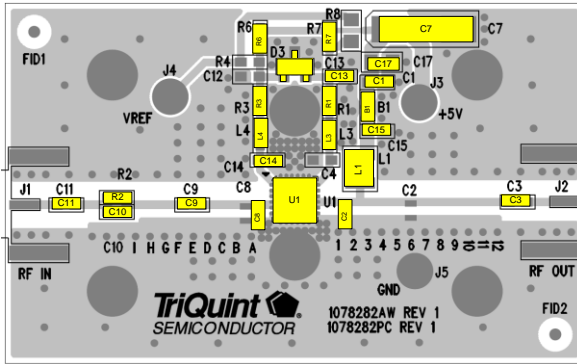

Notes:

1. See PC Board Layout under Application Information section for more information.
2. Components shown on the silkscreen but not on the schematic are not used.
3. 0 Ω resistors may be replaced with copper trace in the target application layout.
4. Iref can be used as device power down current by placing R7 at location R8.
5. The recommended component values are dependent upon the frequency of operation.
6. All components are of 0603 size unless stated on the schematic.
7. R1 is critical for device linearity performance.
8. Critical component placement locations:
 Distance between center of C8 and U1 device package is 50 mil (5.5° at 2140MHz)
 Distance between center of C2 and U1 device package is 113 mil (12.4° at 2140MHz)
 Distance between center of C9 and U1 device package is 275 mil (30.3° at 2140MHz)

Bill of Material

| Ref Des | Value | Description | Manuf. | Part Number |
|---------------------|---------|---|-----------|----------------|
| U1 | n/a | 2W High Linearity Amplifier | TriQuint | TQP7M9104 |
| n/a | n/a | Printed Circuit Board | TriQuint | 1078282 |
| D3 | n/a | Zener, dual, SOT-23 | various | |
| C8 | 1.5 pF | Capacitor, Chip, 0603, ±0.05pF, 50V, Accu-P | AVX | 06035J1R5ABSTR |
| C9 | 2.4 pF | Capacitor, Chip, 0603, ±0.05pF, 50V, Accu-P | AVX | 06035J2R4ABSTR |
| C2 | 2.7 pF | Capacitor, Chip, 0603, ±0.05pF, 50V, Accu-P | AVX | 06035J2R7ABSTR |
| B1, L3, L4, R3, C11 | 0 Ω | Resistor, Chip, 0603, 5%, 1/16W | various | |
| C10, C15 | 22 pF | Capacitor, Chip, 0603, 5%, 50V, NPO/COG | various | |
| C1, C14, C3 | 100 pF | Capacitor, Chip, 0603, 5%, 50V, NPO/COG | various | |
| L1 | 18 nH | Inductor, 1008, 5%, Ceramic | Coilcraft | 1008HQ-18NXJL |
| C17 | 1000 pF | Capacitor, Chip, 0603, 10%, 50V, NPO/COG | various | |
| C13 | 0.1 uF | Capacitor, Chip, 0603, 10%, 50V, X5R | various | |
| C7 | 10 uF | Capacitor, Tantalum, 6032, 20 %, 50V | various | |
| R2 | 51 Ω | Resistor, Chip, 0603, 5%, 1/16W | various | |
| R6 | 220 Ω | Resistor, Chip, 0603, 1%, 1/16W | various | |
| R7 | 110 Ω | Resistor, Chip, 0603, 1%, 1/16W | various | |
| R1 | 120 nH | Inductor, 0603, 5% | Toko | LL1608-FSR12J |
| R8, R4, C12, C4, D3 | n/a | Do Not Place | | |

TQP7M9104

2W High Linearity Amplifier



Typical Performance 2110-2170 MHz

| Frequency | MHz | 2110 | 2140 | 2170 |
|---|-----|-------|-------|-------|
| Gain | dB | 15.8 | 15.8 | 15.8 |
| Input Return Loss | dB | -12.4 | -12.0 | -11.8 |
| Output Return Loss | dB | -8.7 | -9.5 | -10.5 |
| Output P1dB | dBm | +32.9 | +32.8 | +32.8 |
| Output IP3 (+17 dBm/tone, $\Delta f = 1$ MHz) | dBm | +49 | +49.5 | +50 |
| WCDMA Channel power (at -50 dBc ACLR) [1] | dBm | +23.5 | +23.8 | +24.0 |
| Noise Figure | dB | 4.4 | 4.4 | 4.6 |
| Supply Voltage, Vcc | V | +5 | | |
| Quiescent Collector Current, Icq | mA | 435 | | |
| Reference Current, Iref | mA | 19 | | |

Notes:

1. ACLR Test set-up: 3GPP WCDMA, TM1+64 DPCH, +5 MHz offset, PAR = 9.7 dB at 0.01% Prob.

RF Performance Plots 2110-2170 MHz

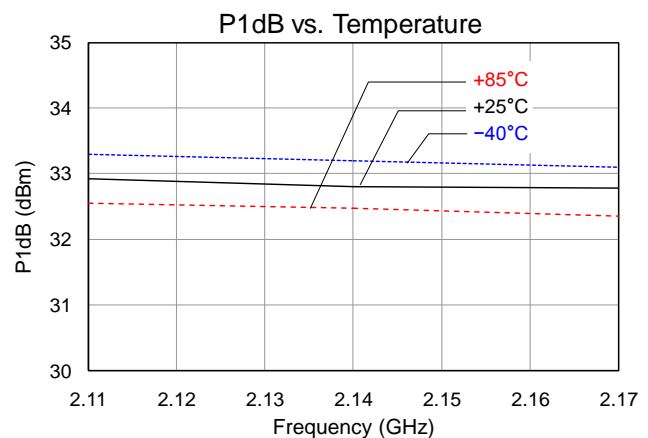
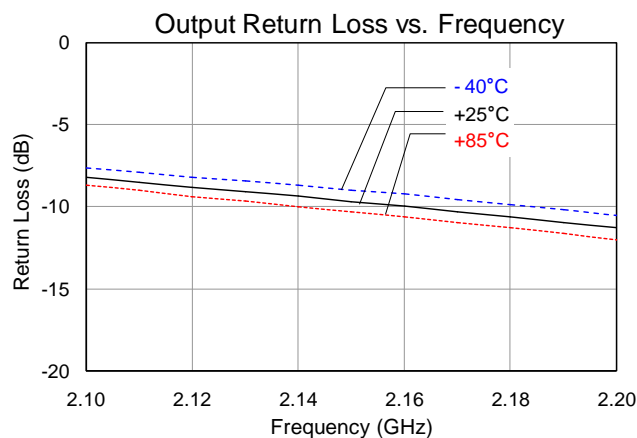
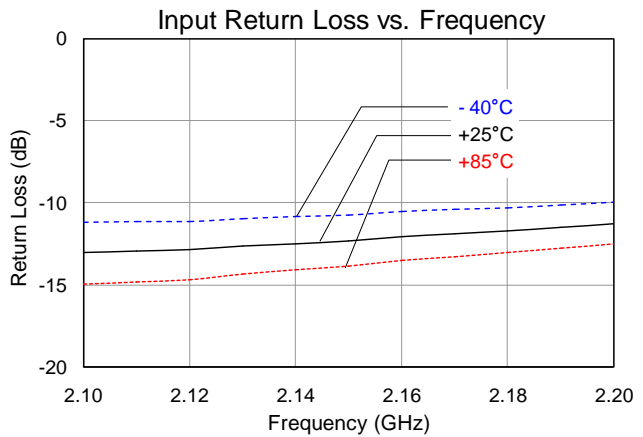
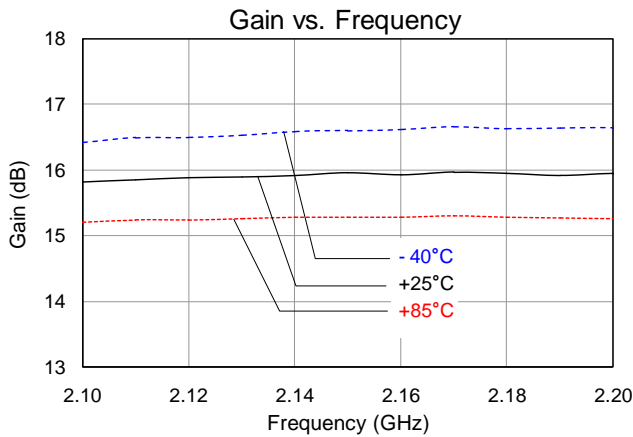

TQP7M9104

2W High Linearity Amplifier

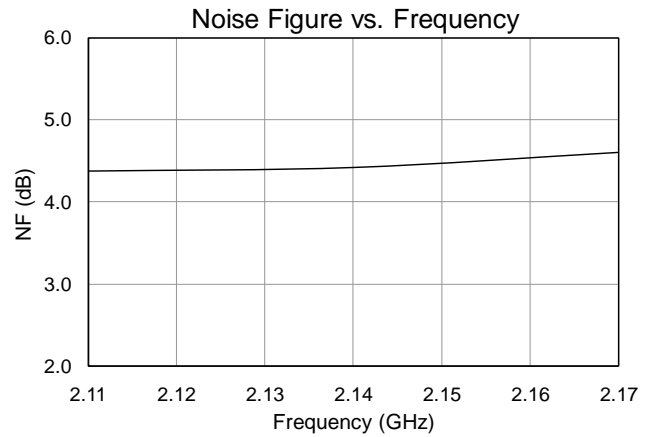
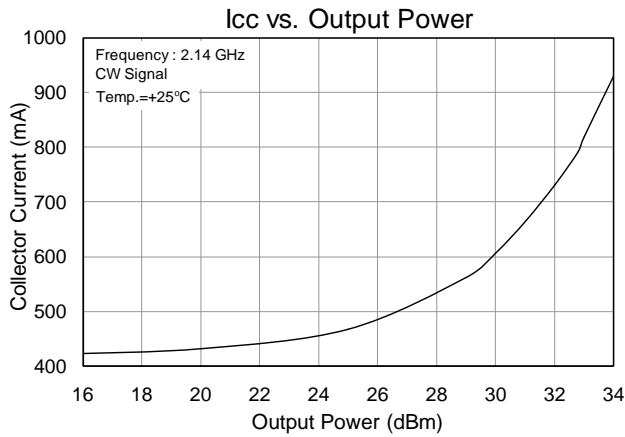
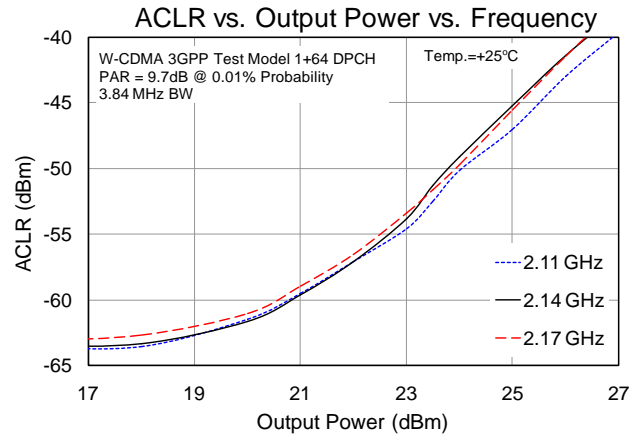
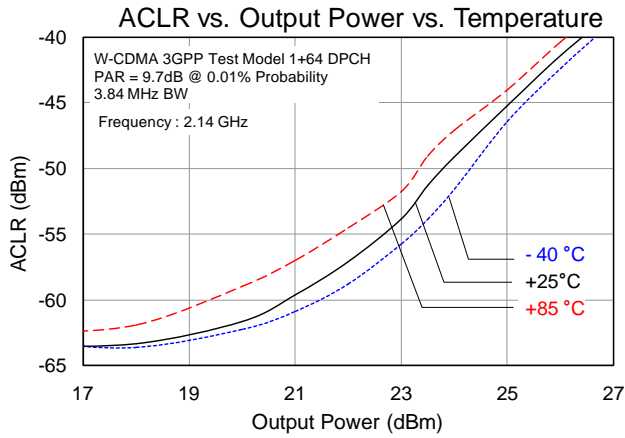
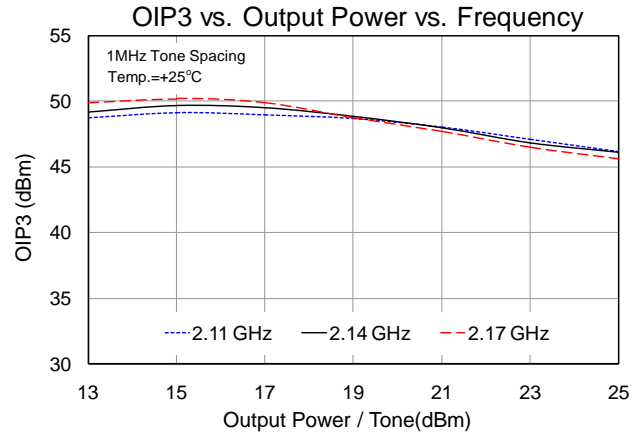
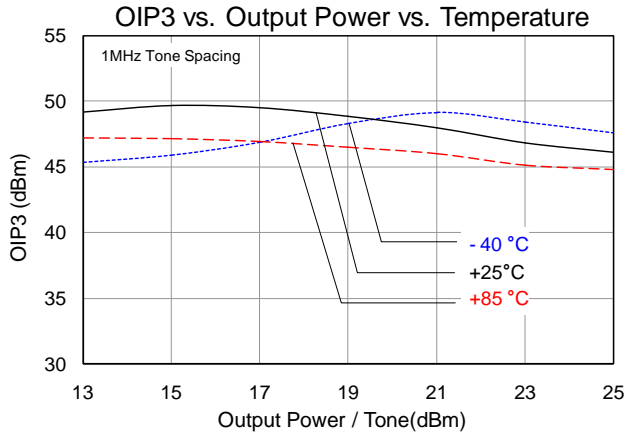

TQP7M9104

2W High Linearity Amplifier



Pin Configuration and Description

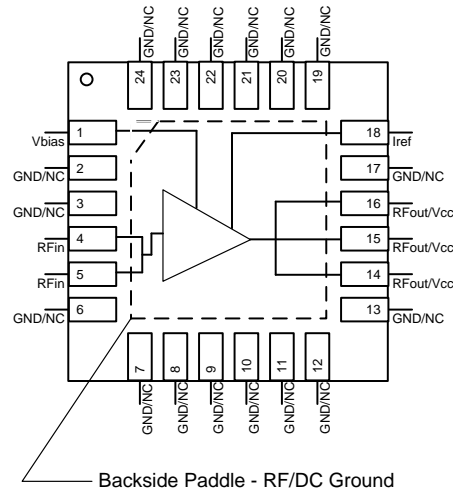

| Pin | Symbol | Description |
|--|-------------|---|
| 1 | Vbias | Voltage supply for active bias for the amp. Connect to same supply voltage as Vcc. |
| 2, 3, 6, 7, 8, 9, 10, 11, 12, 13, 17, 19, 20, 21, 22, 23, 24 | GND/NC | No internal connection. This pin can be grounded or N/C on PCB. Land pads should be provided for PCB mounting integrity. |
| 4, 5 | RFin | RF Input. DC voltage present, blocking capacitor required. Requires external match for optimal performance. |
| 14, 15, 16 | RFout / Vcc | RF Output. DC Voltage present, blocking cap required. Requires external match for optimal performance. |
| 18 | Iref | Reference current into internal active bias current mirror. Current into Iref sets device quiescent current. Also, can be used as on/off control. |
| Backside paddle | RF/DC GND | Multiple Vias should be employed to minimize inductance and thermal resistance. Use recommended via pattern shown under mounting configuration and ensure good solder attach for optimum thermal and electrical performance |

Evaluation Board PCB Information

TriQuint PCB 1080068 Material and Stack-up

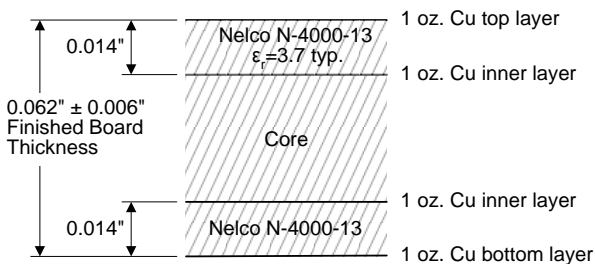

50 ohm line dimensions: width = .031"
spacing = .035".

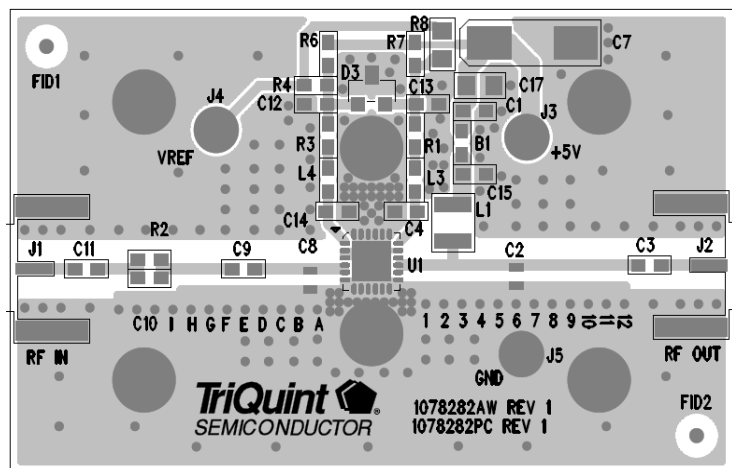

TQP7M9104

2W High Linearity Amplifier



Mechanical Information

Package Marking and Dimensions

Package Marking:

Part number – 7M9104
 Year, week - YYWW
 Assembly code - XXXXX

NOTES:

- EXCEPT WHERE NOTED, THIS PART OUTLINE CONFORMS TO JEDEC STANDARD MO-220, ISSUE E (VARIATION VGCC) FOR THERMALLY ENHANCED PLASTIC VERY THIN FINE PITCH QUAD FLAT NO LEAD PACKAGE (QFN).
- DIMENSIONING & TOLERANCING CONFORM TO ASME Y14.4M-1994.
- ALL DIMENSIONS ARE IN MILLIMETERS. ANGLES ARE IN DEGREES.
- THE TERMINAL #1 IDENTIFIER AND TERMINAL NUMBERING CONVENTION CONFORM TO JEDEC 95-1 SPP-012.
- COPLANARITY APPLIES TO THE EXPOSED GROUND/THERMAL PAD AS WELL AS THE TERMINALS.
- PACKAGE BODY LENGTH/WIDTH DOES NOT INCLUDE PLASTIC FLASH PROTRUSION ACROSS MOLD PARTING LINE.
- DEVIATION FROM JEDEC STANDARD MO-229, ISSUE C, 12 LEAD COUNT NOT

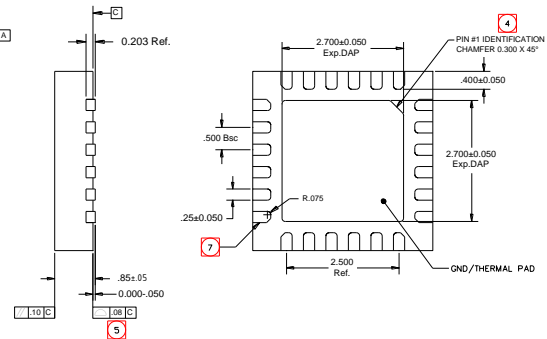
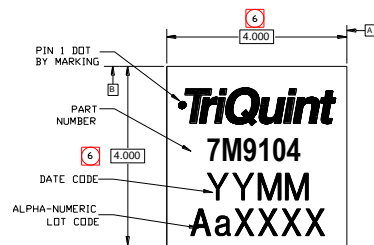

PCB Mounting Pattern

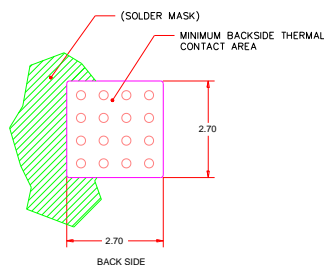
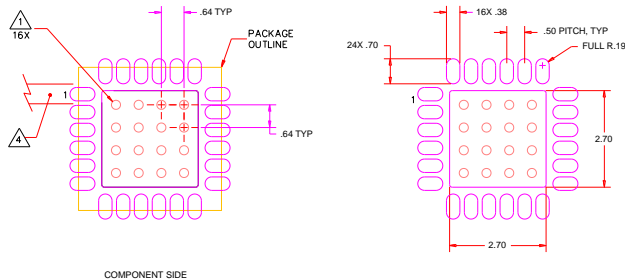

NOTES:

- GROUND/THERMAL VIAS ARE CRITICAL FOR THE PROPER PERFORMANCE OF THIS DEVICE. VIAS SHOULD USE A .35mm (#80/.0135") DIAMETER DRILL AND HAVE A FINAL, PLATED THRU DIAMETER OF .25mm (.010").
- ADD AS MUCH COPPER AS POSSIBLE TO INNER AND OUTER LAYERS NEAR THE PART TO ENSURE OPTIMAL THERMAL PERFORMANCE.
- TO ENSURE RELIABLE OPERATION, DEVICE GROUND PADDLE-TO-GROUND PAD SOLDER JOINT IS CRITICAL.
- RF TRACE WIDTH DEPENDS UPON THE PC BOARD MATERIAL AND CONSTRUCTION.
- USE 1 OZ. COPPER MINIMUM.
- ALL DIMENSIONS ARE IN MILLIMETERS. ANGLES ARE IN DEGREES.

NOTES:

- The pad pattern shown has been developed and tested for optimized assembly at TriQuint Semiconductor. The PCB land pattern has been developed to accommodate lead and package tolerances. Since surface mount processes vary from supplier to supplier, careful process development is recommended.
- All dimensions are in millimeters [inches]. Angles are in degrees.
- Use 1 oz. copper minimum for top and bottom layer metal.
- Vias are required under the backside paddle of this device for proper RF/DC grounding and thermal dissipation. We recommend a 0.35mm (#80/.0135") diameter bit for drilling via holes and a final plated thru diameter of 0.25mm (0.10").
- Ensure good package backside paddle solder attach for reliable operation and best electrical performance.
- Place mounting screws near the part to fasten a back side heat sink.
- Do not apply solder mask to the back side of the PC board in the heat sink contact region.
- Ensure that the backside via region makes good physical contact with the heat sink.

Product Compliance Information

ESD Sensitivity Ratings



Caution! ESD-Sensitive Device

ESD Rating: 1C
Value: ≥ 1000 V and < 2000 V
Test: Human Body Model (HBM)
Standard: JEDEC Standard JESD22-A114

ESD Rating: IV
Value: ≥ 1000 V min
Test: Charged Device Model (CDM)
Standard: JEDEC Standard JESD22-C101

MSL Classification

MSL Rating: 1
Test: +260 °C convection reflow
Standard: JEDEC standard IPC/JEDEC J-STD-020

Solderability

Compatible with both lead-free (260 °C max. reflow temp.) and tin/lead (245 °C max. reflow temp.) soldering processes.

Package lead plating: Annealed Matte Tin over Copper

RoHS Compliance

This part is compliant with EU 2002/95/EC RoHS directive (Restrictions on the Use of Certain Hazardous Substances in Electrical and Electronic Equipment).

This product also has the following attributes:

- Lead Free
- Halogen Free (Chlorine, Bromine)
- Antimony Free
- TBBP-A (C₁₅H₁₂Br₄O₂) Free
- PFOS Free
- SVHC Free

Contact Information

For the latest specifications, additional product information, worldwide sales and distribution locations, and information about TriQuint:

Web: www.triquint.com
Email: info-sales@tqs.com

Tel: +1.503.615.9000
Fax: +1.503.615.8902

For technical questions and application information: **Email:** sicapplications.engineering@tqs.com

Important Notice

The information contained herein is believed to be reliable. TriQuint makes no warranties regarding the information contained herein. TriQuint assumes no responsibility or liability whatsoever for any of the information contained herein. TriQuint assumes no responsibility or liability whatsoever for the use of the information contained herein. The information contained herein is provided "AS IS, WHERE IS" and with all faults, and the entire risk associated with such information is entirely with the user. All information contained herein is subject to change without notice. Customers should obtain and verify the latest relevant information before placing orders for TriQuint products. The information contained herein or any use of such information does not grant, explicitly or implicitly, to any party any patent rights, licenses, or any other intellectual property rights, whether with regard to such information itself or anything described by such information.

TriQuint products are not warranted or authorized for use as critical components in medical, life-saving, or life-sustaining applications, or other applications where a failure would reasonably be expected to cause severe personal injury or death.