

TOSHIBA Bipolar Linear Integrated Circuit Silicon Monolithic

TA48L018F,TA48L02F,TA48L025F,TA48L03F,TA48L033F,TA48L05F

1.8 V, 2 V, 2.5 V, 3 V, 3.3 V, 5 V

Three-Terminal Low Dropout Voltage Regulator with Output Current of 0.15 A

The TA48L**F series consists of fixed-positive-output, low-dropout regulators and V-PNP transistors for output stage with an output current of 1 A (max). In response to the need for low-voltage and low-power dissipation devices which are used in consumer electronics and industrial appliances, the series offers devices with low output voltages: 1.8 V, 2 V, 2.5 V, 3 V, 3.3 V, 5 V.

Features

- Maximum output current: 0.15 A
- Output voltage accuracy: $V_{OUT} \pm 3\%$ (@ $T_j = 25^\circ\text{C}$)
- Low standby current: 400 μA (typ.) (@ $I_{OUT} = 0\text{ A}$)
- Low-dropout voltage: $V_D = 0.5\text{ V}$ (max) (@ $I_{OUT} = 100\text{ mA}$)
- Protection function: overheat/overcurrent
- Package type: PW-MINI (SOT-89) package

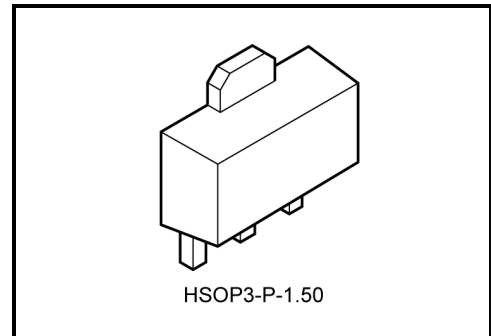

Weight: 0.05 g (typ.)

Pin Assignment/Marking

Product Name	Marking (Two digits)
TA48L018F	AI
TA48L02F	BI
TA48L025F	CI
TA48L03F	DI
TA48L033F	EI
TA48L05F	FI

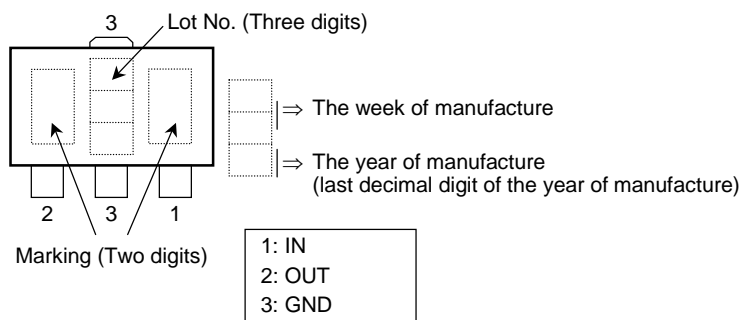

How to Order

Product No.	Package	Packing Type and Unit for Orders
TA48L**F	PW-MINI (SOT-89) Surface-mount package	On cut tape (TE12L): 100/tape section
TA48L**F (TE12L)		Embossed tape: 1000 pcs/tape

Block Diagram

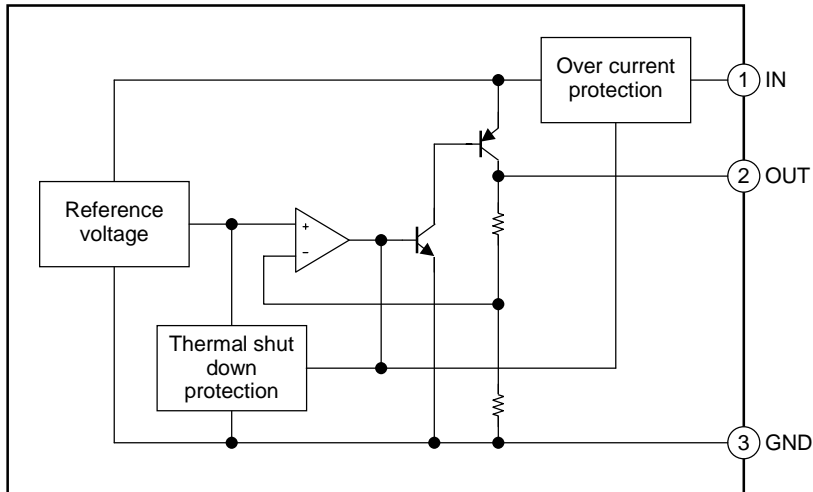

Maximum Ratings (Ta = 25°C)

Characteristics	Symbol	Rating	Unit
Input voltage	V_{IN}	16	V
Output current	I_{OUT}	0.15	A
Operating temperature	T_{opr}	-40~85	°C
Junction temperature	T_j	150	°C
Storage temperature	T_{stg}	-55~150	°C
Power dissipation	P_D	0.5	W
Thermal resistance (junction to ambient)	$P_{th(j-a)}$	250	°C/W

Note 1: Must not to apply external current and voltage (including negative voltage) to not specified pins.

Protection Function (reference)

Characteristics	Symbol	Test Condition	Min	Typ.	Max	Unit
Thermal shutdown	$T_{SD} (T_j)$	—	—	160	—	°C
Peak circuit current	I_{PEAK}	$V_{IN} = V_{OUT} + 2 V, T_j = 25^\circ C$	—	0.27	—	A
Short circuit current	I_{SC}	$V_{IN} = V_{OUT} + 2 V, T_j = 25^\circ C$	—	0.27	—	A

Note 2: When the IC is actually used, must not exceed maximum ratings.

TA48L018F

Electrical Characteristics

($C_{IN} = 0.33 \mu\text{F}$, $C_{OUT} = 3.3 \mu\text{F}$, $T_j = 25^\circ\text{C}$, unless otherwise specified)

Characteristics	Symbol	Test Conditions	Min	Typ.	Max	Unit
Output voltage	V_{OUT}	$V_{IN} = 3.8 \text{ V}$, $I_{OUT} = 40 \text{ mA}$	1.746	1.8	1.854	V
		$2.8 \text{ V} \leq V_{IN} \leq 12 \text{ V}$, $5 \text{ mA} \leq I_{OUT} \leq 100 \text{ mA}$, $0^\circ\text{C} \leq T_j \leq 125^\circ\text{C}$	1.71	1.8	1.89	
Line regulation	Reg · line	$2.8 \text{ V} \leq V_{IN} \leq 12 \text{ V}$, $I_{OUT} = 40 \text{ mA}$	—	2	20	mV
Load regulation	Reg · load	$V_{IN} = 3.8 \text{ V}$, $5 \text{ mA} \leq I_{OUT} \leq 150 \text{ mA}$	—	18	40	mV
Quiescent current	I_B	$2.8 \text{ V} \leq V_{IN} \leq 12 \text{ V}$, $I_{OUT} = 0 \text{ A}$	—	0.4	0.8	mA
		$2.8 \text{ V} \leq V_{IN} \leq 12 \text{ V}$, $I_{OUT} = 100 \text{ mA}$	—	1	5	
Starting quiescent current	I_{Bstart}	$V_{IN} = 2.1 \text{ V}$, $I_{OUT} = 0 \text{ A}$	—	0.5	1.5	mA
		$V_{IN} = 2.1 \text{ V}$, $I_{OUT} = 100 \text{ mA}$	—	5	20	
Output noise voltage	V_{NO}	$V_{IN} = 3.8 \text{ V}$, $I_{OUT} = 40 \text{ mA}$, $10 \text{ Hz} \leq f \leq 100 \text{ kHz}$	—	45	—	μV_{rms}
Ripple rejection	R.R.	$2.8 \text{ V} \leq V_{IN} \leq 12 \text{ V}$, $I_{OUT} = 40 \text{ mA}$, $f = 120 \text{ Hz}$	54	72	—	dB
Dropout voltage	V_D	$I_{OUT} = 40 \text{ mA}$	—	0.28	0.4	V
		$I_{OUT} = 100 \text{ mA}$	—	0.32	0.5	
Average temperature coefficient of output voltage	T_{CVO}	$V_{IN} = 3.8 \text{ V}$, $I_{OUT} = 5 \text{ mA}$, $0^\circ\text{C} \leq T_j \leq 125^\circ\text{C}$	—	0.3	—	$\text{mV}/^\circ\text{C}$

TA48L02F

Electrical Characteristics

($C_{IN} = 0.33 \mu\text{F}$, $C_{OUT} = 3.3 \mu\text{F}$, $T_j = 25^\circ\text{C}$, unless otherwise specified)

Characteristics	Symbol	Test Conditions	Min	Typ.	Max	Unit
Output voltage	V_{OUT}	$V_{IN} = 4.0 \text{ V}$, $I_{OUT} = 40 \text{ mA}$	1.94	2.0	2.06	V
		$3.0 \text{ V} \leq V_{IN} \leq 12 \text{ V}$, $5 \text{ mA} \leq I_{OUT} \leq 100 \text{ mA}$, $0^\circ\text{C} \leq T_j \leq 125^\circ\text{C}$	1.90	2.0	2.10	
Line regulation	Reg · line	$3.0 \text{ V} \leq V_{IN} \leq 12 \text{ V}$, $I_{OUT} = 40 \text{ mA}$	—	2	20	mV
Load regulation	Reg · load	$V_{IN} = 4.0 \text{ V}$, $5 \text{ mA} \leq I_{OUT} \leq 150 \text{ mA}$	—	18	40	mV
Quiescent current	I_B	$3.0 \text{ V} \leq V_{IN} \leq 12 \text{ V}$, $I_{OUT} = 0 \text{ A}$	—	0.4	0.8	mA
		$3.0 \text{ V} \leq V_{IN} \leq 12 \text{ V}$, $I_{OUT} = 100 \text{ mA}$	—	1	5	
Starting quiescent current	I_{Bstart}	$V_{IN} = 2.1 \text{ V}$, $I_{OUT} = 0 \text{ A}$	—	0.5	1.5	mA
		$V_{IN} = 2.1 \text{ V}$, $I_{OUT} = 100 \text{ mA}$	—	5	20	
Output noise voltage	V_{NO}	$V_{IN} = 4.0 \text{ V}$, $I_{OUT} = 40 \text{ mA}$, $10 \text{ Hz} \leq f \leq 100 \text{ kHz}$	—	55	—	μV_{rms}
Ripple rejection	R.R.	$3.0 \text{ V} \leq V_{IN} \leq 12 \text{ V}$, $I_{OUT} = 40 \text{ mA}$, $f = 120 \text{ Hz}$	52	70	—	dB
Dropout voltage	V_D	$I_{OUT} = 40 \text{ mA}$	—	0.2	0.35	V
		$I_{OUT} = 100 \text{ mA}$	—	0.3	0.5	
Average temperature coefficient of output voltage	T_{CVO}	$V_{IN} = 4.0 \text{ V}$, $I_{OUT} = 5 \text{ mA}$, $0^\circ\text{C} \leq T_j \leq 125^\circ\text{C}$	—	0.35	—	$\text{mV}/^\circ\text{C}$

TA48L025F

Electrical Characteristics

($C_{IN} = 0.33 \mu\text{F}$, $C_{OUT} = 3.3 \mu\text{F}$, $T_j = 25^\circ\text{C}$, unless otherwise specified)

Characteristics	Symbol	Test Conditions	Min	Typ.	Max	Unit
Output voltage	V_{OUT}	$V_{IN} = 4.5 \text{ V}$, $I_{OUT} = 40 \text{ mA}$	2.425	2.5	2.575	V
		$3.5 \text{ V} \leq V_{IN} \leq 12 \text{ V}$, $5 \text{ mA} \leq I_{OUT} \leq 100 \text{ mA}$, $0^\circ\text{C} \leq T_j \leq 125^\circ\text{C}$	2.375	2.5	2.625	
Line regulation	Reg · line	$3.5 \text{ V} \leq V_{IN} \leq 12 \text{ V}$, $I_{OUT} = 40 \text{ mA}$	—	2	20	mV
Load regulation	Reg · load	$V_{IN} = 4.5 \text{ V}$, $5 \text{ mA} \leq I_{OUT} \leq 150 \text{ mA}$	—	18	40	mV
Quiescent current	I_B	$3.5 \text{ V} \leq V_{IN} \leq 12 \text{ V}$, $I_{OUT} = 0 \text{ A}$	—	0.4	0.8	mA
		$3.5 \text{ V} \leq V_{IN} \leq 12 \text{ V}$, $I_{OUT} = 100 \text{ mA}$	—	1	5	
Starting quiescent current	I_{Bstart}	$V_{IN} = 2.4 \text{ V}$, $I_{OUT} = 0 \text{ A}$	—	0.5	1.5	mA
		$V_{IN} = 2.4 \text{ V}$, $I_{OUT} = 100 \text{ mA}$	—	7	20	
Output noise voltage	V_{NO}	$V_{IN} = 4.5 \text{ V}$, $I_{OUT} = 40 \text{ mA}$, $10 \text{ Hz} \leq f \leq 100 \text{ kHz}$	—	65	—	μV_{rms}
Ripple rejection	R.R.	$3.5 \text{ V} \leq V_{IN} \leq 12 \text{ V}$, $I_{OUT} = 40 \text{ mA}$, $f = 120 \text{ Hz}$	52	70	—	dB
Dropout voltage	V_D	$I_{OUT} = 40 \text{ mA}$	—	0.16	0.35	V
		$I_{OUT} = 100 \text{ mA}$	—	0.27	0.5	
Average temperature coefficient of output voltage	T_{CVO}	$V_{IN} = 4.5 \text{ V}$, $I_{OUT} = 5 \text{ mA}$, $0^\circ\text{C} \leq T_j \leq 125^\circ\text{C}$	—	0.45	—	$\text{mV}/^\circ\text{C}$

TA48L03F

Electrical Characteristics

($C_{IN} = 0.33 \mu\text{F}$, $C_{OUT} = 3.3 \mu\text{F}$, $T_j = 25^\circ\text{C}$, unless otherwise specified)

Characteristics	Symbol	Test Conditions	Min	Typ.	Max	Unit
Output voltage	V_{OUT}	$V_{IN} = 5.0 \text{ V}$, $I_{OUT} = 40 \text{ mA}$	2.91	3.0	3.09	V
		$4.0 \text{ V} \leq V_{IN} \leq 12 \text{ V}$, $5 \text{ mA} \leq I_{OUT} \leq 100 \text{ mA}$, $0^\circ\text{C} \leq T_j \leq 125^\circ\text{C}$	2.85	3.0	3.15	
Line regulation	Reg · line	$4.0 \text{ V} \leq V_{IN} \leq 12 \text{ V}$, $I_{OUT} = 40 \text{ mA}$	—	2	20	mV
Load regulation	Reg · load	$V_{IN} = 5.0 \text{ V}$, $5 \text{ mA} \leq I_{OUT} \leq 150 \text{ mA}$	—	18	40	mV
Quiescent current	I_B	$4.0 \text{ V} \leq V_{IN} \leq 12 \text{ V}$, $I_{OUT} = 0 \text{ A}$	—	0.4	0.8	mA
		$4.0 \text{ V} \leq V_{IN} \leq 12 \text{ V}$, $I_{OUT} = 100 \text{ mA}$	—	1	5	
Starting quiescent current	I_{Bstart}	$V_{IN} = 2.8 \text{ V}$, $I_{OUT} = 0 \text{ A}$	—	0.5	1.5	mA
		$V_{IN} = 2.8 \text{ V}$, $I_{OUT} = 100 \text{ mA}$	—	7	20	
Output noise voltage	V_{NO}	$V_{IN} = 5.0 \text{ V}$, $I_{OUT} = 40 \text{ mA}$, $10 \text{ Hz} \leq f \leq 100 \text{ kHz}$	—	80	—	μV_{rms}
Ripple rejection	R.R.	$4.0 \text{ V} \leq V_{IN} \leq 12 \text{ V}$, $I_{OUT} = 40 \text{ mA}$, $f = 120 \text{ Hz}$	50	68	—	dB
Dropout voltage	V_D	$I_{OUT} = 40 \text{ mA}$	—	0.16	0.35	V
		$I_{OUT} = 100 \text{ mA}$	—	0.27	0.5	
Average temperature coefficient of output voltage	T_{CVO}	$V_{IN} = 5 \text{ V}$, $I_{OUT} = 5 \text{ mA}$, $0^\circ\text{C} \leq T_j \leq 125^\circ\text{C}$	—	0.5	—	$\text{mV}/^\circ\text{C}$

TA48L033F

Electrical Characteristics

($C_{IN} = 0.33 \mu F$, $C_{OUT} = 3.3 \mu F$, $T_j = 25^\circ C$, unless otherwise specified)

Characteristics	Symbol	Test Conditions	Min	Typ.	Max	Unit
Output voltage	V_{OUT}	$V_{IN} = 5.3 V$, $I_{OUT} = 40 mA$	3.2	3.3	3.4	V
		$4.3 V \leq V_{IN} \leq 12 V$, $5 mA \leq I_{OUT} \leq 100 mA$, $0^\circ C \leq T_j \leq 125^\circ C$	3.135	3.3	3.465	
Line regulation	Reg · line	$4.3 V \leq V_{IN} \leq 12 V$, $I_{OUT} = 40 mA$	—	2	20	mV
Load regulation	Reg · load	$V_{IN} = 5.3 V$, $5 mA \leq I_{OUT} \leq 150 mA$	—	18	40	mV
Quiescent current	I_B	$4.3 V \leq V_{IN} \leq 12 V$, $I_{OUT} = 0 A$	—	0.4	0.8	mA
		$4.3 V \leq V_{IN} \leq 12 V$, $I_{OUT} = 100 mA$	—	1	5	
Starting quiescent current	I_{Bstart}	$V_{IN} = 3.0 V$, $I_{OUT} = 0 A$	—	0.5	1.5	mA
		$V_{IN} = 3.0 V$, $I_{OUT} = 100 mA$	—	7	20	
Output noise voltage	V_{NO}	$V_{IN} = 5.3 V$, $I_{OUT} = 40 mA$, $10 Hz \leq f \leq 100 kHz$	—	85	—	μV_{rms}
Ripple rejection	R.R.	$4.3 V \leq V_{IN} \leq 12 V$, $I_{OUT} = 40 mA$, $f = 120 Hz$	50	68	—	dB
Dropout voltage	V_D	$I_{OUT} = 40 mA$	—	0.16	0.35	V
		$I_{OUT} = 100 mA$	—	0.27	0.5	
Average temperature coefficient of output voltage	T_{CVO}	$V_{IN} = 5.3 V$, $I_{OUT} = 5 mA$, $0^\circ C \leq T_j \leq 125^\circ C$	—	0.55	—	$mV/^\circ C$

TA48L05F

Electrical Characteristics

($C_{IN} = 0.33 \mu F$, $C_{OUT} = 3.3 \mu F$, $T_j = 25^\circ C$, unless otherwise specified)

Characteristics	Symbol	Test Conditions	Min	Typ.	Max	Unit
Output voltage	V_{OUT}	$V_{IN} = 7.0 V$, $I_{OUT} = 40 mA$	4.85	5.0	5.15	V
		$6.0 V \leq V_{IN} \leq 12 V$, $5 mA \leq I_{OUT} \leq 100 mA$, $0^\circ C \leq T_j \leq 125^\circ C$	4.75	5.0	5.25	
Line regulation	Reg · line	$6.0 V \leq V_{IN} \leq 12 V$, $I_{OUT} = 40 mA$	—	2	20	mV
Load regulation	Reg · load	$V_{IN} = 7.0 V$, $5 mA \leq I_{OUT} \leq 150 mA$	—	18	45	mV
Quiescent current	I_B	$6.0 V \leq V_{IN} \leq 12 V$, $I_{OUT} = 0 A$	—	0.4	0.8	mA
		$6.0 V \leq V_{IN} \leq 12 V$, $I_{OUT} = 100 mA$	—	1	5	
Starting quiescent current	I_{Bstart}	$V_{IN} = 4.5 V$, $I_{OUT} = 0 A$	—	0.5	1.5	mA
		$V_{IN} = 4.5 V$, $I_{OUT} = 100 mA$	—	7	20	
Output noise voltage	V_{NO}	$V_{IN} = 7.0 V$, $I_{OUT} = 40 mA$, $10 Hz \leq f \leq 100 kHz$	—	135	—	μV_{rms}
Ripple rejection	R.R.	$6.0 V \leq V_{IN} \leq 12 V$, $I_{OUT} = 40 mA$, $f = 120 Hz$	50	64	—	dB
Dropout voltage	V_D	$I_{OUT} = 40 mA$	—	0.16	0.35	V
		$I_{OUT} = 100 mA$	—	0.27	0.5	
Average temperature coefficient of output voltage	T_{CVO}	$V_{IN} = 7.0 V$, $I_{OUT} = 5 mA$, $0^\circ C \leq T_j \leq 125^\circ C$	—	0.85	—	$mV/^\circ C$

Electrical Characteristics for All Products

Generally, the characteristics of power supply ICs change according to temperature fluctuations. The specification $T_j = 25^\circ\text{C}$ is based on a state where temperature increase has no effect (assuming no fluctuation in the characteristics) as ascertained by pulse tests.

Standard Application Circuit

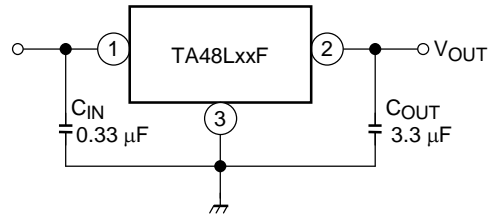

Connect the input terminal and GND, and the output terminal and GND, by capacitor respectively. The capacitances should be determined experimentally. In particular, adequate investigation should be made so that there is no problem even at time of high or low temperature.

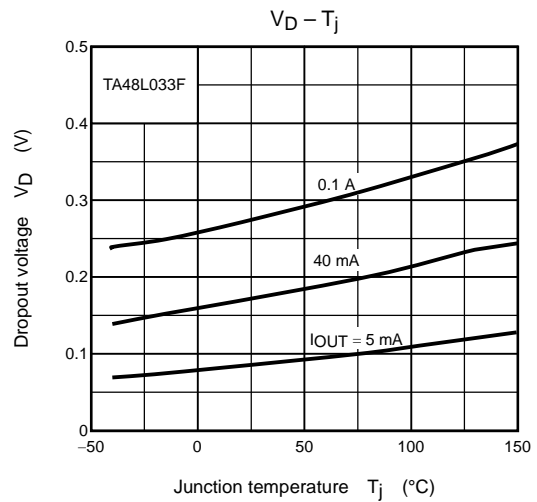
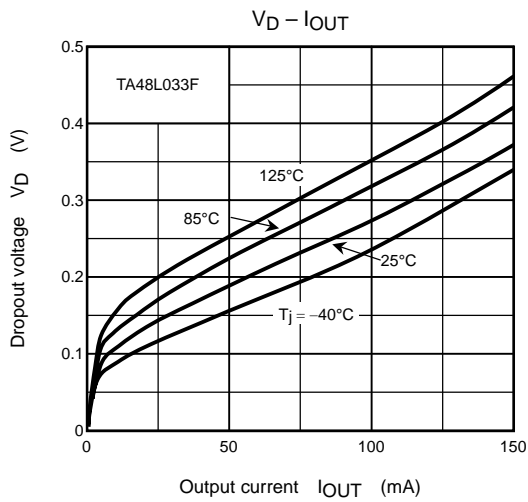
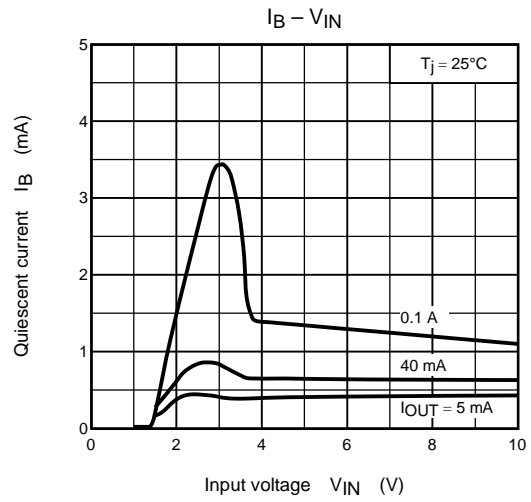
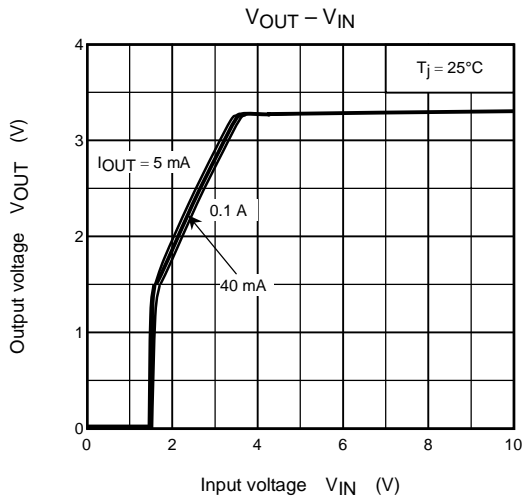
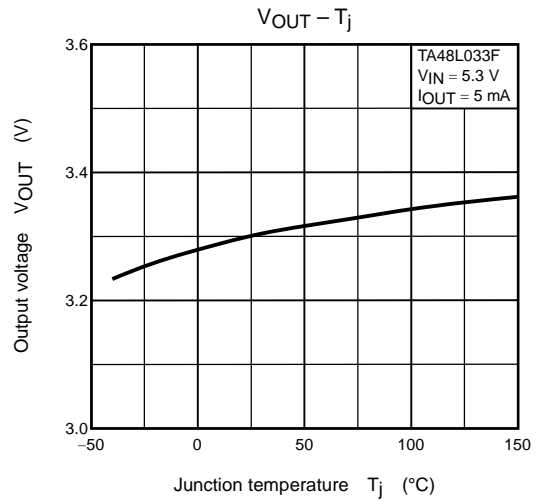
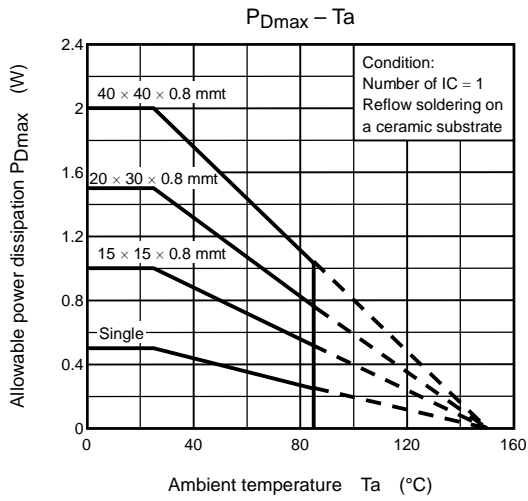

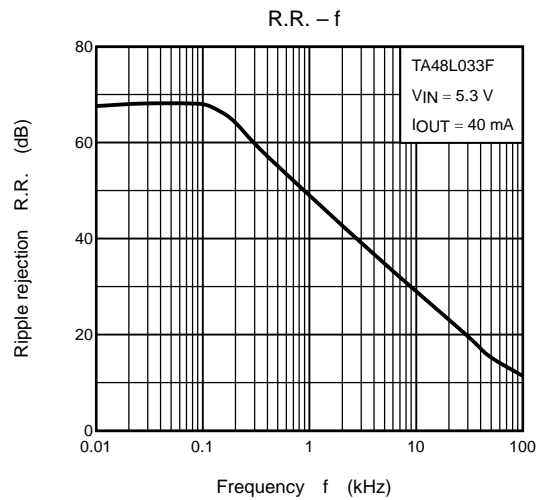
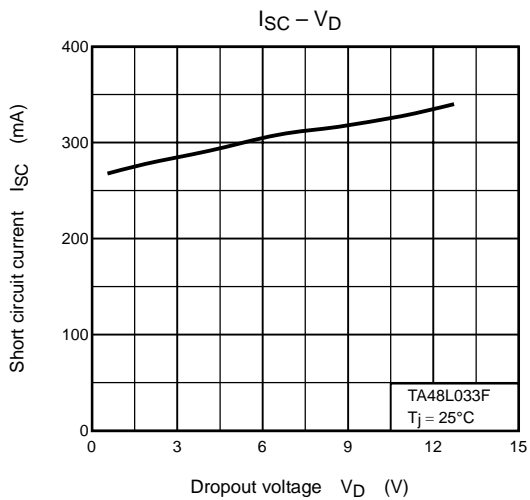
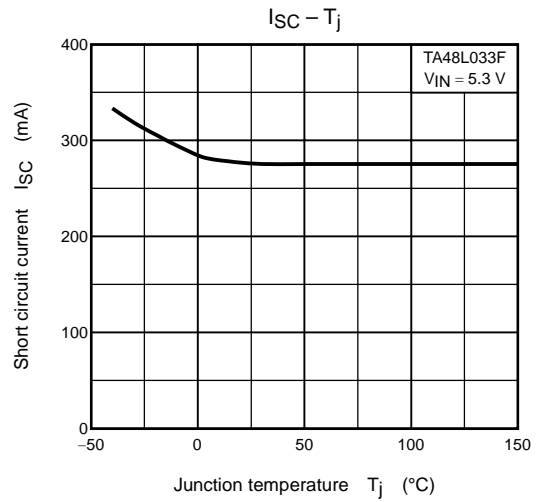
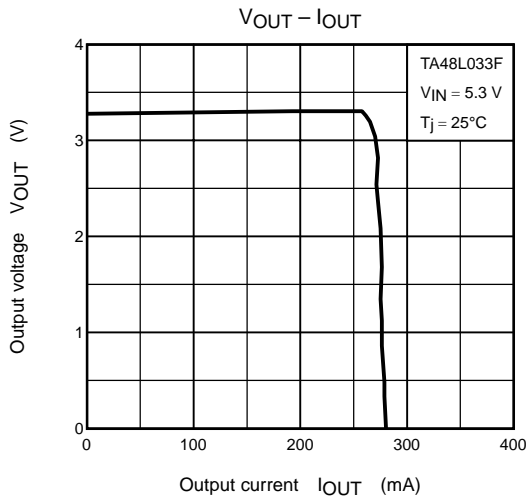
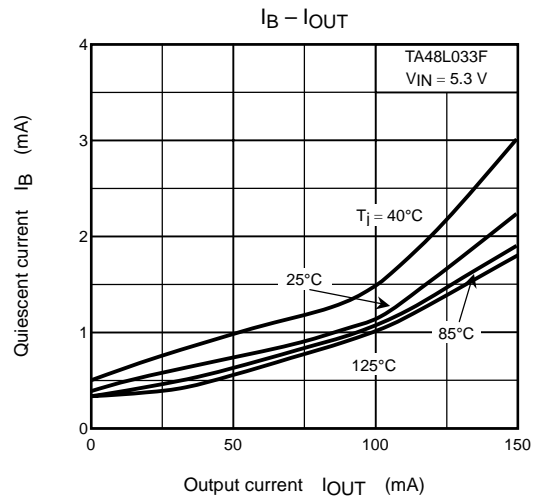
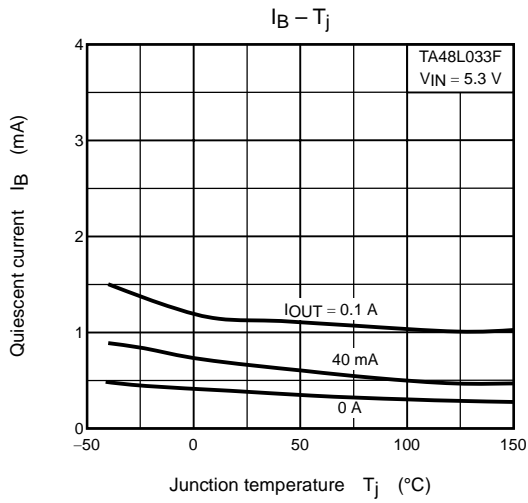

Package Dimensions

HSOP3-P-1.50

Unit : mm

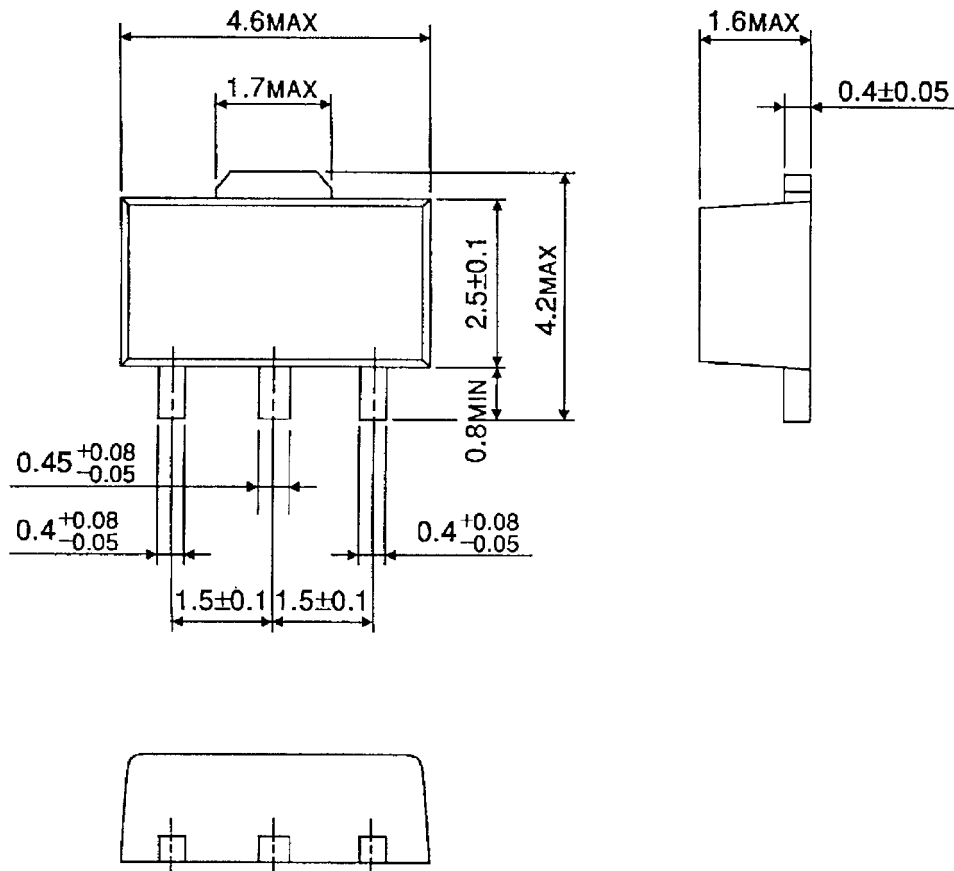

Weight: 0.05 g (typ.)

RESTRICTIONS ON PRODUCT USE

000707EBA

- TOSHIBA is continually working to improve the quality and reliability of its products. Nevertheless, semiconductor devices in general can malfunction or fail due to their inherent electrical sensitivity and vulnerability to physical stress. It is the responsibility of the buyer, when utilizing TOSHIBA products, to comply with the standards of safety in making a safe design for the entire system, and to avoid situations in which a malfunction or failure of such TOSHIBA products could cause loss of human life, bodily injury or damage to property.
In developing your designs, please ensure that TOSHIBA products are used within specified operating ranges as set forth in the most recent TOSHIBA products specifications. Also, please keep in mind the precautions and conditions set forth in the "Handling Guide for Semiconductor Devices," or "TOSHIBA Semiconductor Reliability Handbook" etc..
- The TOSHIBA products listed in this document are intended for usage in general electronics applications (computer, personal equipment, office equipment, measuring equipment, industrial robotics, domestic appliances, etc.). These TOSHIBA products are neither intended nor warranted for usage in equipment that requires extraordinarily high quality and/or reliability or a malfunction or failure of which may cause loss of human life or bodily injury ("Unintended Usage"). Unintended Usage include atomic energy control instruments, airplane or spaceship instruments, transportation instruments, traffic signal instruments, combustion control instruments, medical instruments, all types of safety devices, etc.. Unintended Usage of TOSHIBA products listed in this document shall be made at the customer's own risk.
- The products described in this document are subject to the foreign exchange and foreign trade laws.
- The information contained herein is presented only as a guide for the applications of our products. No responsibility is assumed by TOSHIBA CORPORATION for any infringements of intellectual property or other rights of the third parties which may result from its use. No license is granted by implication or otherwise under any intellectual property or other rights of TOSHIBA CORPORATION or others.
- The information contained herein is subject to change without notice.