

# EL13C5C2F-100.000M

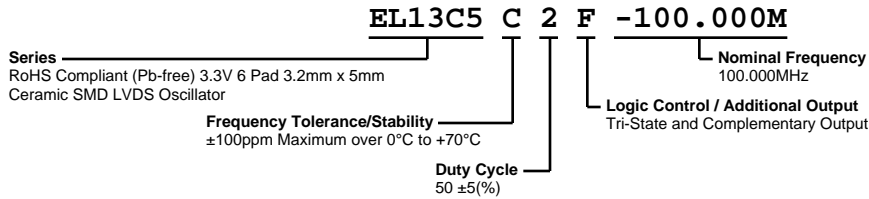

## ELECTRICAL SPECIFICATIONS

Nominal Frequency	100.000MHz
Frequency Tolerance/Stability	±100ppm Maximum over 0°C to +70°C (Inclusive of all conditions: Calibration Tolerance (at 25°C), Frequency Stability over the Operating Temperature Range, Supply Voltage Change, Output Load Change, First Year Aging at 25°C, Shock, and Vibration)
Supply Voltage	+3.3Vdc ±5%
Input Current	66mA Maximum
Output Voltage Logic High (Voh)	1.43Vdc Typical, 1.6Vdc Maximum
Output Voltage Logic Low (Vol)	1.1Vdc Typical, 0.9Vdc Minimum
Differential Output Voltage (Vod)	247mV Minimum, 330mV Typical, 454mV Maximum
Offset Voltage (Vos)	1.125V Minimum, 1.250V Typical, 1.375V Maximum
Rise/Fall Time	300pSec Typical, 700pSec Maximum (Measured over 20% to 80% of waveform)
Differential Output Error (dVod)	50mV Maximum
Duty Cycle	50 ±5(%) (Measured at 50% of waveform or at the crossing point)
Offset Error (dVos)	150mV Maximum
Output Swing (dVOpp)	350mVdc Minimum
Load Drive Capability	100 Ohms Between Output and Complementary Output
Output Logic Type	LVDS
Phase Noise	-60dBc/Hz at 10Hz Offset, -95dBc/Hz at 100Hz Offset, -125dBc/Hz at 1kHz Offset, -143dBc/Hz at 10kHz Offset, -145dBc/Hz at 100kHz Offset, -145dBc/Hz at 1MHz Offset, -146dBc/Hz at 10MHz Offset (All Values are Typical, Fo=156.250MHz)
Logic Control / Additional Output	Tri-State and Complementary Output
Tri-State Input Voltage (Vih and Vil)	Vih of 70% of Vcc Minimum or No Connect to Enable Output and Complementary Output, Vil of 30% of Vcc Maximum to Disable High Impedance Output and Complementary Output
Standby Current	30µA Maximum (Without Load)
RMS Phase Jitter	0.4pSec Typical, 1pSec Maximum (Fj=12kHz to 20MHz)
Start Up Time	10mSec Maximum
Storage Temperature Range	-55°C to +125°C

## ENVIRONMENTAL & MECHANICAL SPECIFICATIONS

ESD Susceptibility	MIL-STD-883, Method 3015, Class 1, HBM: 1500V
Fine Leak Test	MIL-STD-883, Method 1014, Condition A
Flammability	UL94-V0
Gross Leak Test	MIL-STD-883, Method 1014, Condition C
Mechanical Shock	MIL-STD-883, Method 2002, Condition B
Moisture Resistance	MIL-STD-883, Method 1004
Moisture Sensitivity	J-STD-020, MSL 1
Resistance to Soldering Heat	MIL-STD-202, Method 210, Condition K
Resistance to Solvents	MIL-STD-202, Method 215
Solderability	MIL-STD-883, Method 2003
Temperature Cycling	MIL-STD-883, Method 1010, Condition B
Vibration	MIL-STD-883, Method 2007, Condition A

# EL13C5C2F-100.000M

## MECHANICAL DIMENSIONS (all dimensions in millimeters)

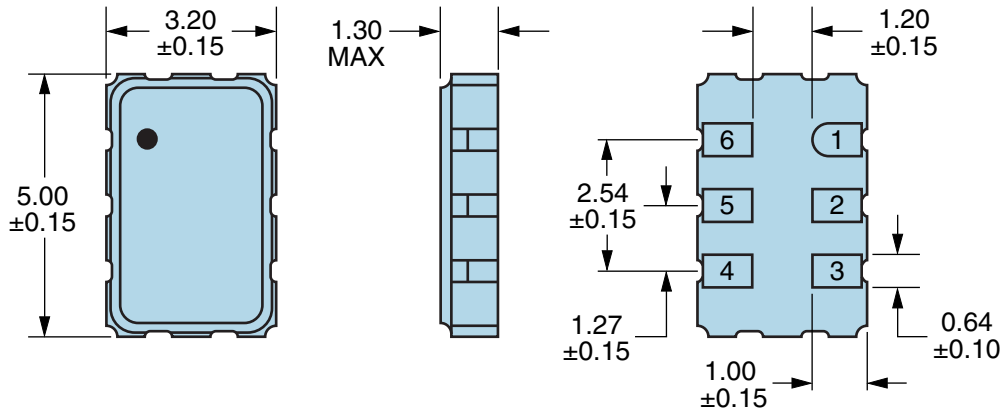

PIN	CONNECTION
1	Tri-State
2	No Connect
3	Case/Ground
4	Output
5	Complementary Output
6	Supply Voltage

LINE	MARKING
1	<b>E100.00</b> <i>E=Ecliptek Designator</i>
2	<b>XXYYZZ</b> <i>XX=Ecliptek Manufacturing Code</i> <i>Y=Last Digit of the Year</i> <i>ZZ=Week of the Year</i>

## Suggested Solder Pad Layout

All Dimensions in Millimeters

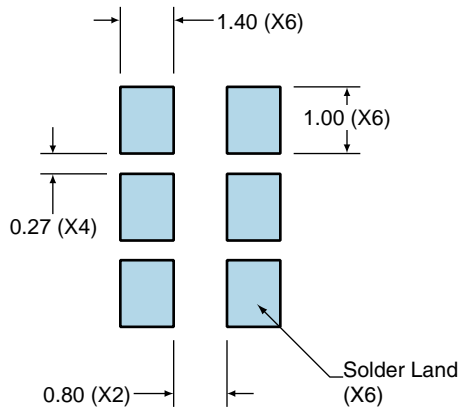

All Tolerances are ±0.1

# EL13C5C2F-100.000M

## OUTPUT WAVEFORM & TIMING DIAGRAM

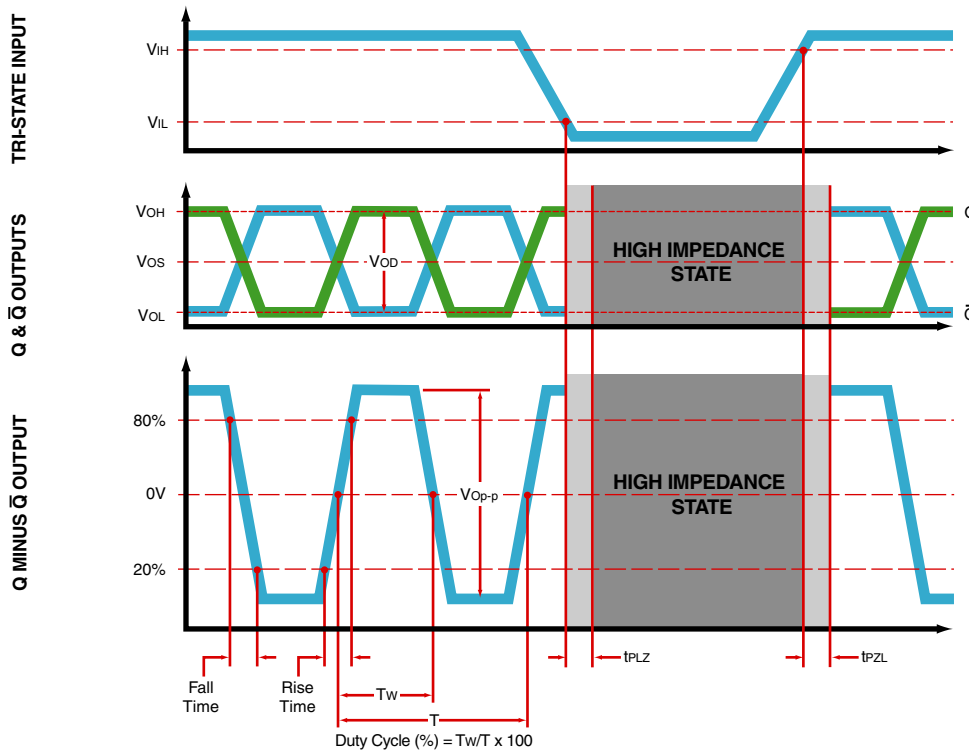

## Test Circuit for Tri-State and Complementary Output

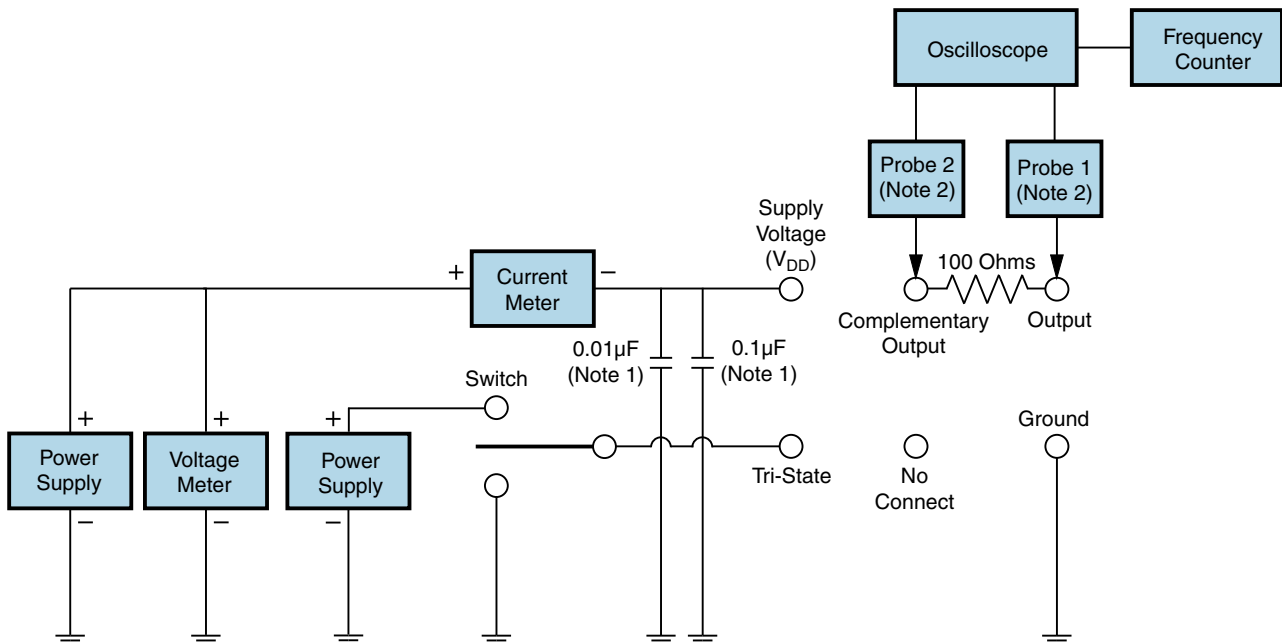

Note 1: An external  $0.01\mu F$  ceramic bypass capacitor in parallel with a  $0.1\mu F$  high frequency ceramic bypass capacitor close (less than 2mm) to the package ground and supply voltage pin is required.

Note 2: A low capacitance ( $<12pF$ ), 10X attenuation factor, high impedance ( $>10M\Omega$ ), and high bandwidth ( $>500MHz$ ) passive probe is recommended.

Note 3: Test circuit PCB traces need to be designed for a characteristic line impedance of 50 ohms.

## Recommended Solder Reflow Methods



### High Temperature Infrared/Convection

<b><math>T_s</math> MAX to <math>T_L</math> (Ramp-up Rate)</b>	3°C/second Maximum
<b>Preheat</b>	
- Temperature Minimum ( $T_s$ MIN)	150°C
- Temperature Typical ( $T_s$ TYP)	175°C
- Temperature Maximum ( $T_s$ MAX)	200°C
- Time ( $t_s$ MIN)	60 - 180 Seconds
<b>Ramp-up Rate (<math>T_L</math> to <math>T_p</math>)</b>	3°C/second Maximum
<b>Time Maintained Above:</b>	
- Temperature ( $T_L$ )	217°C
- Time ( $t_L$ )	60 - 150 Seconds
<b>Peak Temperature (<math>T_p</math>)</b>	260°C Maximum for 10 Seconds Maximum
<b>Target Peak Temperature (<math>T_p</math> Target)</b>	250°C +0/-5°C
<b>Time within 5°C of actual peak (<math>t_p</math>)</b>	20 - 40 seconds
<b>Ramp-down Rate</b>	6°C/second Maximum
<b>Time 25°C to Peak Temperature (t)</b>	8 minutes Maximum
<b>Moisture Sensitivity Level</b>	Level 1

## Recommended Solder Reflow Methods



### Low Temperature Infrared/Convection 240°C

<b><math>T_S</math> MAX to <math>T_L</math> (Ramp-up Rate)</b>	5°C/second Maximum
<b>Preheat</b>	
- Temperature Minimum ( $T_S$ MIN)	N/A
- Temperature Typical ( $T_S$ TYP)	150°C
- Temperature Maximum ( $T_S$ MAX)	N/A
- Time ( $t_S$ MIN)	60 - 120 Seconds
<b>Ramp-up Rate (<math>T_L</math> to <math>T_P</math>)</b>	5°C/second Maximum
<b>Time Maintained Above:</b>	
- Temperature ( $T_L$ )	150°C
- Time ( $t_L$ )	200 Seconds Maximum
<b>Peak Temperature (<math>T_P</math>)</b>	240°C Maximum
<b>Target Peak Temperature (<math>T_P</math> Target)</b>	240°C Maximum 1 Time / 230°C Maximum 2 Times
<b>Time within 5°C of actual peak (<math>t_p</math>)</b>	10 seconds Maximum 2 Times / 80 seconds Maximum 1 Time
<b>Ramp-down Rate</b>	5°C/second Maximum
<b>Time 25°C to Peak Temperature (t)</b>	N/A
<b>Moisture Sensitivity Level</b>	Level 1

### Low Temperature Manual Soldering

185°C Maximum for 10 seconds Maximum, 2 times Maximum.

### High Temperature Manual Soldering

260°C Maximum for 5 seconds Maximum, 2 times Maximum.