



# 3.0V/3.3V Adjustable Microprocessor Supervisory Circuits

## General Description

The MAX793/MAX794/MAX795 microprocessor ( $\mu$ P) supervisory circuits monitor and control the activities of +3.0V/+3.3V  $\mu$ Ps by providing backup-battery switchover, among other features such as low-line indication,  $\mu$ P reset, write protection for CMOS RAM, and a watchdog (see the *Selector Guide* below). The backup-battery voltage can exceed  $V_{CC}$ , permitting the use of 3.6V lithium batteries in systems using 3.0V to 3.3V for  $V_{CC}$ .

The MAX793/MAX795 offer a choice of reset threshold voltage range (denoted by suffix letter): 3.00V to 3.15V (T), 2.85V to 3.00V (S), and 2.55V to 2.70V (R). The MAX794's reset threshold is set externally with a resistor divider. The MAX793/MAX794 are available in 16-pin DIP and narrow SO packages, and the MAX795 comes in 8-pin DIP and SO packages.

## Selector Guide

FEATURE	MAX793	MAX794	MAX795
Active-Low Reset	✓	✓	✓
Active-High Reset	✓	✓	
Programmable Reset Threshold		✓	
Low-Line Early Warning Output	✓	✓	
Backup-Battery Switchover	✓	✓	✓
External Switch Driver	✓	✓	✓
Power-Fail Comparator	✓	✓	
Battery OK Output	✓		
Watchdog Input	✓	✓	
Battery Freshness Seal	✓	✓	
Manual Reset Input	✓	✓	
Chip-Enable Gating	✓	✓	✓
Pins-Package	16-DIP/SO	16-DIP/SO	8-DIP/SO

## Applications

Battery-Powered Computers and Controllers  
 Embedded Controllers  
 Intelligent Controllers  
 Critical  $\mu$ P Power Monitoring  
 Portable Equipment

Pin Configurations appear at end of data sheet.

## Features

### MAX793/MAX794/MAX795

- ◆ Precision Supply-Voltage Monitor:
  - Fixed Reset Trip Voltage (MAX793/MAX795)
  - Adjustable Reset Trip Voltage (MAX794)
- ◆ Guaranteed Reset Assertion to  $V_{CC} = 1V$
- ◆ Backup-Battery Power Switching—Battery Voltage Can Exceed  $V_{CC}$
- ◆ On-Board Gating of Chip-Enable Signals—7ns Max Propagation Delay

### MAX793/MAX794 Only

- ◆ Battery Freshness Seal
- ◆ Battery OK Output (MAX793)
- ◆ Uncommitted Voltage Monitor for Power-Fail or Low-Battery Warning
- ◆ Independent Watchdog Timer (1.6s timeout)
- ◆ Manual Reset Input

## Ordering Information

PART*	TEMP RANGE	PIN-PACKAGE
MAX793_CPE	0°C to +70°C	16 Plastic DIP
MAX793_CSE	0°C to +70°C	16 Narrow SO
MAX793_EPE	-40°C to +85°C	16 Plastic DIP
MAX793_ESE	-40°C to +85°C	16 Narrow SO

Ordering Information continued on last page.

\*The MAX793/MAX795 offer a choice of reset threshold voltage. Select the letter corresponding to the desired reset threshold voltage range (T = 3.00V to 3.15V, S = 2.85V to 3.00V, R = 2.55V to 2.70V) and insert it into the blank to complete the part number. The MAX794's reset threshold is adjustable.

Devices are available in both leaded and lead-free packaging. Specify lead free by adding the + symbol at the end of the part number when ordering.

## Typical Operating Circuit

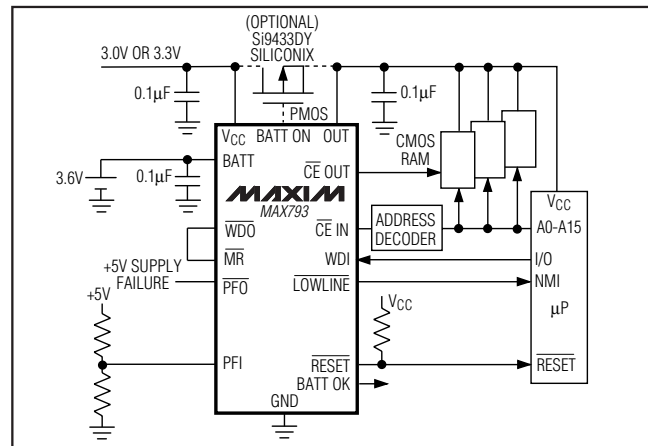

# 3.0V/3.3V Adjustable Microprocessor Supervisory Circuits

## ABSOLUTE MAXIMUM RATINGS

Terminal Voltage (with respect to GND)	
V <sub>CC</sub> .....	-0.3V to 6.0V
V <sub>BATT</sub> .....	-0.3V to 6.0V
All Other Inputs .....	-0.3V to the higher of V <sub>CC</sub> or V <sub>BATT</sub>
Continuous Input Current	
V <sub>CC</sub> .....	200mA
V <sub>BATT</sub> .....	50mA
GND .....	20mA
Output Current	
V <sub>OUT</sub> .....	200mA
All Other Outputs .....	20mA

Continuous Power Dissipation (T <sub>A</sub> = +70°C)	
8-Pin Plastic DIP (derate 9.09mW/°C above +70°C) .....	727mW
8-Pin SO (derate 5.88mW/°C above +70°C) .....	471mW
16-Pin Plastic DIP (derate 10.53mW/°C above +70°C) .....	842mW
16-Pin Narrow SO (derate 9.52mW/°C above +70°C) .....	696mW
Operating Temperature Ranges	
MAX793_C_/MAX794C_/MAX795_C_ .....	0°C to +70°C
MAX793_E_/MAX794E_/MAX795_E_ .....	-40°C to +85°C
Storage Temperature Range .....	-65°C to +160°C
Lead Temperature (soldering, 10s) .....	+300°C

Stresses beyond those listed under "Absolute Maximum Ratings" may cause permanent damage to the device. These are stress ratings only, and functional operation of the device at these or any other conditions beyond those indicated in the operational sections of the specifications is not implied. Exposure to absolute maximum rating conditions for extended periods may affect device reliability.

## ELECTRICAL CHARACTERISTICS

(V<sub>CC</sub> = 3.17V to 5.5V for the MAX793T/MAX795T, V<sub>CC</sub> = 3.02V to 5.5V for the MAX793S/MAX795S, V<sub>CC</sub> = 2.72V to 5.5V for the MAX793R/MAX794/MAX795R, V<sub>BATT</sub> = 3.6V, T<sub>A</sub> = T<sub>MIN</sub> to T<sub>MAX</sub>, unless otherwise noted. Typical values are at T<sub>A</sub> = +25°C.)

PARAMETER	SYMBOL	CONDITIONS	MIN	TYP	MAX	UNITS
Operating Voltage Range, V <sub>CC</sub> , V <sub>BATT</sub> (Note 1)		MAX79_C	1.0		5.5	V
		MAX79_E	1.1		5.5	
V <sub>CC</sub> Supply Current (excluding I <sub>OUT</sub> , I <sub>CE</sub> OUT)	I <sub>SUPPLY</sub>	MAX793/MAX794, M <sub>R</sub> = V <sub>CC</sub>	V <sub>CC</sub> < 3.6V	46	60	μA
			V <sub>CC</sub> < 5.5V	62	80	
		MAX795	V <sub>CC</sub> < 3.6V	35	50	
			V <sub>CC</sub> < 5.5V	49	70	
V <sub>CC</sub> Supply Current in Battery-Backup Mode (excluding I <sub>OUT</sub> )	I <sub>SUPPLY</sub>	V <sub>CC</sub> = 2.1V, V <sub>BATT</sub> = 2.3V	MAX793/MAX794	32	45	μA
			MAX795	24	35	
BATT Supply Current (excluding I <sub>OUT</sub> ) (Note 2)					1	μA
BATT Leakage Current, Freshness Seal Enabled		V <sub>CC</sub> = 0V, V <sub>OUT</sub> = 0V			1	μA
Battery Leakage Current (Note 3)					0.5	μA
OUT Output Voltage in Normal Mode	V <sub>OUT</sub>	I <sub>OUT</sub> = 75mA	V <sub>CC</sub> - 0.3	V <sub>CC</sub> - 0.125		V
		I <sub>OUT</sub> = 30mA (Note 4)	V <sub>CC</sub> - 0.12	V <sub>CC</sub> - 0.050		
		I <sub>OUT</sub> = 250μA (Note 4)	V <sub>CC</sub> - 0.001	V <sub>CC</sub> - 0.5mV		
OUT Output Voltage in Battery-Backup Mode	V <sub>OUT</sub>	V <sub>BATT</sub> = 2.3V	I <sub>OUT</sub> = 250μA	V <sub>BATT</sub> - 0.1	V <sub>BATT</sub> - 0.034	V
			I <sub>OUT</sub> = 1mA		V <sub>BATT</sub> - 0.14	
Battery Switch Threshold (V <sub>CC</sub> falling)	V <sub>CC</sub> - V <sub>BATT</sub>	V <sub>SW</sub> > V <sub>CC</sub> > 1.75V (Note 5)		20	65	mV
		V <sub>SW</sub>	V <sub>BATT</sub> > V <sub>CC</sub> (Note 6)	MAX793T/MAX795T	2.69	
	MAX793S/MAX795S			2.55	2.68	2.80
	MAX793R/MAX795R/MAX794			2.30	2.41	2.52
Battery Switch Threshold (V <sub>CC</sub> rising) (Note 7)	V <sub>CC</sub> - V <sub>BATT</sub>	This value is identical to the reset threshold, V <sub>CC</sub> rising for V <sub>BATT</sub> > V <sub>RST</sub>				mV
		V <sub>BATT</sub> < V <sub>RST</sub>		25	65	

# 3.0V/3.3V Adjustable Microprocessor Supervisory Circuits

MAX793/MAX794/MAX795

## ELECTRICAL CHARACTERISTICS (continued)

(V<sub>CC</sub> = 3.17V to 5.5V for the MAX793T/MAX795T, V<sub>CC</sub> = 3.02V to 5.5V for the MAX793S/MAX795S, V<sub>CC</sub> = 2.72V to 5.5V for the MAX793R/MAX794/MAX795R, V<sub>BATT</sub> = 3.6V, T<sub>A</sub> = T<sub>MIN</sub> to T<sub>MAX</sub>, unless otherwise noted. Typical values are at T<sub>A</sub> = +25°C.)

PARAMETER	SYMBOL	CONDITIONS	MIN	TYP	MAX	UNITS	
Reset Threshold (Note 8)	V <sub>RST</sub>	V <sub>CC</sub> Falling	MAX793T/MAX795T	3.00	3.075	3.15	V
			MAX793S/MAX795S	2.85	2.925	3.00	
			MAX793R/MAX795R	2.55	2.625	2.70	
		V <sub>CC</sub> Rising	MAX793T/MAX795T	3.00	3.085	3.17	
			MAX793S/MAX795S	2.85	2.935	3.02	
			MAX793R/MAX795R	2.55	2.635	2.72	
RESET IN Threshold (MAX794 only)	V <sub>RST IN</sub>	V <sub>CC</sub> Falling	1.212	1.240	1.262	V	
		V <sub>CC</sub> Rising	1.212	1.250	1.282		
RESET IN Leakage Current (MAX794 only)			-25	2	25	nA	
Reset Timeout Period	t <sub>RP</sub>	V <sub>CC</sub> < 3.6V	140	200	280	ms	
LOWLINE-to-Reset Threshold, (V <sub>LOWLINE</sub> - V <sub>RST</sub> ), V <sub>CC</sub> Falling	V <sub>LR</sub>	MAX793	30	45	60	mV	
		MAX794	5	15	25		
Low-Line Comparator Hysteresis		MAX793		10		mV	
		MAX794		10		mV	
LOWLINE Threshold, V <sub>CC</sub> Rising	V <sub>LL</sub>	MAX793T/MAX795T			3.23	V	
		MAX793S/MAX795S			3.08		
		MAX793R/MAX795R			2.78		
		MAX794			1.317		
PFI Input Threshold	V <sub>TH</sub>	V <sub>PFI</sub> falling	1.212	1.240	1.262	V	
		V <sub>PFI</sub> rising	1.212	1.250	1.287		
PFI Input Current			-25	2	25	nA	
PFI Hysteresis, PFI Rising				10	20	mV	
BATT OK Threshold (MAX793)	V <sub>BOK</sub>		2.00	2.25	2.50	V	
<b>INPUT AND OUTPUT LEVELS</b>							
RESET Output Voltage High	V <sub>OH</sub>	I <sub>SOURCE</sub> = 300μA, V <sub>CC</sub> = V <sub>RST</sub> min	0.8V <sub>CC</sub>	0.86V <sub>CC</sub>		V	
BATT OK, BATT ON, $\overline{WDO}$ , LOWLINE Output Voltage High	V <sub>OH</sub>	I <sub>SOURCE</sub> = 300μA, V <sub>CC</sub> = V <sub>RST</sub> max	0.8V <sub>CC</sub>	0.86V <sub>CC</sub>		V	
$\overline{PFO}$ Output Voltage High	V <sub>OH</sub>	I <sub>SOURCE</sub> = 65μA, V <sub>CC</sub> = V <sub>RST</sub> max	0.8V <sub>CC</sub>			V	
BATT ON Output Voltage High	V <sub>OH</sub>	I <sub>SOURCE</sub> = 100μA, V <sub>CC</sub> = 2.3V, V <sub>BATT</sub> = 3V	0.8V <sub>BATT</sub>			V	
RESET Output Leakage Current (Note 9)	I <sub>LEAK</sub>	V <sub>CC</sub> = V <sub>RST</sub> max	-1		-1	μA	
$\overline{PFO}$ Output Short to GND Current	I <sub>SC</sub>	V <sub>CC</sub> = 3.3V, V <sub><math>\overline{PFO}</math></sub> = 0V		180	500	μA	
$\overline{PFO}$ , $\overline{RESET}$ , $\overline{RESET}$ , $\overline{WDO}$ , LOWLINE Output Voltage Low	V <sub>OL</sub>	I <sub>SINK</sub> = 1.2mA; $\overline{RESET}$ , $\overline{LOWLINE}$ tested with V <sub>CC</sub> = V <sub>RST</sub> min; $\overline{RESET}$ , BATTOK, $\overline{WDO}$ tested with V <sub>CC</sub> = V <sub>RST</sub> max		0.08	0.2V <sub>CC</sub>	V	

## 3.0V/3.3V Adjustable Microprocessor Supervisory Circuits

### ELECTRICAL CHARACTERISTICS (continued)

(V<sub>CC</sub> = 3.17V to 5.5V for the MAX793T/MAX795T, V<sub>CC</sub> = 3.02V to 5.5V for the MAX793S/MAX795S, V<sub>CC</sub> = 2.72V to 5.5V for the MAX793R/MAX794/MAX795R, V<sub>BATT</sub> = 3.6V, T<sub>A</sub> = T<sub>MIN</sub> to T<sub>MAX</sub>, unless otherwise noted. Typical values are at T<sub>A</sub> = +25°C.)

PARAMETER	SYMBOL	CONDITIONS	MIN	TYP	MAX	UNITS
$\overline{\text{RESET}}$ Output Voltage Low	V <sub>OL</sub>	MAX79_C, V <sub>BATT</sub> = V <sub>CC</sub> = 1.0V, I <sub>SINK</sub> = 40μA		0.13	0.3	V
		MAX79_E, V <sub>BATT</sub> = V <sub>CC</sub> = 1.2V, I <sub>SINK</sub> = 200μA		0.17	0.3	
BATT ON Output Voltage Low	V <sub>OL</sub>	I <sub>SINK</sub> = 3.2mA, V <sub>CC</sub> = V <sub>RST</sub> max			0.2V <sub>CC</sub>	V
All Inputs Including $\overline{\text{PFO}}$ (Note 10)	V <sub>IH</sub>	V <sub>RST</sub> max < V <sub>CC</sub> < 5.5V			0.7V <sub>CC</sub>	V
	V <sub>IL</sub>		0.3V <sub>CC</sub>			
<b>MANUAL RESET INPUT</b>						
$\overline{\text{MR}}$ Pulse Width	t <sub>MR</sub>	MAX793/MAX794 only	100			ns
$\overline{\text{MR}}$ -to-Reset Delay	t <sub>MD</sub>	MAX793/MAX794 only		75	250	ns
$\overline{\text{MR}}$ Pullup Current		MAX793/MAX794 only, $\overline{\text{MR}} = 0\text{V}$	25	70	250	μA
<b>CHIP-ENABLE GATING</b>						
$\overline{\text{CE}}$ IN Leakage Current	I <sub>LEAK</sub>	Disable mode		±10		nA
$\overline{\text{CE}}$ IN-to- $\overline{\text{CE}}$ OUT Resistance		Enable mode, V <sub>CC</sub> = V <sub>RST</sub> max		46		Ω
$\overline{\text{CE}}$ IN-to- $\overline{\text{CE}}$ OUT Propagation Delay		V <sub>CC</sub> = V <sub>RST</sub> max, Figure 9		2	7	ns
$\overline{\text{CE}}$ OUT Drive from $\overline{\text{CE}}$ IN	V <sub>OH</sub>	V <sub>CC</sub> = V <sub>RST</sub> max, I <sub>OUT</sub> = -1mA, V <sub><math>\overline{\text{CE}}</math> IN</sub> = V <sub>CC</sub>	0.8V <sub>CC</sub>			V
	V <sub>OL</sub>	V <sub>CC</sub> = V <sub>RST</sub> max, I <sub>OUT</sub> = 1.6mA, V <sub><math>\overline{\text{CE}}</math> IN</sub> = 0V			0.2V <sub>CC</sub>	
Reset to $\overline{\text{CE}}$ OUT High Delay				10		μs
$\overline{\text{CE}}$ OUT Output Voltage High (reset active)	V <sub>OH</sub>	I <sub>OH</sub> = 500μA, V <sub>CC</sub> < 2.3V	0.8V <sub>BATT</sub>			V
<b>WATCHDOG (MAX793/MAX794 only)</b>						
WDI Input Current		0V < V <sub>CC</sub> < 5.5V	-1	0.01	1	μA
Watchdog Timeout Period	t <sub>WD</sub>		1.00	1.60	2.25	sec
WDI Pulse Width			1.00			ns

**Note 1:** V<sub>CC</sub> supply current, logic input leakage, watchdog functionality (MAX793/MAX794),  $\overline{\text{MR}}$  functionality (MAX793/MAX794), PFI functionality (MAX793/MAX794), and state of  $\overline{\text{RESET}}$  and RESET (MAX793/MAX794) tested at V<sub>BATT</sub> = 3.6V and V<sub>CC</sub> = 5.5V. The state of  $\overline{\text{RESET}}$  is tested at V<sub>CC</sub> = V<sub>CC</sub> min.

**Note 2:** Tested at V<sub>BATT</sub> = 3.6V, V<sub>CC</sub> = 3.5V and 0V. The battery current rises to 10μA over a narrow transition window around V<sub>CC</sub> = 1.9V.

**Note 3:** Leakage current into the battery is tested under the worst-case conditions at V<sub>CC</sub> = 5.5V, V<sub>BATT</sub> = 1.8V and V<sub>CC</sub> = 1.5V, V<sub>BATT</sub> = 1.0V.

**Note 4:** Guaranteed by design.

**Note 5:** When V<sub>SW</sub> > V<sub>CC</sub> > V<sub>BATT</sub>, OUT remains connected to V<sub>CC</sub> until V<sub>CC</sub> drops below V<sub>BATT</sub>. The V<sub>CC</sub>-to-V<sub>BATT</sub> comparator has a small 15mV typical hysteresis to prevent oscillation. For V<sub>CC</sub> < 1.75V (typical), OUT switches to BATT regardless of V<sub>BATT</sub>.

**Note 6:** When V<sub>BATT</sub> > V<sub>CC</sub> > V<sub>SW</sub>, OUT remains connected to V<sub>CC</sub> until V<sub>CC</sub> drops below the battery switch threshold (V<sub>SW</sub>).

**Note 7:** OUT switches from BATT to V<sub>CC</sub> when V<sub>CC</sub> rises above the reset threshold, if V<sub>BATT</sub> > V<sub>RST</sub>. In this case, switchover back to V<sub>CC</sub> occurs at the exact voltage that causes reset to be asserted, however, switchover occurs 200ms prior to reset. If V<sub>BATT</sub> < V<sub>RST</sub>, OUT switches from BATT to V<sub>CC</sub> when V<sub>CC</sub> exceeds V<sub>BATT</sub>.

**Note 8:** The reset threshold tolerance is wider for V<sub>CC</sub> rising than for V<sub>CC</sub> falling to accommodate the 10mV typical hysteresis, which prevents internal oscillation.

**Note 9:** The leakage current into or out of the  $\overline{\text{RESET}}$  pin is tested with  $\overline{\text{RESET}}$  not asserted ( $\overline{\text{RESET}}$  output high impedance).

**Note 10:** PFO is normally an output, but is used as an input when activating the battery freshness seal.

# 3.0V/3.3V/Adjustable Microprocessor Supervisory Circuits

## Typical Operating Characteristics

( $T_A = +25^\circ\text{C}$ , unless otherwise noted.)

MAX793/MAX794/MAX795

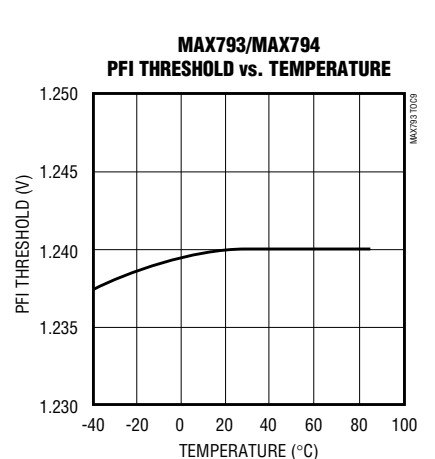
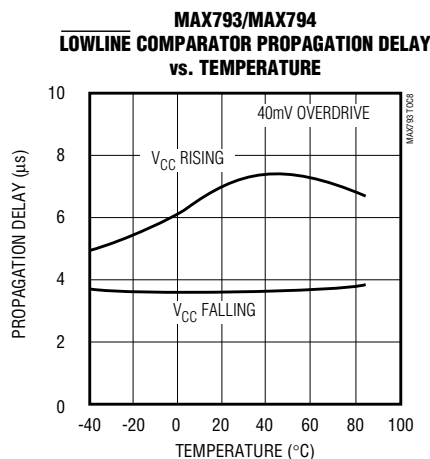
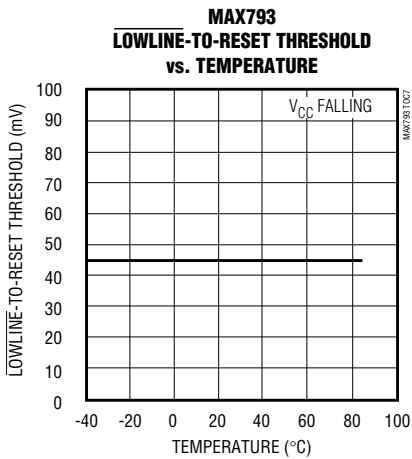
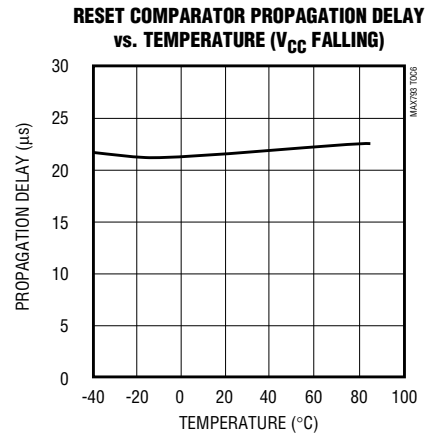
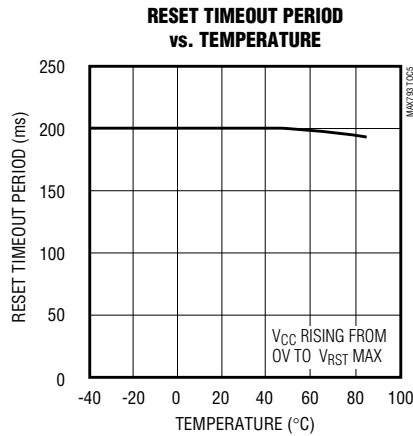
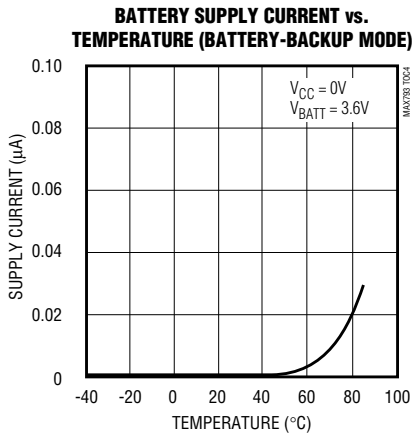
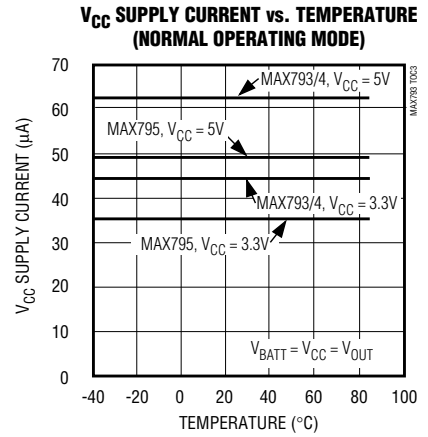
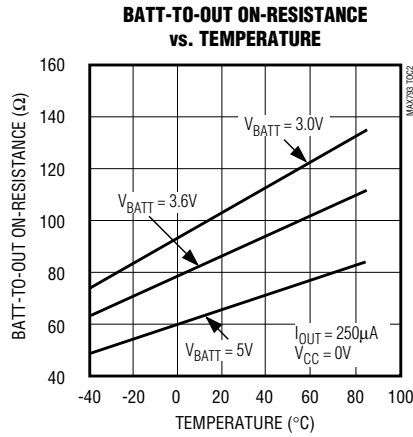
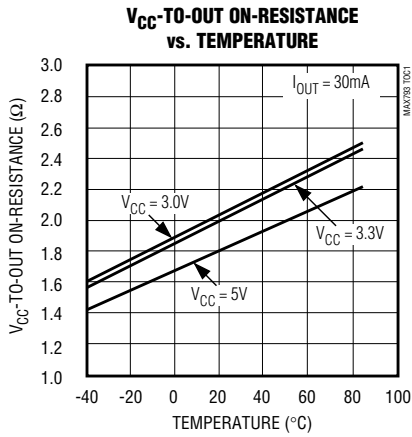

# 3.0V/3.3V Adjustable Microprocessor Supervisory Circuits

## Typical Operating Characteristics (continued)

( $T_A = +25^\circ\text{C}$ , unless otherwise noted.)

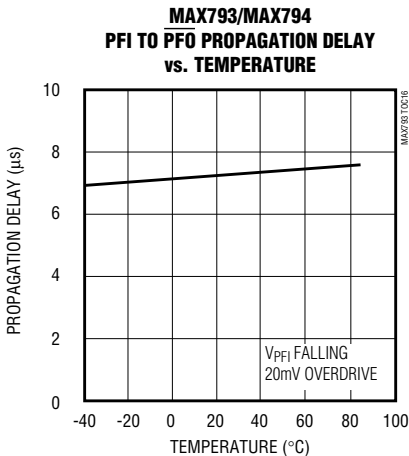
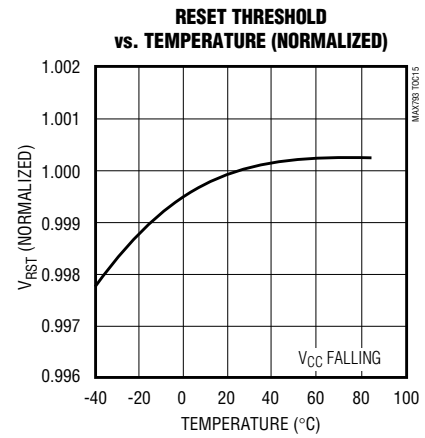
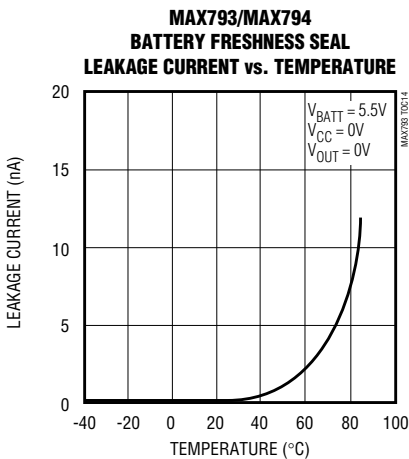
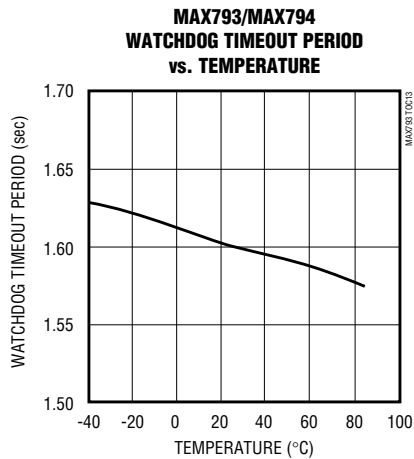
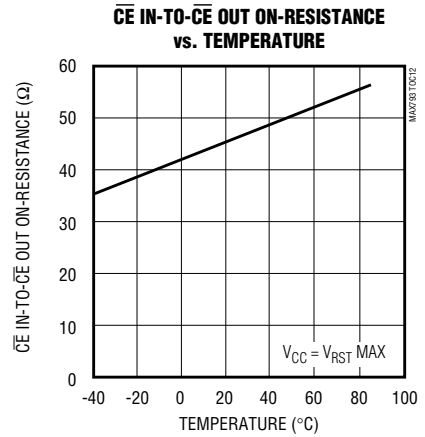
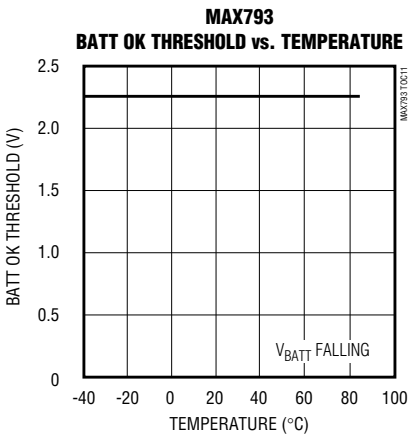
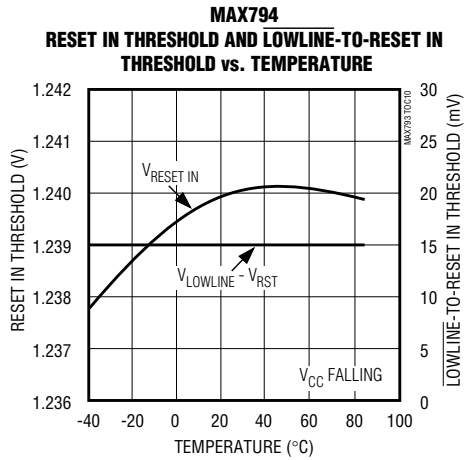

# 3.0V/3.3V Adjustable Microprocessor Supervisory Circuits

## Pin Description

MAX793/MAX794/MAX795

PIN		NAME	FUNCTION
MAX793/ MAX794	MAX795		
1	1	OUT	Supply Output for CMOS RAM. When $V_{CC}$ rises above the reset threshold or above $V_{BATT}$ , OUT is connected to $V_{CC}$ through an internal P-channel MOSFET switch. When $V_{CC}$ falls below $V_{SW}$ and $V_{BATT}$ , BATT connects to OUT.
2	2	$V_{CC}$	Main Supply Input
3	—	BATT OK (MAX793)	Battery Status Output. High in normal operating mode when $V_{BATT}$ exceeds $V_{BOK}$ , otherwise low. $V_{BATT}$ is checked continuously. Disabled and logic low while $V_{CC}$ is below $V_{SW}$ .
		RESET IN (MAX794)	Reset Input. Connect to an external resistor divider to select the reset threshold. The reset threshold can be programmed anywhere in the $V_{SW}$ to 5.5V range.
4	—	PFI	Power-Fail Comparator Input. When PFI is less than $V_{PFT}$ or when $V_{CC}$ falls below $V_{SW}$ , $\overline{PFO}$ goes low; otherwise, $\overline{PFO}$ remains high (see <i>Power-Fail Comparator</i> section). Connect to $V_{CC}$ if unused.
5	3	BATT ON	Logic Output/External Bypass Switch-Driver Output. High when OUT switches to BATT. Low when OUT switches to $V_{CC}$ . Connect the base/gate of PNP/PMOS transistor to BATT ON for $I_{OUT}$ requirements exceeding 75mA.
6	4	GND	Ground
7	—	$\overline{PFO}$	Power-Fail Comparator Output. When PFI is less than $V_{PFT}$ or when $V_{CC}$ falls below $V_{SW}$ , $\overline{PFO}$ goes low; otherwise, $\overline{PFO}$ remains high. $\overline{PFO}$ is also used to enable the battery freshness seal (see <i>Battery Freshness Seal</i> , and <i>Power-Fail Comparator</i> sections).
8	—	$\overline{MR}$	Manual Reset Input. A logic low on $\overline{MR}$ asserts reset. Reset remains asserted as long as $\overline{MR}$ is low and for 200ms after $\overline{MR}$ returns high. The active-low input has an internal 70 $\mu$ A pullup current. It can be driven from a TTL- or CMOS-logic line or shorted to ground with a switch. Leave open if unused.
9	—	$\overline{WDO}$	Watchdog Output. $\overline{WDO}$ goes low if WDI remains either high or low for longer than the watchdog timeout period. $\overline{WDO}$ returns high on the next transition of WDI. $\overline{WDO}$ is a logic high for $V_{SW} < V_{CC} < V_{RST}$ , and low when $V_{CC}$ is below $V_{SW}$ .
10	—	WDI	Watchdog Input. If WDI remains either high or low for longer than the watchdog timeout period, the internal watchdog timer runs out and $\overline{WDO}$ goes low. $\overline{WDO}$ returns high on the next transition of WDI. Connect $\overline{WDO}$ to $\overline{MR}$ to generate a reset due to a watchdog fault.
11	5	$\overline{CE}$ IN	Chip-Enable Input. The input to the chip-enable gating circuit. Connect to GND if unused.
12	6	$\overline{CE}$ OUT	Chip-Enable Output. $\overline{CE}$ OUT goes low only when $\overline{CE}$ IN is low and reset is not asserted. If $\overline{CE}$ IN is low when reset is asserted, $\overline{CE}$ OUT remains low for 10 $\mu$ s or until $\overline{CE}$ IN goes high, whichever occurs first. $\overline{CE}$ OUT is pulled up to OUT.
13	—	RESET	Active-High Reset Output. Sources and sinks current. RESET is the inverse of $\overline{RESET}$ .
14	—	$\overline{LOWLINE}$	Early Power-Fail Warning Output. Low when $V_{CC}$ falls to $V_{LR}$ . This output can be used to generate an NMI to provide early warning of imminent power failure.
15	7	$\overline{RESET}$	Open-Drain, Active-Low Reset Output. Pulses low for 200ms when triggered, and stays low whenever $V_{CC}$ is below the reset threshold or when $\overline{MR}$ is a logic low. It remains low for 200ms after either $V_{CC}$ rises above the reset threshold, the watchdog triggers a reset ( $\overline{WDO}$ connected to $\overline{MR}$ ), or $\overline{MR}$ goes low to high.
16	8	BATT	Backup-Battery Input. When $V_{CC}$ falls below $V_{SW}$ and $V_{BATT}$ , OUT switches from $V_{CC}$ to BATT. When $V_{CC}$ rises above the reset threshold or above $V_{BATT}$ , OUT reconnects to $V_{CC}$ . $V_{BATT}$ can exceed $V_{CC}$ . Connect $V_{CC}$ , OUT, and BATT together if no battery is used.

# 3.0V/3.3V Adjustable Microprocessor Supervisory Circuits

## Detailed Description

### General Timing Characteristics

The MAX793/MAX794/MAX795 are designed for 3.3V and 3V systems, and provide a number of supervisory functions (see the *Selector Guide* on the front page). Figures 1 and 2 show the typical timing relationships of the various outputs during power-up and power-down with typical  $V_{CC}$  rise and fall times.

### Manual Reset Input (MAX793/MAX794)

Many microprocessor-based products require manual-reset capability, allowing the operator, a test technician, or external logic circuitry to initiate a reset. On the MAX793/MAX794, a logic low on  $\overline{MR}$  asserts reset. Reset remains asserted while  $\overline{MR}$  is low, and for  $t_{RP}$  (200ms) after it returns high. During the first half of the reset time-

out period ( $t_{RP}$ ), the state of  $\overline{MR}$  is ignored if  $\overline{PFO}$  is externally forced low to facilitate enabling the battery freshness seal.  $\overline{MR}$  has an internal 70 $\mu$ A pullup current, so it can be left open if it is not used. This input can be driven with TTL- or CMOS-logic levels, or with open-drain/collector outputs. Connect a normally open momentary switch from  $\overline{MR}$  to GND to create a manual-reset function; external debounce circuitry is not required. If  $\overline{MR}$  is driven from long cables or the device is used in a noisy environment, connect a 0.1 $\mu$ F capacitor from  $\overline{MR}$  to ground to provide additional noise immunity.

### Reset Outputs

A microprocessor's ( $\mu$ P's) reset input starts the  $\mu$ P in a known state. These MAX793/MAX794/MAX795  $\mu$ P supervisory circuits assert a reset to prevent code execution errors during power-up, power-down, and

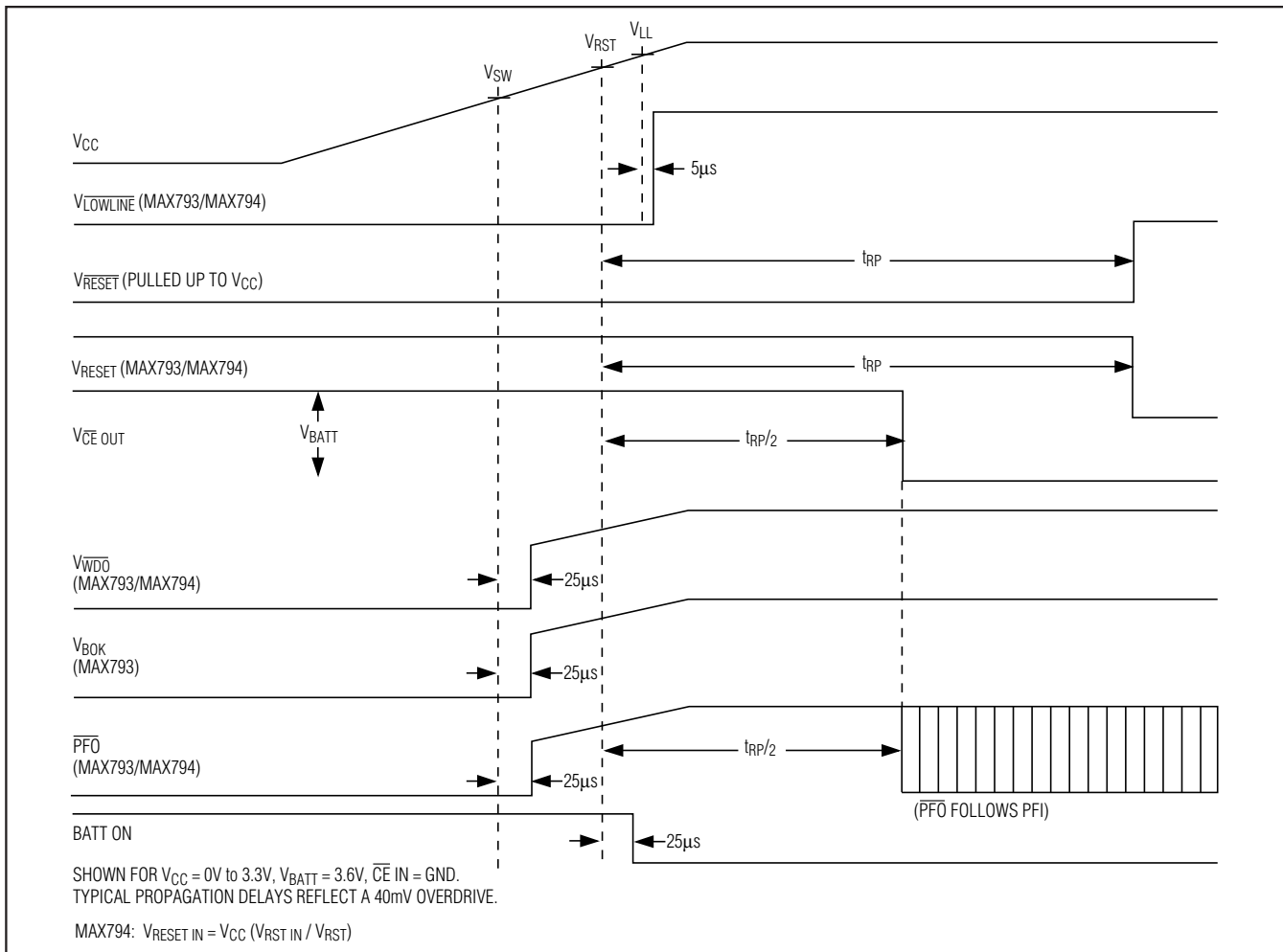

Figure 1. Timing Diagram,  $V_{CC}$  Rising



# 3.0V/3.3V Adjustable Microprocessor Supervisory Circuits

brownout conditions.  $\overline{\text{RESET}}$  is guaranteed to be a logic low for  $0V < V_{CC} < V_{RST}$ , provided  $V_{BATT}$  is greater than 1V. Without a backup battery ( $V_{BATT} = V_{CC} = V_{OUT}$ ),  $\overline{\text{RESET}}$  is guaranteed valid for  $V_{CC} \geq 1V$ . Once  $V_{CC}$  exceeds the reset threshold, an internal timer keeps  $\overline{\text{RESET}}$  low for the reset timeout period ( $t_{RP}$ ); after this interval,  $\overline{\text{RESET}}$  becomes high impedance (Figure 2).  $\overline{\text{RESET}}$  is an open-drain output, and requires a pullup resistor to  $V_{CC}$  (Figure 3). Use a  $4.7k\Omega$  to  $1M\Omega$  pullup resistor that provides sufficient current to assure the proper logic levels to the  $\mu P$ .

If a brownout condition occurs ( $V_{CC}$  dips below the reset threshold),  $\overline{\text{RESET}}$  goes low. Each time  $\overline{\text{RESET}}$  is asserted, it stays low for the reset timeout period. Any time  $V_{CC}$  goes below the reset threshold, the internal timer restarts.

The watchdog output ( $\overline{\text{WDO}}$ ) can also be used to initiate a reset. See the *Watchdog Output* section.

The  $\overline{\text{RESET}}$  output is the inverse of the  $\overline{\text{RESET}}$  output, and it can both source and sink current.

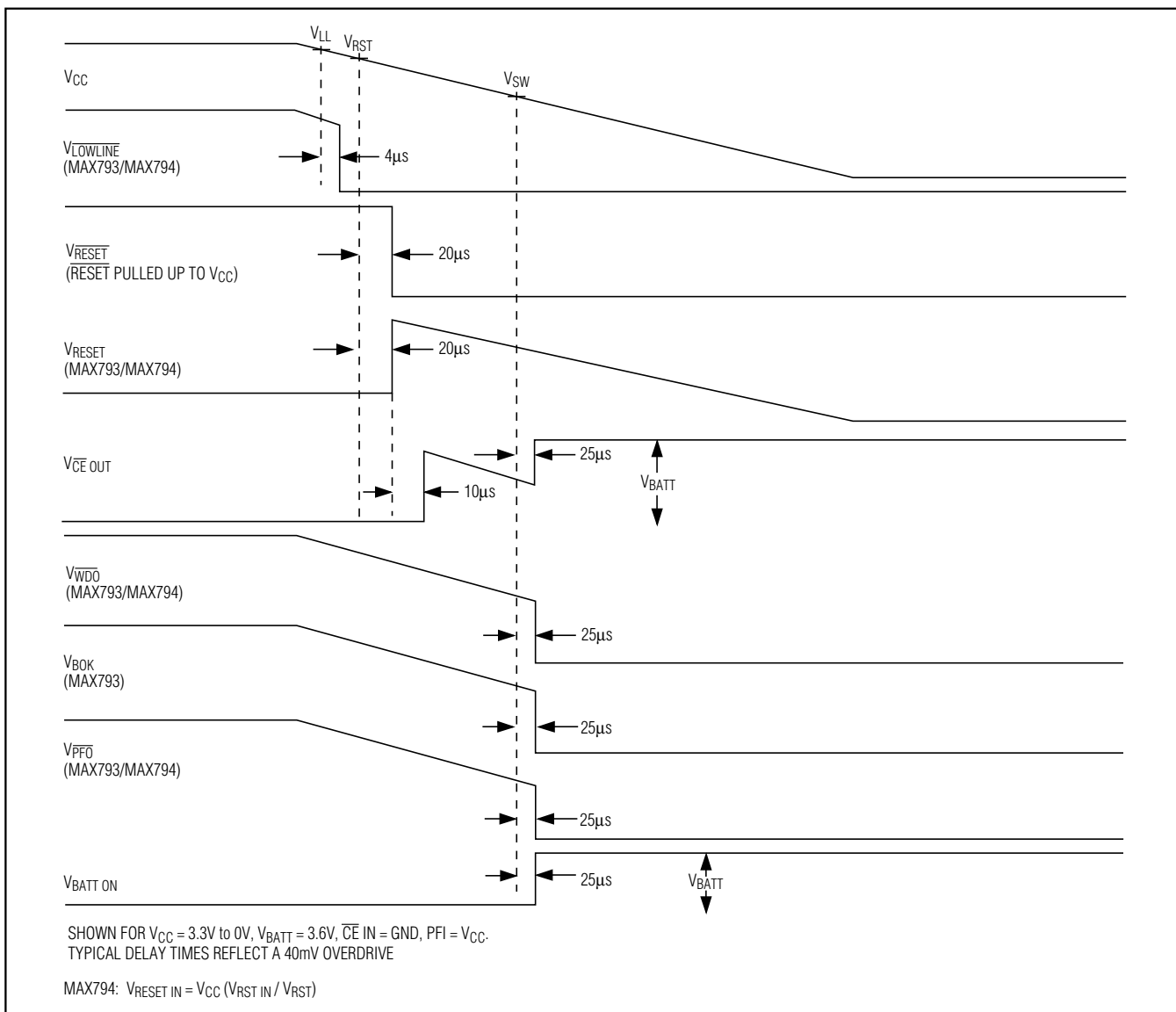

Figure 2. Timing Diagram,  $V_{CC}$  Falling

# 3.0V/3.3V Adjustable Microprocessor Supervisory Circuits

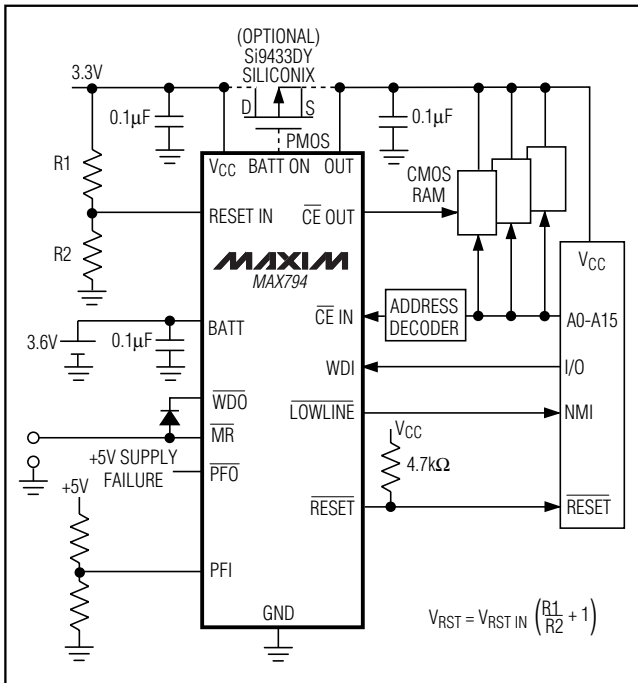

Figure 3. MAX794 Standard Application Circuit

### Reset Threshold

The MAX793T/MAX795T are intended for 3.3V systems with a  $\pm 5\%$  power-supply tolerance and a 10% systems tolerance. Except when MR is asserted, reset does not assert as long as the power supply remains above 3.15V (3.3V - 5%). Reset is guaranteed to assert before the power supply falls below 3.0V (3.3V - 10%).

The MAX793S/MAX795S are designed for 3.3V  $\pm 10\%$  power supplies. Except when MR is asserted, they are guaranteed not to assert reset as long as the supply remains above 3.0V (3.0V is just above 3.3V - 10%). Reset is guaranteed to assert before the power supply falls below 2.85V (3.3V - 14%).

The MAX793R/MAX795R are optimized to monitor 3.0V  $\pm 10\%$  power supplies. Reset does not occur until VCC falls below 2.7V (3.0V - 10%), but is guaranteed to occur before the supply falls below 2.55V (3.0V - 15%).

Program the MAX794's reset threshold with an external voltage divider to RESET IN. The reset-threshold tolerance is a combination of the RESET IN tolerance and the tolerance of the resistors used to make the external voltage divider. Calculate the reset threshold as follows:

$$V_{RST} = V_{RST\ IN} \left( \frac{R1}{R2} + 1 \right)$$

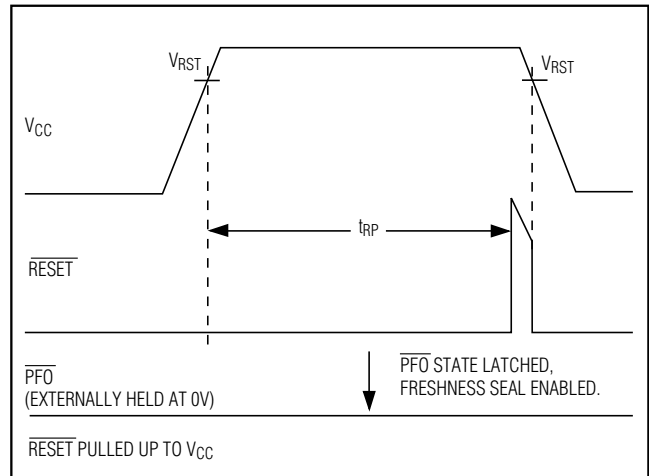

Figure 4. Battery Freshness Seal Enable Timing

Using the standard application circuit (Figure 3), the reset threshold can be programmed anywhere in the range of V<sub>SW</sub> (the battery switch threshold) to 5.5V. Reset is asserted when VCC falls below V<sub>SW</sub>.

### Battery Freshness Seal

The MAX793/MAX794's battery freshness seal disconnects the backup battery from internal circuitry until it is needed. This allows an OEM to ensure that the backup battery connected to BATT is fresh when the final product is put to use. To enable the freshness seal, connect a battery to BATT, ground PFO, bring VCC above the reset threshold, and hold it there until reset is deasserted following the reset timeout period, then bring VCC back down again (Figure 4). Once the battery freshness seal is enabled (disconnecting the backup battery from the internal circuitry and anything connected to OUT), it remains enabled until VCC is brought above V<sub>RST</sub>. Note that connecting PFO to MR does not interfere with battery freshness seal operation.

### BATT OK Output (MAX793)

BATT OK indicates the status of the backup battery. When reset is not asserted, the MAX793 checks the battery voltage continuously. If V<sub>BATT</sub> is below V<sub>BOK</sub> (2.0V min), BATT OK goes low; otherwise, it remains pulled up to VCC. BATT OK also goes low when VCC goes below V<sub>SW</sub>.

### Watchdog Input (MAX793/MAX794)

In the MAX793/MAX794, the watchdog circuit monitors the  $\mu P$ 's activity. If the  $\mu P$  does not toggle the watchdog input (WDI) within 1.6s, WDO goes low. The internal 1.6s timer is cleared and WDO returns high either when

# 3.0V/3.3V Adjustable Microprocessor Supervisory Circuits

MAX793/MAX794/MAX795

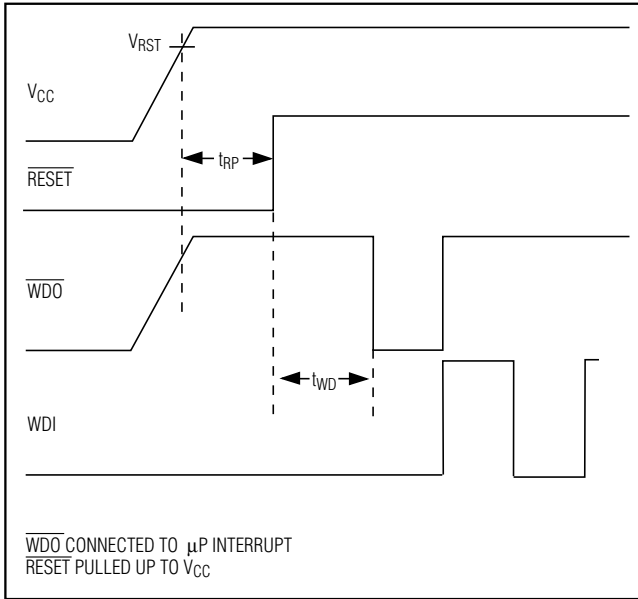

Figure 5. Watchdog Timing Relationship

a reset occurs or when a transition (low-to-high or high-to-low) takes place at WDI. As long as reset is asserted, the timer remains cleared and does not count. As soon as reset is released or WDI changes state, the timer starts counting (Figure 5). WDI can detect pulses as short as 100ns. Unlike the 5V MAX690 family, the watchdog function **cannot** be disabled.

### Watchdog Output (MAX793/MAX794)

In the MAX793/MAX794,  $\overline{WDO}$  remains high ( $\overline{WDO}$  is pulled up to  $V_{CC}$ ) if there is a transition or pulse at WDI during the watchdog timeout period.  $\overline{WDO}$  goes low if no transition occurs at WDI during the watchdog timeout period. The watchdog function is disabled and  $\overline{WDO}$  is a logic high when reset is asserted if  $V_{CC}$  is above  $V_{sw}$ .  $\overline{WDO}$  is a logic low when  $V_{CC}$  is below  $V_{sw}$ .

If a system reset is desired on every watchdog fault, simply diode-OR connect  $\overline{WDO}$  to  $\overline{MR}$  (Figure 6). When a watchdog fault occurs in this mode,  $\overline{WDO}$  goes low, pulling  $\overline{MR}$  low, which causes a reset pulse to be issued. Ten microseconds after reset is asserted, the watchdog timer clears and  $\overline{WDO}$  returns high. This delay results in a 10 $\mu$ s pulse at  $\overline{WDO}$ , allowing external circuitry to capture a watchdog fault indication. A continuous high or low on WDI causes 200ms reset pulses to be issued every 1.6s.

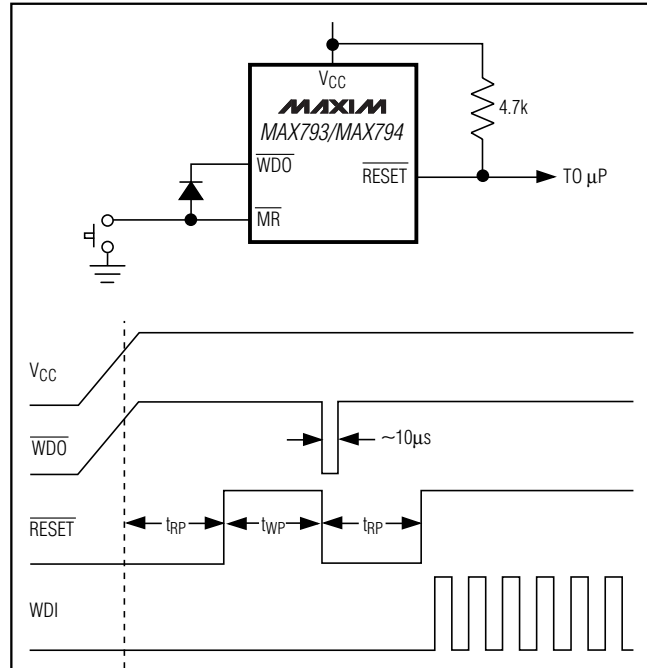

Figure 6. Generating a Reset on Each Watchdog Fault

### Chip-Enable Signal Gating

Internal gating of chip-enable (CE) signals prevents erroneous data from corrupting CMOS RAM in the event of an undervoltage condition. The MAX793/MAX794/MAX795 use a series transmission gate from  $\overline{CE}$  IN to  $\overline{CE}$  OUT. During normal operation (reset not asserted), the CE transmission gate is enabled and passes all CE transitions. When reset is asserted, this path becomes disabled, preventing erroneous data from corrupting the CMOS RAM. The short CE propagation delay from  $\overline{CE}$  IN to  $\overline{CE}$  OUT enables these  $\mu$ P supervisors to be used with most  $\mu$ Ps. If  $\overline{CE}$  IN is low when reset asserts,  $\overline{CE}$  OUT remains low for typically 10 $\mu$ s to permit completion of the current write cycle.

### Chip-Enable Input

The CE transmission gate is disabled and  $\overline{CE}$  IN is high impedance (disabled mode) while reset is asserted. During a power-down sequence when  $V_{CC}$  passes the reset threshold, the CE transmission gate disables and  $\overline{CE}$  IN immediately becomes high impedance if the voltage at  $\overline{CE}$  IN is high. If  $\overline{CE}$  IN is low when reset asserts, the CE transmission gate disables at the moment  $\overline{CE}$  IN goes high, or 10 $\mu$ s after reset asserts, whichever occurs first (Figure 8). This permits the current write cycle to complete during power-down.

# 3.0V/3.3V Adjustable Microprocessor Supervisory Circuits

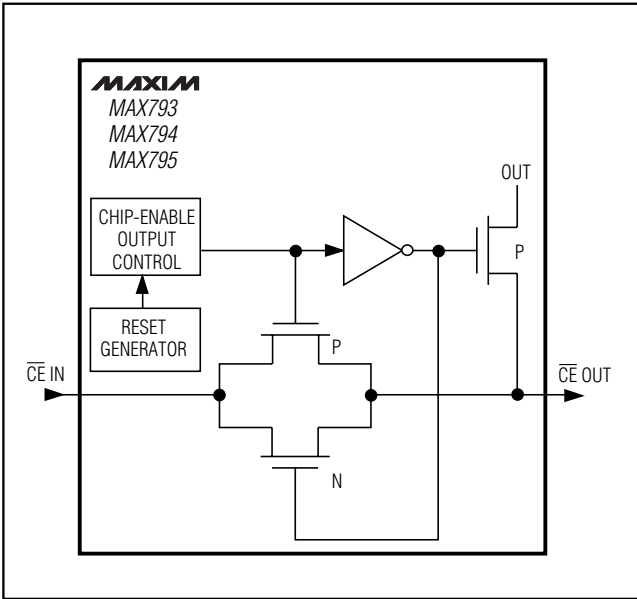

Figure 7. Chip-Enable Transmission Gate

The CE transmission gate remains disabled and  $\overline{CE}$  IN remains high impedance (regardless of  $\overline{CE}$  IN activity) for the first half of the reset timeout period ( $t_{RP} / 2$ ), any time a reset is generated. While disabled,  $\overline{CE}$  IN is high impedance. When the CE transmission gate is enabled, the impedance of  $\overline{CE}$  IN appears as a  $46\Omega$  resistor in series with the load at  $\overline{CE}$  OUT.

The propagation delay through the CE transmission gate depends on  $V_{CC}$ , the source impedance of the drive connected to  $\overline{CE}$  IN, and the loading on  $\overline{CE}$  OUT (see the Chip-Enable Propagation Delay vs.  $\overline{CE}$  OUT Load Capacitance graph in the *Typical Operating Characteristics*). The CE propagation delay is production tested from the 50% point on  $\overline{CE}$  IN to the 50% point on  $\overline{CE}$  OUT using a  $50\Omega$  driver and  $50pF$  of load capacitance (Figure 9). For minimum propagation delay, minimize the capacitive load at  $\overline{CE}$  OUT and use a low-output-impedance driver.

### Chip-Enable Output

When the CE transmission gate is enabled, the impedance of  $\overline{CE}$  OUT is equivalent to a  $46\Omega$  resistor in series with the source driving  $\overline{CE}$  IN. In the disabled mode, the transmission gate is off and an active pullup connects  $\overline{CE}$  OUT to OUT (Figure 8). This pullup turns off when the transmission gate is enabled.

### Early Power-Fail Warning (MAX793/MAX794)

Critical systems often require an early warning indicating that power is failing. This warning provides time for the  $\mu P$  to store vital data and take care of any additional "housekeeping" functions, before the power supply gets too far out of tolerance for the  $\mu P$  to operate reliably. The MAX793/MAX794 offer two methods of achieving this early warning. If access to the unregulated supply is feasible, the power-fail comparator input (PFI) can be connected to the unregulated supply

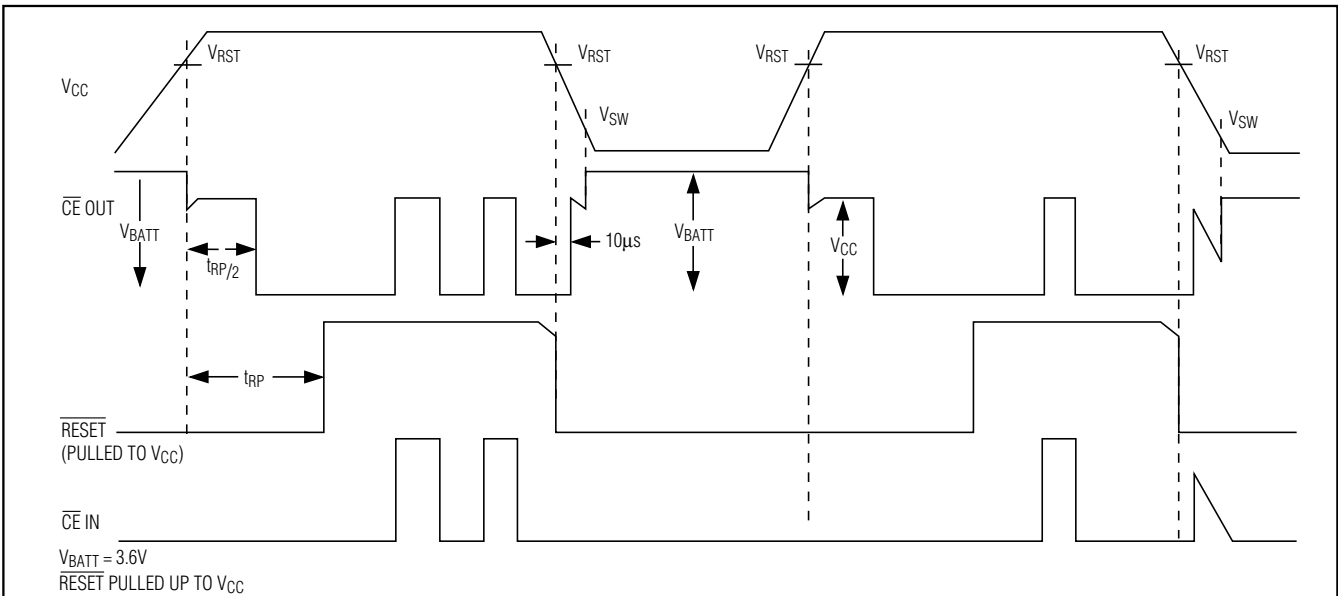

Figure 8. Chip-Enable Timing

# 3.0V/3.3V Adjustable Microprocessor Supervisory Circuits

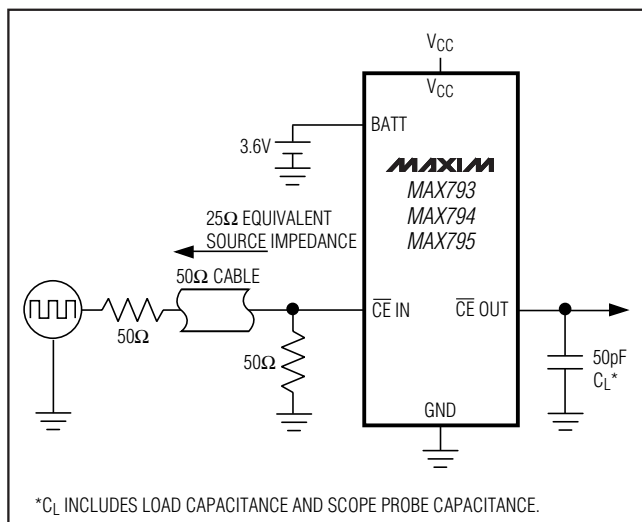

Figure 9. CE Propagation Delay Test Circuit

through a voltage divider, with the power-fail comparator output ( $\overline{\text{PFO}}$ ) providing the NMI to the  $\mu\text{P}$  (Figure 10). If there is no easy access to the unregulated supply, the  $\overline{\text{LOWLINE}}$  output can be used to generate an NMI to the  $\mu\text{P}$  (see  $\overline{\text{LOWLINE}}$  Output section).

### $\overline{\text{LOWLINE}}$ Output (MAX793/MAX794)

The low-line comparator monitors  $V_{\text{CC}}$  with a threshold voltage typically 45mV above the reset threshold (10mV of hysteresis) for the MAX793, and 15mV above RESET IN (4mV of hysteresis) for the MAX794. For normal operation ( $V_{\text{CC}}$  above the reset threshold),  $\overline{\text{LOWLINE}}$  is

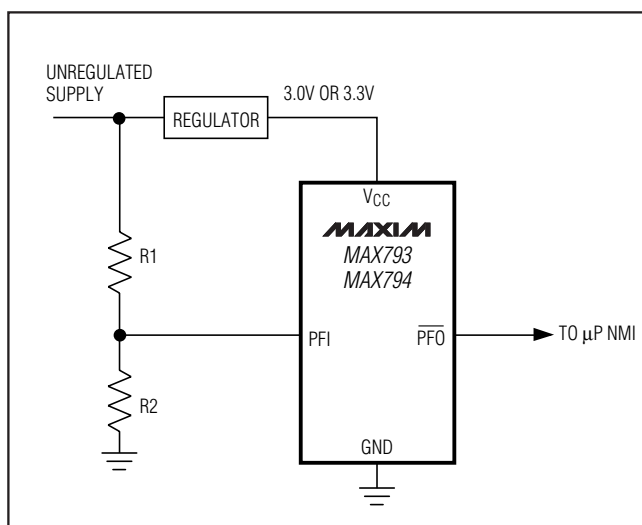

Figure 10. Using the Power-Fail Comparator to Generate Power-Fail Warning

pulled to  $V_{\text{CC}}$ . Use  $\overline{\text{LOWLINE}}$  to provide an NMI to the  $\mu\text{P}$  when power begins to fall.

In most battery-operated portable systems, reserve energy in the battery provides ample time to complete the shutdown routine once the low-line warning is encountered and before reset asserts. If the system must also contend with a more rapid  $V_{\text{CC}}$  fall time, such as when the main battery is disconnected or a high-side switch is opened during normal operation, use capacitance on the  $V_{\text{CC}}$  line to provide time to execute the shutdown routine (Figure 11).

First, calculate the worst-case time required for the system to perform its shutdown routine. Then, with the worst-case shutdown time, the worst-case load current, and the minimum low-line to reset threshold ( $V_{\text{LR min}}$ ), calculate the amount of capacitance required to allow the shutdown routine to complete before reset is asserted:

$$C_{\text{HOLD}} > I_{\text{LOAD}} \times t_{\text{SHDN}} / V_{\text{LR}}$$

where  $I_{\text{LOAD}}$  is the current being drained from the capacitor,  $V_{\text{LR}}$  is the low-line to reset threshold difference ( $V_{\text{LL}} - V_{\text{RST}}$ ), and  $t_{\text{SHDN}}$  is the time required for the system to complete an orderly shutdown routine.

### Power-Fail Comparator (MAX793/MAX794)

The MAX793/MAX794's PFI input is compared to an internal reference. If PFI is less than the power-fail threshold ( $V_{\text{PFT}}$ ),  $\overline{\text{PFO}}$  goes low. The power-fail comparator is intended for use as an undervoltage detector to signal a failing power supply (Figure 12). However, the comparator does not need to be dedicated to this function because it is completely separate from the rest of the circuitry.

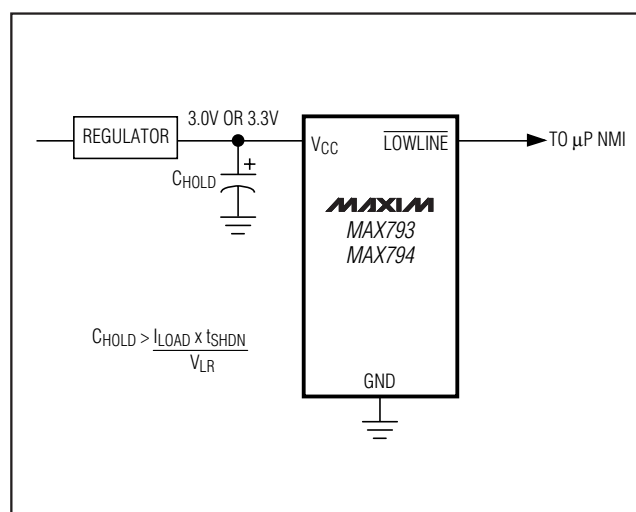

Figure 11. Using  $\overline{\text{LOWLINE}}$  to Provide Power-Fail Warning to the  $\mu\text{P}$

## 3.0V/3.3V Adjustable Microprocessor Supervisory Circuits

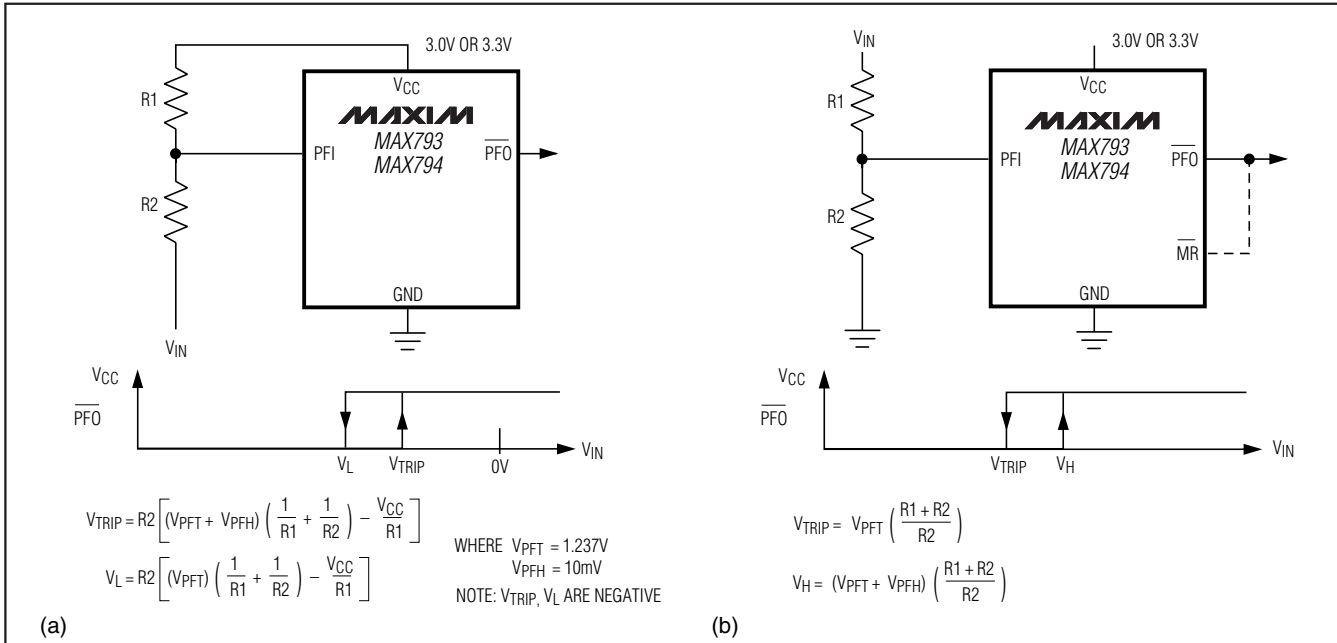

Figure 12. Using the Power-Fail Comparator to Monitor an Additional Power Supply: (a)  $V_{IN}$  Is Negative, (b)  $V_{IN}$  Is Positive

The power-fail comparator turns off and  $\overline{PFO}$  goes low when  $V_{CC}$  falls below  $V_{SW}$  on power-down. During the first half of the reset timeout period ( $t_{RP}$ ),  $\overline{PFO}$  is forced high, irrespective of  $V_{PFI}$ . At the beginning of the second half of  $t_{RP}$ , the power-fail comparator is enabled and  $\overline{PFO}$  follows  $PFI$ . If the comparator is unused, connect  $PFI$  to  $V_{CC}$  and leave  $\overline{PFO}$  unconnected.  $\overline{PFO}$  can be connected to  $\overline{MR}$  so that a low voltage on  $PFI$  generates a reset (Figure 12b). In this configuration, when the monitored voltage causes  $PFI$  to fall below  $V_{PFT}$ ,  $\overline{PFO}$  pulls  $\overline{MR}$  low, causing a reset to be asserted. Reset remains asserted as long as  $\overline{PFO}$  holds  $\overline{MR}$  low, and for 200ms after  $\overline{PFO}$  pulls  $\overline{MR}$  high when the monitored supply is above the programmed threshold.

### Backup-Battery Switchover

In the event of a brownout or power failure, it may be necessary to preserve the contents of RAM. With a backup battery installed at  $BATT$ , the devices automatically switch RAM to backup power when  $V_{CC}$  falls. In order to allow the backup battery (e.g., a 3.6V lithium cell) to have a higher voltage than  $V_{CC}$ , this family of  $\mu P$  supervisors (designed for 3.3V and 3V systems) does not always connect  $BATT$  to  $OUT$  when  $V_{BATT}$  is greater than  $V_{CC}$ .  $BATT$  connects to  $OUT$  (through a  $140\Omega$  switch) either when  $V_{CC}$  falls below  $V_{SW}$  and

$V_{BATT}$  is greater than  $V_{CC}$ , or when  $V_{CC}$  falls below 1.75V (typ) regardless of the  $BATT$  voltage.

Switchover at  $V_{SW}$  ensures that battery-backup mode is entered before  $V_{OUT}$  gets too close to the 2.0V minimum required to reliably retain data in most CMOS RAM, (switchover at higher  $V_{CC}$  voltages would decrease backup-battery life). When  $V_{CC}$  recovers, switchover is deferred either until  $V_{CC}$  crosses  $V_{BATT}$  if  $V_{BATT}$  is below  $V_{RST}$ , or when  $V_{CC}$  rises above the reset threshold ( $V_{RST}$ ) if  $V_{BATT}$  is above  $V_{RST}$ . This power-up switchover technique prevents  $V_{CC}$  from charging the backup battery through  $OUT$  when using an external transistor driven by  $BATT$  ON.  $OUT$  connects to  $V_{CC}$  through a  $4\Omega$  (max) PMOS power switch when  $V_{CC}$  crosses the reset threshold (Figure 13).

### BATT ON (MAX793/MAX794)

$BATT$  ON is high when  $OUT$  is connected to  $BATT$ . Although  $BATT$  ON can be used as a logic output to indicate the battery switchover status, it is most often used as a gate or base drive for an external pass transistor for high-current applications (see *Driving an External Switch with BATT ON* in the *Applications Information* section). When  $V_{CC}$  exceeds  $V_{RST}$  on power-up,  $BATT$  ON sinks 3.2mA at 0.4V. In battery-backup mode, this terminal sources 100 $\mu A$  from  $BATT$ .

# 3.0V/3.3V Adjustable Microprocessor Supervisory Circuits

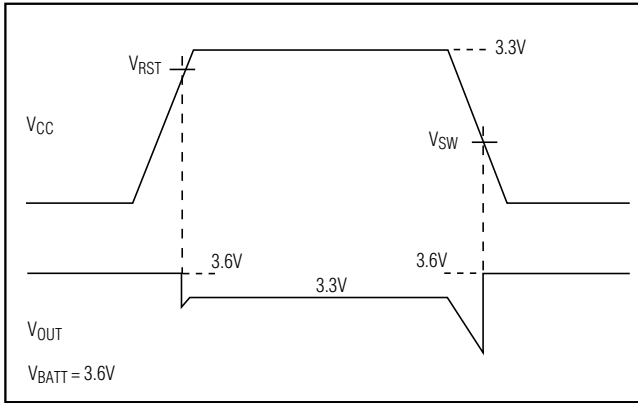

Figure 13. Battery Switchover Timing

**Table 1. Input and Output Status in Battery-Backup Mode**

PIN NAME	STATUS
OUT	Connected to BATT through an internal 140Ω switch
VCC	Disconnected from OUT
BATT ON	Pulled up to BATT
BATT OK	Logic low
PFI	Disabled
PFO	Logic low
MR	Disabled, but still pulled up to VCC
WDO	Logic low
WDI	Disabled
RESET	Logic low
RESET	Pulled up to VCC
BATT	Connected to OUT
LOWLINE	Logic low
CE IN	High impedance
CE OUT	Pulled to BATT

## Applications Information

These  $\mu\text{P}$  supervisory circuits are not short-circuit protected. Shorting  $V_{\text{OUT}}$  to ground, excluding power-up transients such as charging a decoupling capacitor, destroys the device. Decouple both  $V_{\text{CC}}$  and BATT pins to ground by placing 0.1 $\mu\text{F}$  ceramic capacitors as close to the device as possible.

### Driving an External Switch with BATT ON

BATT ON can be directly connected to the base of a PNP transistor or the gate of a PMOS transistor. The PNP connection is straightforward: connect the emitter

to  $V_{\text{CC}}$ , the collector to OUT, and the base to BATT ON (Figure 14a). No current-limiting resistor is required, but a resistor connecting the base of the PNP to BATT ON can be used to limit the current drawn from  $V_{\text{CC}}$ , prolonging battery life in portable equipment.

If you are using a PMOS transistor, however, it must be connected backwards from the traditional method. Connect the gate to BATT ON, the drain to  $V_{\text{CC}}$ , and the source to OUT (Figure 14b). This method orients the body diode from  $V_{\text{CC}}$  to OUT and prevents the backup battery from discharging through the FET when its gate is high. Two PMOS transistors in the Siliconix LITTLE FOOT™ series are specified with  $V_{\text{GS}}$  down to -2.7V. The Si9433DY has a maximum 100mΩ drain-source on-resistance with 2.7V of gate drive and a 2A drain-source current. The Si9434DY specifies a 60mΩ drain-source on-resistance with 2.7V of gate drive and a 5.1A drain-source current.

### Using a SuperCap™ as a Backup Power Source

SuperCaps™ are capacitors with extremely high capacitance values (e.g., order of 0.47F) for their size. Figure 15 shows two ways to use a SuperCap as a backup power source. The SuperCap can be connected through a diode to the 3V input (Figure 15a); or, if a 5V supply is also available, the SuperCap can be charged up to the 5V supply (Figure 15b), allowing a longer backup period. Since  $V_{\text{BATT}}$  can exceed  $V_{\text{CC}}$  while  $V_{\text{CC}}$  is above the reset threshold, there are no special precautions when using these  $\mu\text{P}$  supervisors with a SuperCap.

### Operation without a Backup Power Source

These  $\mu\text{P}$  supervisors were designed for battery-backed applications. If a backup battery is not used, connect BATT, OUT, and  $V_{\text{CC}}$  together, or use a different  $\mu\text{P}$  supervisor. See the  $\mu\text{P}$  Supervisory Circuits table at the end of this data sheet.

### Replacing the Backup Battery

The backup power source can be removed while  $V_{\text{CC}}$  remains valid, without danger of triggering a reset pulse, provided that BATT is decoupled with a 0.1 $\mu\text{F}$  capacitor to ground. As long as  $V_{\text{CC}}$  stays above the reset threshold, battery-backup mode cannot be entered.

™ LITTLE FOOT is a trademark of Siliconix Inc.  
SuperCap is a trademark of Baknor Industries.

# 3.0V/3.3V Adjustable Microprocessor Supervisory Circuits

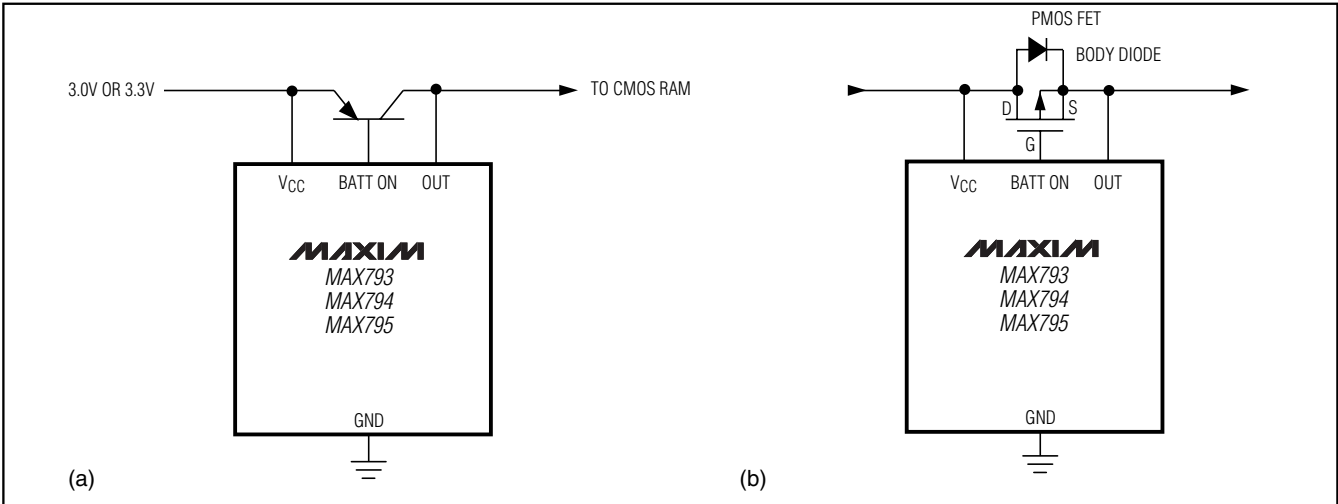

Figure 14. Driving an External Transistor with BATT ON

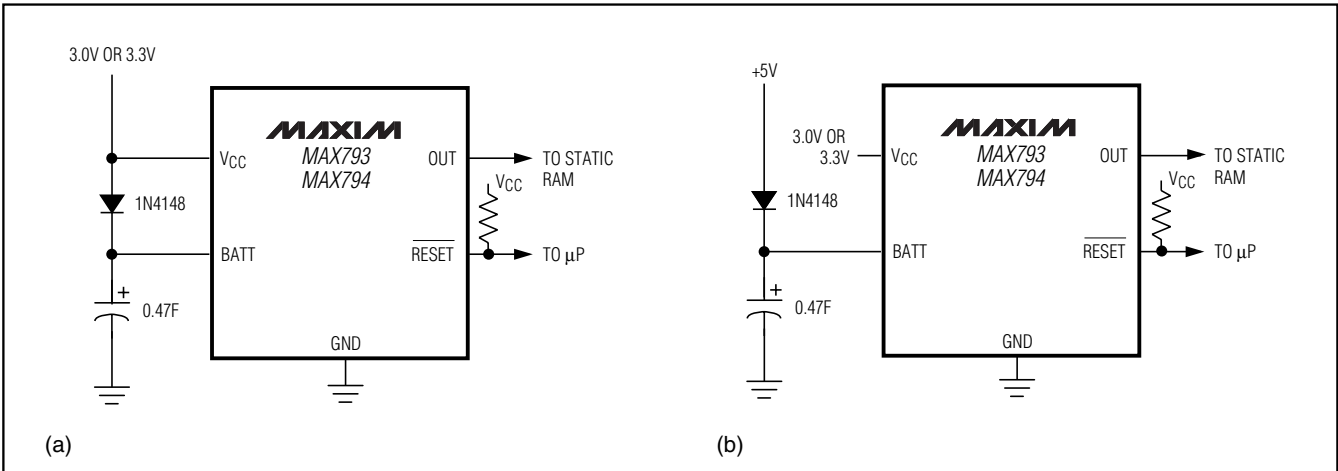

Figure 15. Using a SuperCap™ as a Backup Source

## Adding Hysteresis to the Power-Fail Comparator (MAX793/MAX794)

The power-fail comparator has a typical input hysteresis of 10mV. This is sufficient for most applications where a power-supply line is being monitored through an external voltage divider (see the section *Monitoring an Additional Power Supply*).

If additional noise margin is desired, connect a resistor between PFO and PFI as shown in Figure 16a. Select the ratio of R1 and R2 such that PFI sees  $V_{PFT}$  when  $V_{IN}$  falls to its trip point ( $V_{TRIP}$ ). R3 adds the additional hysteresis and should typically be more than 10 times the value of R1 or R2. The hysteresis window extends

both above ( $V_H$ ) and below ( $V_L$ ) the original trip point ( $V_{TRIP}$ ).

Connecting an ordinary signal diode in series with R3, as shown in Figure 16b, causes the lower trip point ( $V_L$ ) to coincide with the trip point without hysteresis ( $V_{TRIP}$ ), so the entire hysteresis window occurs above  $V_{TRIP}$ . This method provides additional noise margin without compromising the accuracy of the power-fail threshold when the monitored voltage is falling. It is useful for accurately detecting when a voltage falls past a threshold. The current through R1 and R2 should be at least 1 $\mu$ A to ensure that the 25nA (max over temperature) PFI input current does not shift the trip point. R3 should be larger than 82k $\Omega$  so it does not load down the PFO pin. Capacitor C1 is optional, and adds noise rejection.



# 3.0V/3.3V Adjustable Microprocessor Supervisory Circuits

MAX793/MAX794/MAX795

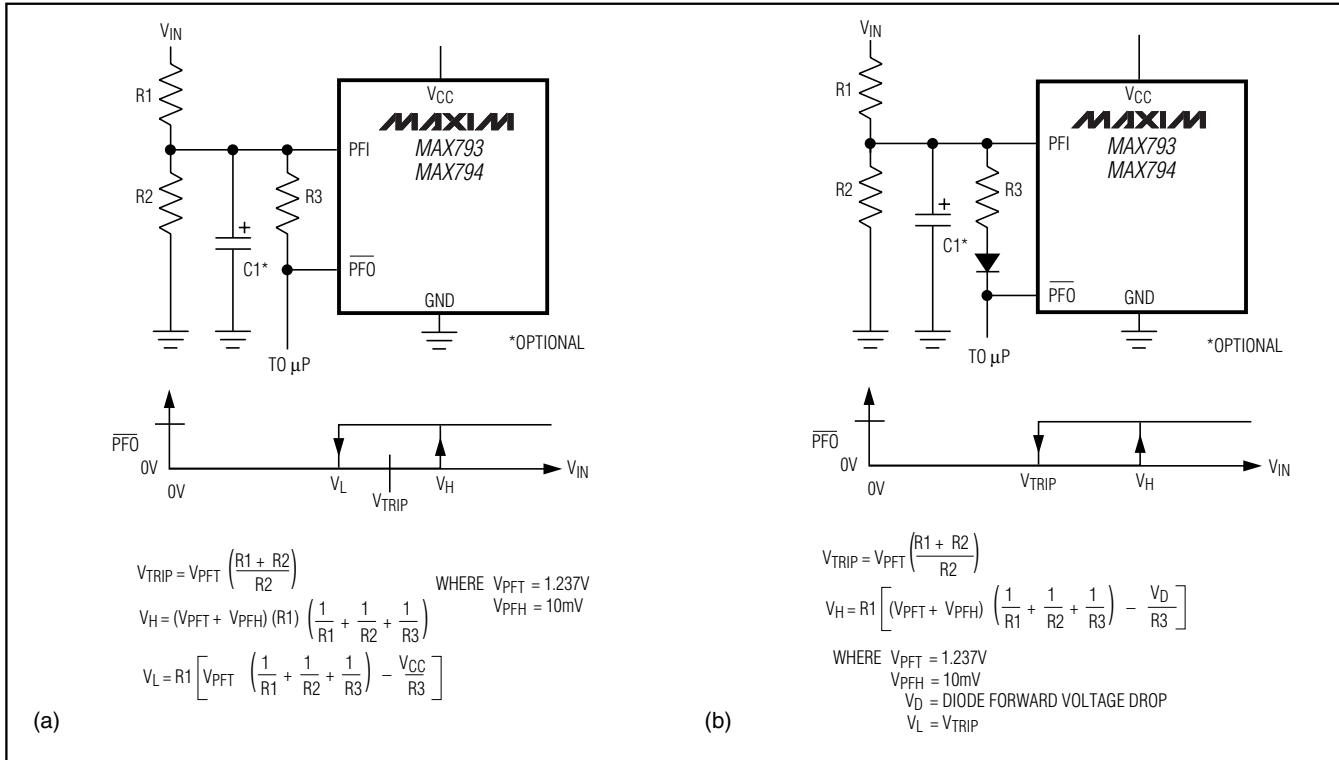

Figure 16. Adding Hysteresis to the Power-Fail Comparator: (a) Symmetrical Hysteresis, (b) Hysteresis Only on Rising  $V_{IN}$

## Monitoring an Additional Power Supply

These  $\mu P$  supervisors can monitor either positive or negative supplies using a resistor voltage divider to PFI.  $\overline{PFO}$  can be used to generate an interrupt to the  $\mu P$  or to cause reset to assert (Figure 12).

## Interfacing to $\mu P$ s with Bidirectional Reset Pins

Since the  $\overline{RESET}$  output is open drain, the MAX793/MAX794/MAX795 interface easily with  $\mu P$ s that have bidirectional reset pins, such as the Motorola 68HC11. Connecting the  $\overline{RESET}$  output of the  $\mu P$  supervisor directly to the  $\overline{RESET}$  input of the microcontroller with a single pullup resistor allows either device to assert reset (Figure 17).

## Negative-Going $V_{CC}$ Transients

These supervisors are relatively immune to short-duration negative-going  $V_{CC}$  transients (glitches) while issuing resets to the  $\mu P$  during power-up, power-down, and brownout conditions. Therefore, resetting the  $\mu P$  when  $V_{CC}$  experiences only small glitches is usually not recommended.

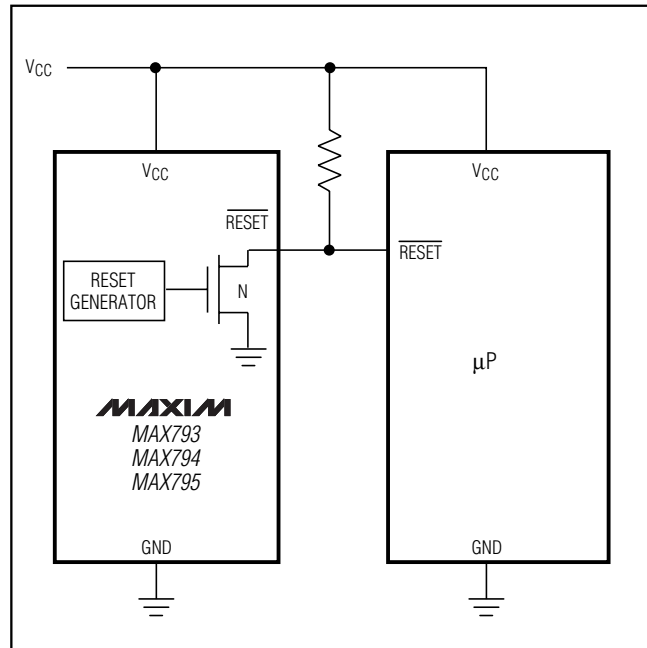

Figure 17. Interfacing to  $\mu P$ s with Bidirectional Reset I/O

## 3.0V/3.3V Adjustable Microprocessor Supervisory Circuits

Figure 18 shows maximum transient duration vs. reset-comparator overdrive, for which reset pulses are **not** generated. The graph was produced using negative-going VCC pulses, starting at 3.3V and ending below the reset threshold by the magnitude indicated (reset comparator overdrive). The graph shows the maximum pulse width a negative-going VCC transient can typically have without causing a reset pulse to be issued. As the amplitude of the transient increases (i.e., goes farther below the reset threshold), the maximum allowable pulse width decreases. Typically, a VCC transient that goes 40mV below the reset threshold and lasts for 10µs or less does not cause a reset pulse to be issued.

A 0.1µF bypass capacitor mounted close to the VCC pin provides additional transient immunity.

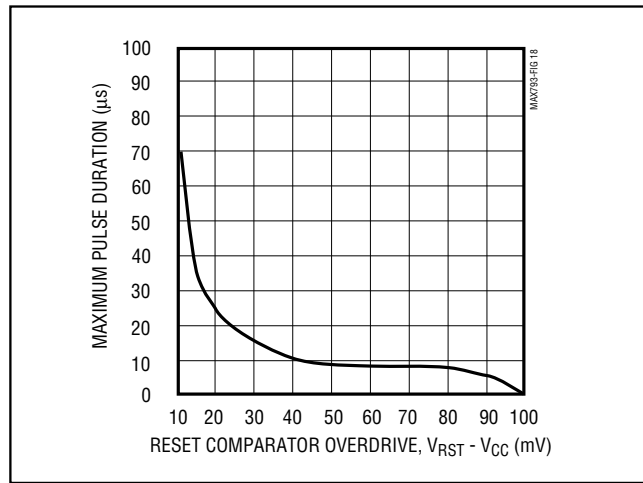

Figure 18. Maximum Transient Duration without Causing a Reset Pulse vs. Reset Comparator Overdrive

### Watchdog Software Considerations

There is a way to help the watchdog timer monitor software execution more closely, which involves setting and resetting the watchdog input at different points in the program rather than pulsing the watchdog input high-low-high or low-high-low. This technique avoids a stuck loop, in which the watchdog timer would continue to be reset within the loop, keeping the watchdog from timing out. Figure 19 shows an example of a flow diagram where the I/O driving the watchdog input is set high at the beginning of the program, set low at the beginning of every subroutine or loop, then set high again when the program returns to the beginning. If the program should hang in any subroutine, the problem would quickly be corrected, since the I/O is continually set low and the watchdog timer is allowed to time out, causing a reset or interrupt to be issued.

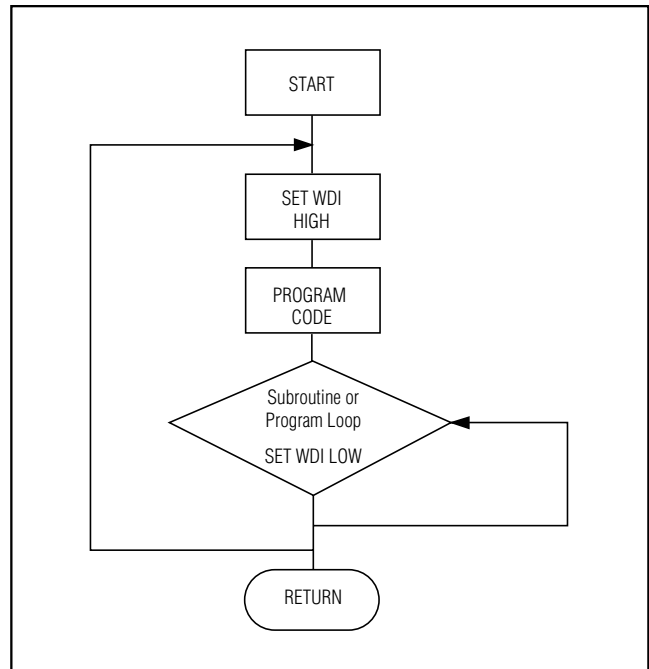

Figure 19. Watchdog Flow Diagram

# 3.0V/3.3V Adjustable Microprocessor Supervisory Circuits

MAX793/MAX794/MAX795

## Ordering Information (continued)

PART*	TEMP RANGE	PIN-PACKAGE
MAX794CPE	0°C to +70°C	16 Plastic DIP
MAX794CSE	0°C to +70°C	16 Narrow SO
MAX794EPE	-40°C to +85°C	16 Plastic DIP
MAX794ESE	-40°C to +85°C	16 Narrow SO
MAX795_CPA	0°C to +70°C	8 Plastic DIP
MAX795_CSA	0°C to +70°C	8 SO
MAX795_EPA	-40°C to +85°C	8 Plastic DIP
MAX795_ESA	-40°C to +85°C	8 SO

\*The MAX793/MAX795 offer a choice of reset threshold voltage. Select the letter corresponding to the desired reset threshold voltage range (T = 3.00V to 3.15V, S = 2.85V to 3.00V, R = 2.55V to 2.70V) and insert it into the blank to complete the part number. The MAX794's reset threshold is adjustable.

Devices are available in both leaded and lead-free packaging. Specify lead free by adding the + symbol at the end of the part number when ordering.

## Pin Configurations

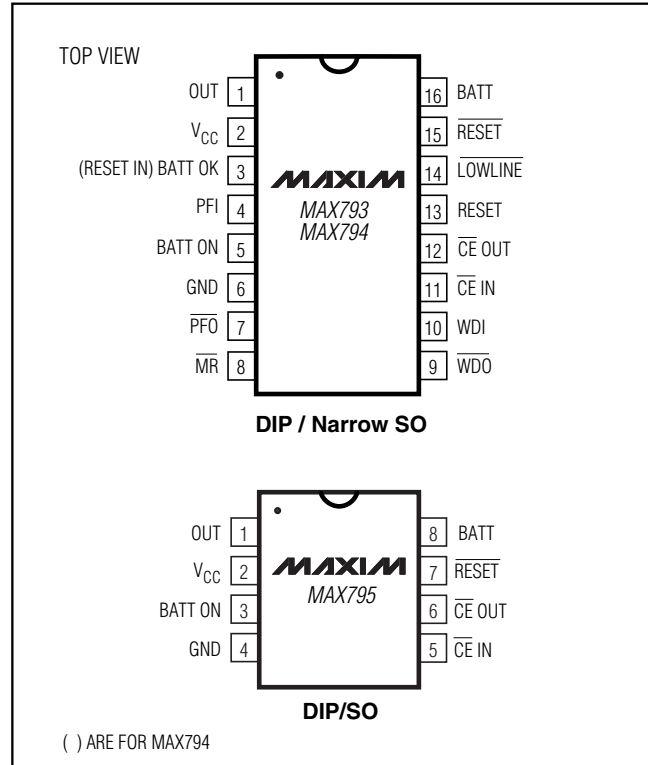

## Chip Information

TRANSISTOR COUNT: 1271

# 3.0V/3.3V Adjustable Microprocessor Supervisory Circuits

## Package Information

(The package drawing(s) in this data sheet may not reflect the most current specifications. For the latest package outline information, go to [www.maxim-ic.com/packages](http://www.maxim-ic.com/packages).)

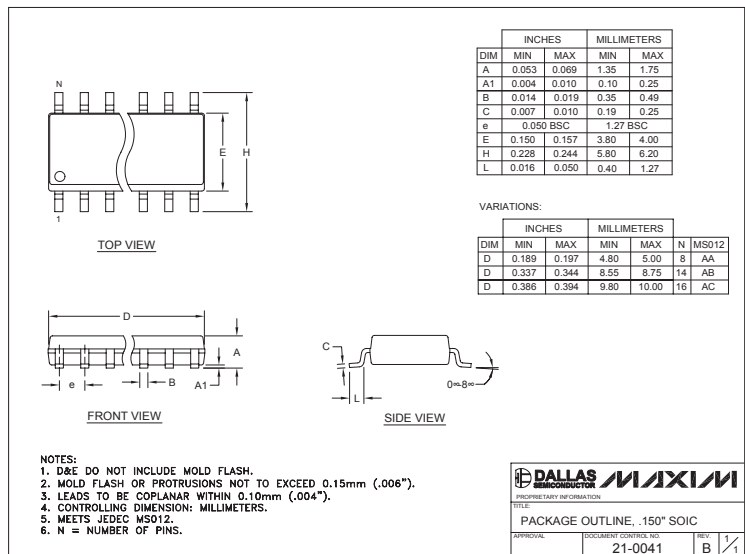
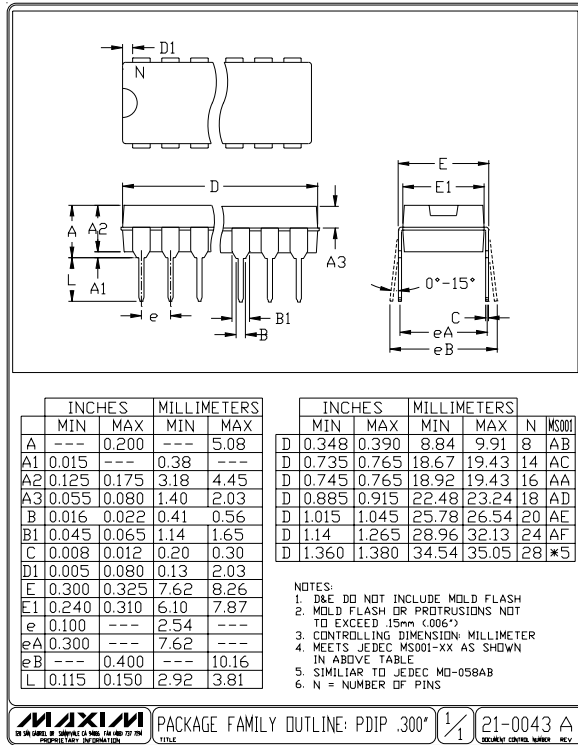

Maxim cannot assume responsibility for use of any circuitry other than circuitry entirely embodied in a Maxim product. No circuit patent licenses are implied. Maxim reserves the right to change the circuitry and specifications without notice at any time.

20 Maxim Integrated Products, 120 San Gabriel Drive, Sunnyvale, CA 94086 408-737-7600