

# FC SERIES ELECTRONIC INTEGRATOR

DATA SHEET

PKH

This electronic integrator receives analog or pulse signals and performs 6-digit LED's integration display. The instrument offers high reliability since it has no moving parts.

## FEATURES

1. The indicator uses large 6-digit LED's which are easy to read.
2. The instrument accepts either analog or pulse signal input.
3. A number of optional functions such as BCD transmission and pulse transmission are available, so the integration can be readily used for remote transmission or connected with a computer.

## SPECIFICATIONS

**Input signal:** Analog input;  
 1 to 5V DC (input resistance 1MΩ min.)  
 4 to 20mA DC  
 (input resistance 250Ω)

Pulse input;  
 No-voltage NO contact or transistor open collector connection  
 Output current, 2mA max.  
 Voltage when ON, 0.6V or less  
 Voltage when OFF, 4.5V or more  
 Ton, Toff ≥ 66.7 msec.

**Accuracy:** Analog input;  
 Rated value ±0.5% ±1 digit  
 Rated value means the theoretical value to be obtained when 100% input is continuously applied and integrated.

Pulse input; ±1 digit

**Indication method:**  
 Decimal 6-digit LED's (No indication for zero "0" in higher digits)

**Size of numerals:**  
 Approx. 7.5mm high

**Integration cutoff:**  
 No cutoff or 10% cutoff, selectable (Cutoff function works via cutoff switch inside instrument.)  
 Cut point accuracy;  
 +0  
 -0.5% of input value full scale  
 Hysteresis; 1% max.



### Integration constants:

Analog input  
 1-hour integration value with 100% input  
 Standard integration constants are;  
 50, 100, 200, 250, 300, 400  
 500, 600, 750, 800, 900, 1000  
 1200, 1500, 1600, 1800, 2000, 3000  
 4000, 6000, 8000

(An optical integer from 20 to 9999 can be used as a constant when so specified.)

### Pulse input

Input pulses integrated on 1 : 1 base

**Reset method:** Zero resetting possible with reset push-button switch inside instrument. For model with function for BCD transmission of integrated value, resetting is possible via signal from outside.

**Power supply:** 24V (20 to 30V) DC (or 100V ±10% AC, 50/60Hz is available on request)

### Power consumption:

Approx. 6W at 24V DC, approx. 8VA at 100V AC

### Power indicator lamp:

LED (rectangular type, green)

### Ambient temperature:

0 to 50°C (-30 to +70°C for storage)

**Ambient humidity:**

90%RH or less

**Outline dimensions (HxWxD):**

144 x 72 x 400mm(case) + terminal section

**Mass (weight):** Approx. 4.5kg

**Finish color:** Munsell 7Y 7.3/1.4; frame color of N1.5 is available on request

**Mounting method:**

Panel flash-mount type

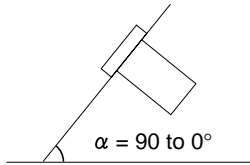

**Optional Functions**

**Protection against power interruption:**

When power is interrupted (including when power switch is OFF), functions such as integration, indication, pulse transmission and BCD transmission are stopped. When power is restored, integration resumes from the value held when the power interruption occurred. This is because a battery serves as a memory backup for retaining the memory contents (integrated value). The battery is effective for about 170 hours or about 7 days (power interruption time).

**Pulse transmission (provided only with analog input):**

Pulses corresponding to the integration constant x 1, x 2, x 5 or x 10 are transmitted outside. Integration constant x 1/2, x 1/5, or x 1/10 is also available.

Contact make time; 80 to 200 msec

Kinds of pulses

No-contact pulse (semiconductor contact output)

Output contact, NPN transistor open collector

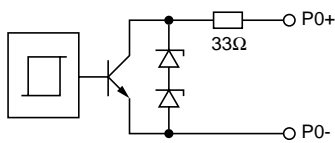

Contact capacity; 33V DC, 50mA max.  
5V DC, 1mA min.

Withstand voltage, 500V AC for 1 minute between PO- and ground  
33V DC between PO+ and PO-

Relay contact (not possible when power failure protection provided)

Output contact; NO contact  
Contact capacity; 100V AC, 0.3A/24V DC, 02A (resistive load)

Withstand voltage; 1000V AC for 1 minute between contacts and ground

**Parallel connection for BCD transmission (negative logic):**

The BCD outputs of multiple integrators can be connected in parallel and changed over and measured via an external device.

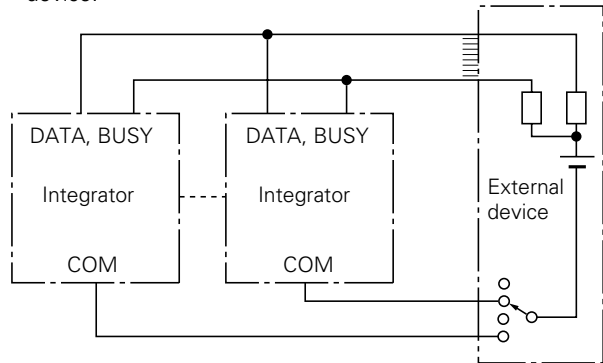

(Caution is necessary at the external device when using RESET/ENABLE, please consult with Fuji.)

**Integrated value transmission:**

Integrated value is transmitted outside in BCD code. A signal which can be read out is simultaneously transmitted. When ENABLE signal of "L" level from outside is input, the value in the output register is held and there is no change in the output. When the internal data are undergoing change, a BUSY signal is transmitted (does not affect the ENABLE signal).

Kinds of signals

- o DATA; BCD 6 digits, parallel output
- o BUSY; Conversion in progress, H or L level selectable; at high impedance when integrator power interrupted (transistor OFF)
- o ENABLE; Signal from outside; output value remains unchanged when at L level
- o COM; 0V
- o RESET; Reset signal from outside; counter is reset when at L level

Kinds of DATA outputs (one kind should be specified)

- o Transistor output negative logic (output is "L" level when internal data "H")

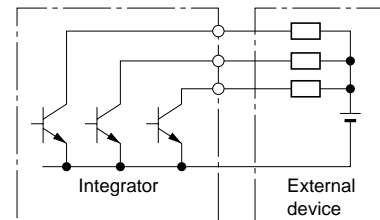

- o Transistor output positive logic (output is "H" level when internal data "H")

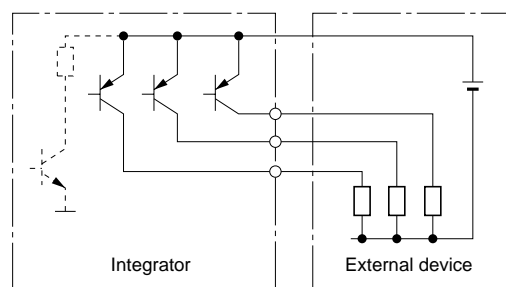

Output rating (DATA, BUSY)

o Negative logic (NPN transistor emitter (-) common, collector output)

"L" equals  $1.1V/I_{max.}$  or less, input current ( $I_{max.}$ ) equal to 30mA

"H" equals applied voltage +5 to 33V, leakage current  $20\mu A$  or less (at 33V)

o Positive logic (PNP transistor emitter (+) common, collector output)

"L" equals transistor OFF, leakage current  $20\mu A$  or less

(at 33V)

"H" equals applied voltage +1.5V, output current ( $I_{max.}$ ) equal to 30mA

Input rating (ENABLE, RESET)

o "L" level equals 1.1V max., output current 0.5mA max., or no-voltage contact ON

"H" level equal to 5V min., 33V max., or no-voltage contact OFF

Cable length; 500m max.

Outline of timing (see interface timing on next page for details)

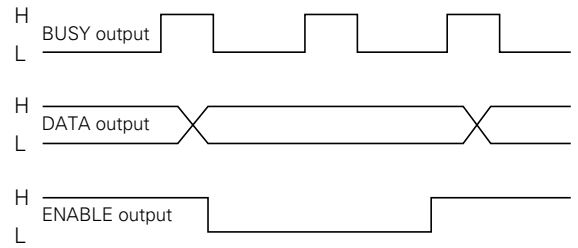

Example of interface

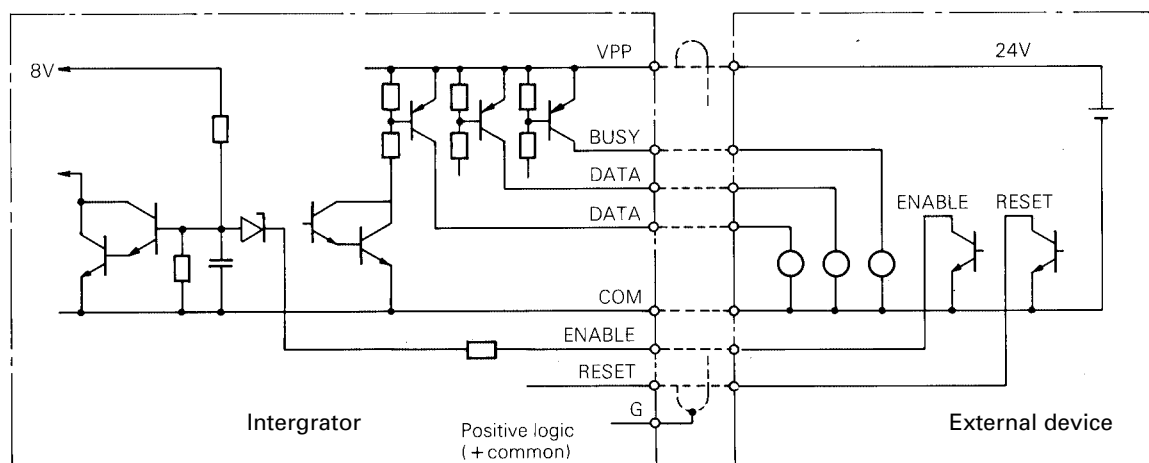
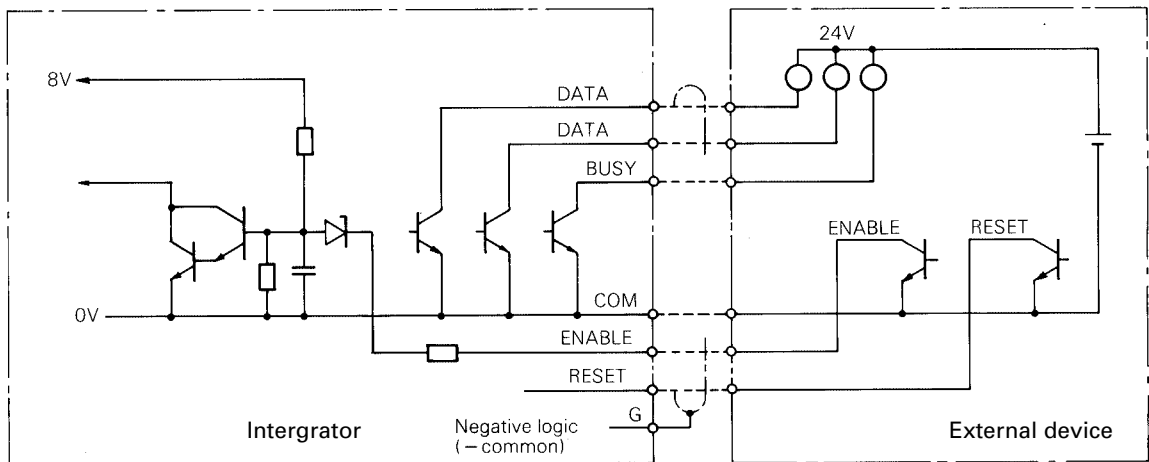

# FUNDAMENTAL PRINCIPLE DIAGRAM

## With analog input

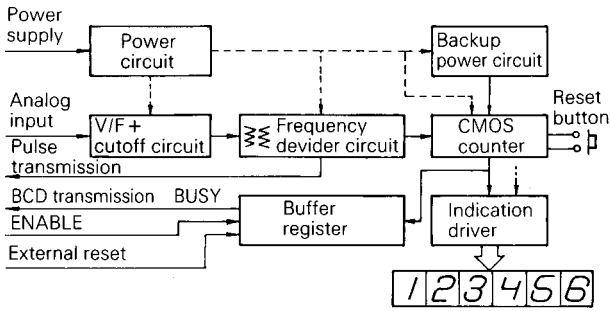

## With pulse input

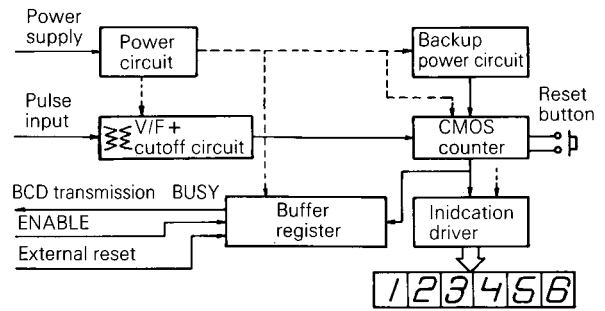

## Interface timing

### Negative logic interface timing

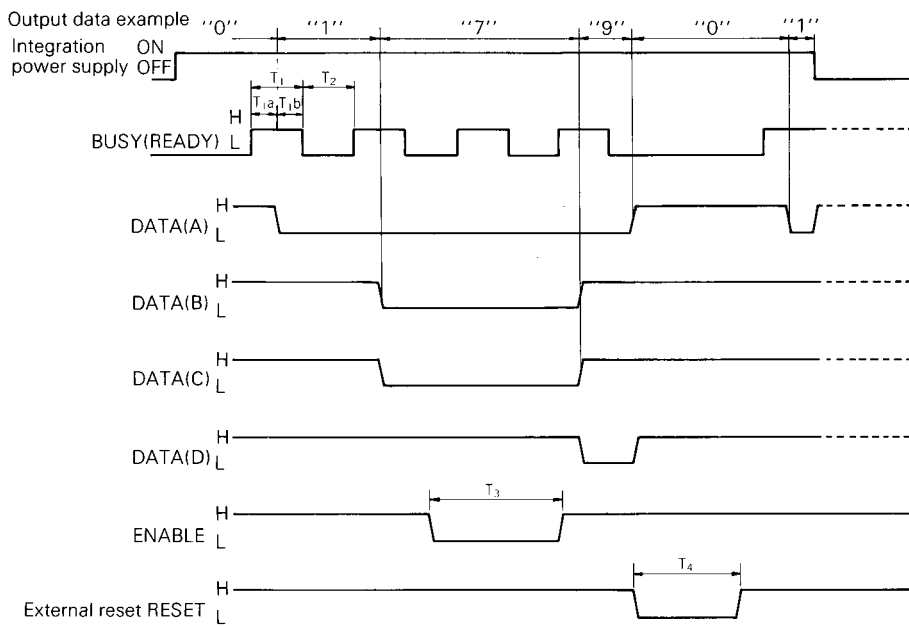

### Positive logic interface timing

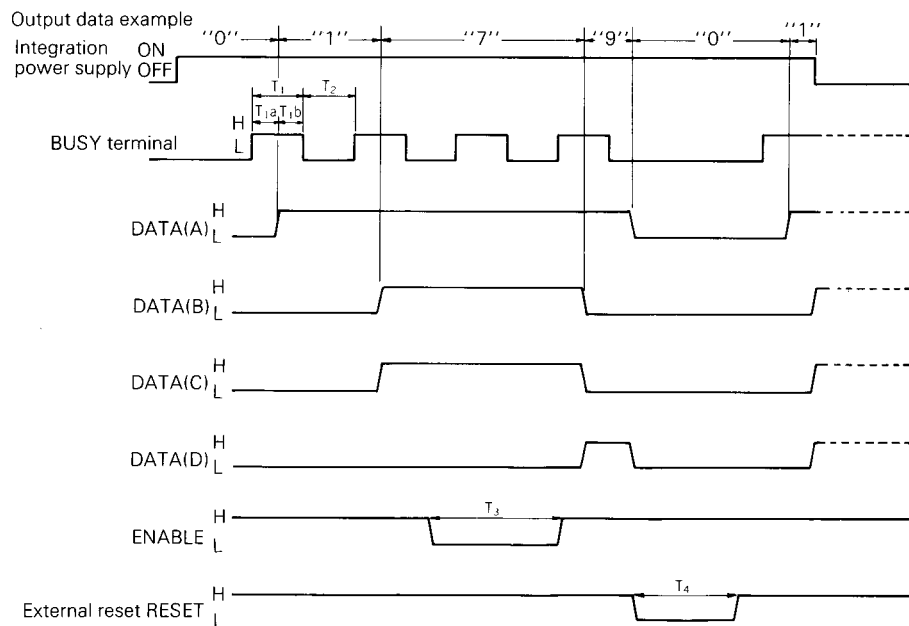

$T_1, T_2 = 150\text{ms}$                        $T_3$ : no limiting  
 $T_{1a}, T_{1b} = T_1/2$                        $T_4$ : 20ms minimum  
 --- = high impedance

# CODE SYMBOLS

Description																																																																			
1	P	K	H										<b>Input signal</b> Analog input, 1 to 5V DC Analog input, 4 to 20mA DC Pulse input, counter works at ON Pulse input, counter works at OFF																																																						
	A												<b>Accuracy</b> General-use type $\pm 0.5\%$																																																						
	B												<b>Integration constant</b> (1-hour integrated value with 100% input) Specify Y with pulse input <table border="1"> <thead> <tr> <th>Code</th><th>Integral</th><th>Code</th><th>Integral</th><th>Code</th><th>Integral</th></tr> </thead> <tbody> <tr><td>V</td><td>50</td><td>J</td><td>750</td><td>U</td><td>2000</td></tr> <tr><td>W</td><td>100</td><td>K</td><td>800</td><td>H</td><td>3000</td></tr> <tr><td>A</td><td>200</td><td>L</td><td>900</td><td>P</td><td>4000</td></tr> <tr><td>B</td><td>250</td><td>M</td><td>1000</td><td>Q</td><td>6000</td></tr> <tr><td>C</td><td>300</td><td>N</td><td>1200</td><td>D</td><td>8000</td></tr> <tr><td>E</td><td>400</td><td>R</td><td>1500</td><td>Z</td><td>Other than above, but within 20 to 9999</td></tr> <tr><td>F</td><td>500</td><td>S</td><td>1600</td><td>Y</td><td>with pulse input</td></tr> <tr><td>G</td><td>600</td><td>T</td><td>1800</td><td></td><td></td></tr> </tbody> </table>	Code	Integral	Code	Integral	Code	Integral	V	50	J	750	U	2000	W	100	K	800	H	3000	A	200	L	900	P	4000	B	250	M	1000	Q	6000	C	300	N	1200	D	8000	E	400	R	1500	Z	Other than above, but within 20 to 9999	F	500	S	1600	Y	with pulse input	G	600	T	1800		
Code	Integral	Code	Integral	Code	Integral																																																														
V	50	J	750	U	2000																																																														
W	100	K	800	H	3000																																																														
A	200	L	900	P	4000																																																														
B	250	M	1000	Q	6000																																																														
C	300	N	1200	D	8000																																																														
E	400	R	1500	Z	Other than above, but within 20 to 9999																																																														
F	500	S	1600	Y	with pulse input																																																														
G	600	T	1800																																																																
	Z																																																																		
													<b>Power supply</b> 24V DC 100V AC, 50/60Hz																																																						
													<b>Protection against power interruption</b> Battery backup provided None																																																						
													<b>Pulse transmission</b> (Specify Y with pulse input) <table border="1"> <thead> <tr> <th>Contact</th><th>*Relay contact</th><th>No contact</th></tr> </thead> <tbody> <tr> <td>Multiple</td><td></td><td></td></tr> <tr> <td>x1</td><td>A</td><td>J</td></tr> <tr> <td>x2</td><td>B</td><td>K</td></tr> <tr> <td>x5</td><td>C</td><td>L</td></tr> <tr> <td>x10</td><td>D</td><td>M</td></tr> <tr> <td>x1/2</td><td>N</td><td>U</td></tr> <tr> <td>x1/5</td><td>P</td><td>V</td></tr> <tr> <td>x1/10</td><td>Q</td><td>W</td></tr> <tr> <td>None</td><td>Y</td><td></td></tr> </tbody> </table> *When battery back-up is provided, relay contact output cannot be equipped.	Contact	*Relay contact	No contact	Multiple			x1	A	J	x2	B	K	x5	C	L	x10	D	M	x1/2	N	U	x1/5	P	V	x1/10	Q	W	None	Y																									
Contact	*Relay contact	No contact																																																																	
Multiple																																																																			
x1	A	J																																																																	
x2	B	K																																																																	
x5	C	L																																																																	
x10	D	M																																																																	
x1/2	N	U																																																																	
x1/5	P	V																																																																	
x1/10	Q	W																																																																	
None	Y																																																																		
													<b>Integrated value transmission</b> BCD transmission (negative logic) BCD transmission (positive logic) None																																																						
													<b>Optional function (1)</b> BCD transmission (negative logic) Parallel connection None																																																						
														<b>Optional function (2)</b> None																																																					

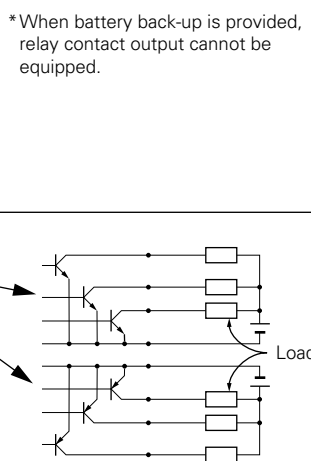

## Manufacturable range for pulse transmission

Multiple \ Constant	x 1/10	x 1/5	x 1/2	x 1	x 2	x 5	x 10
	50 or less	x	x				
100	x	x					
200	x						
250							
∧	Manufacturing range						
2000							x
3000							x
4000							x
6000						x	x
8000						x	x
below 10000						x	x

# OUTLINE DIAGRAM (Unit : mm)

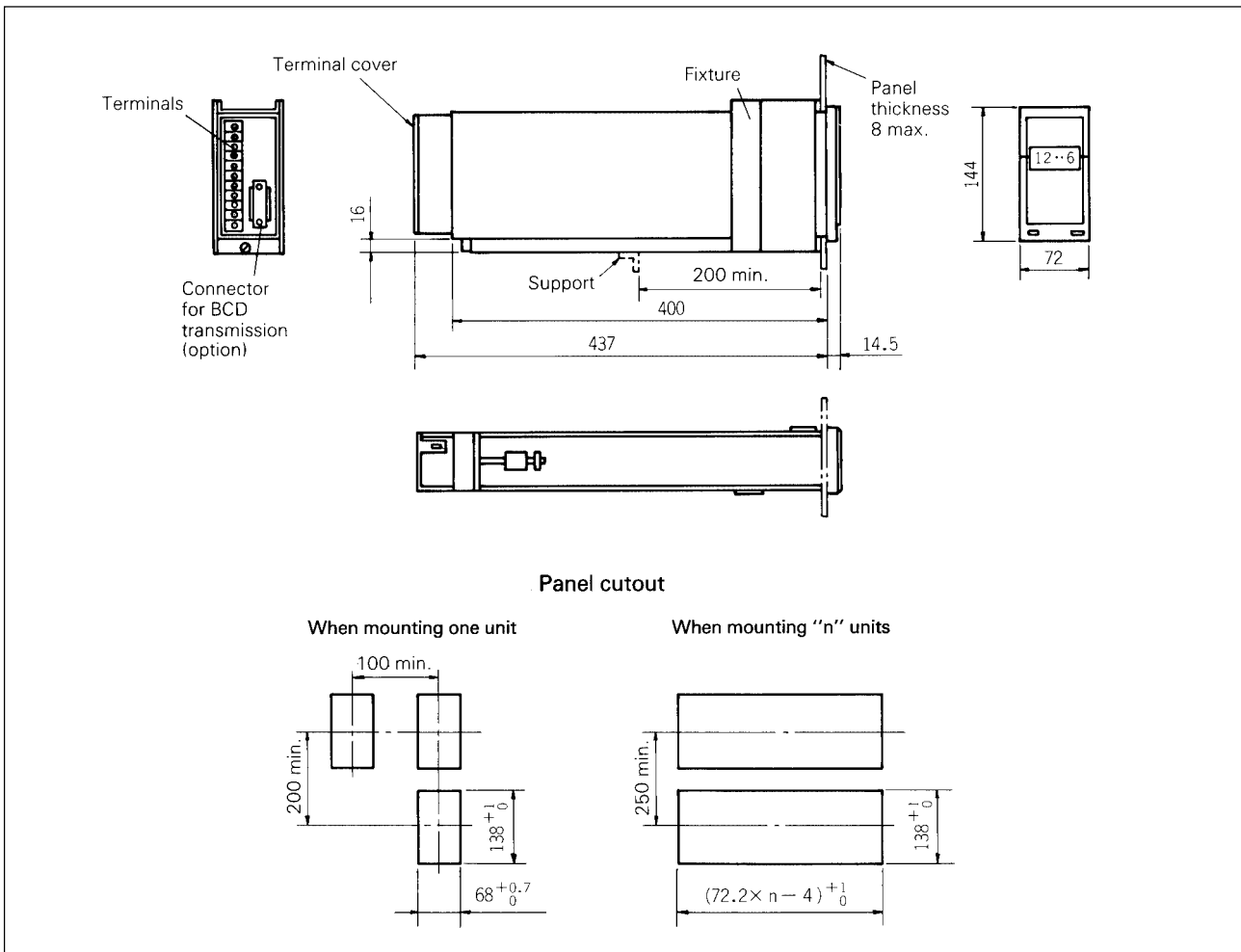

# CONNECTION DIAGRAM

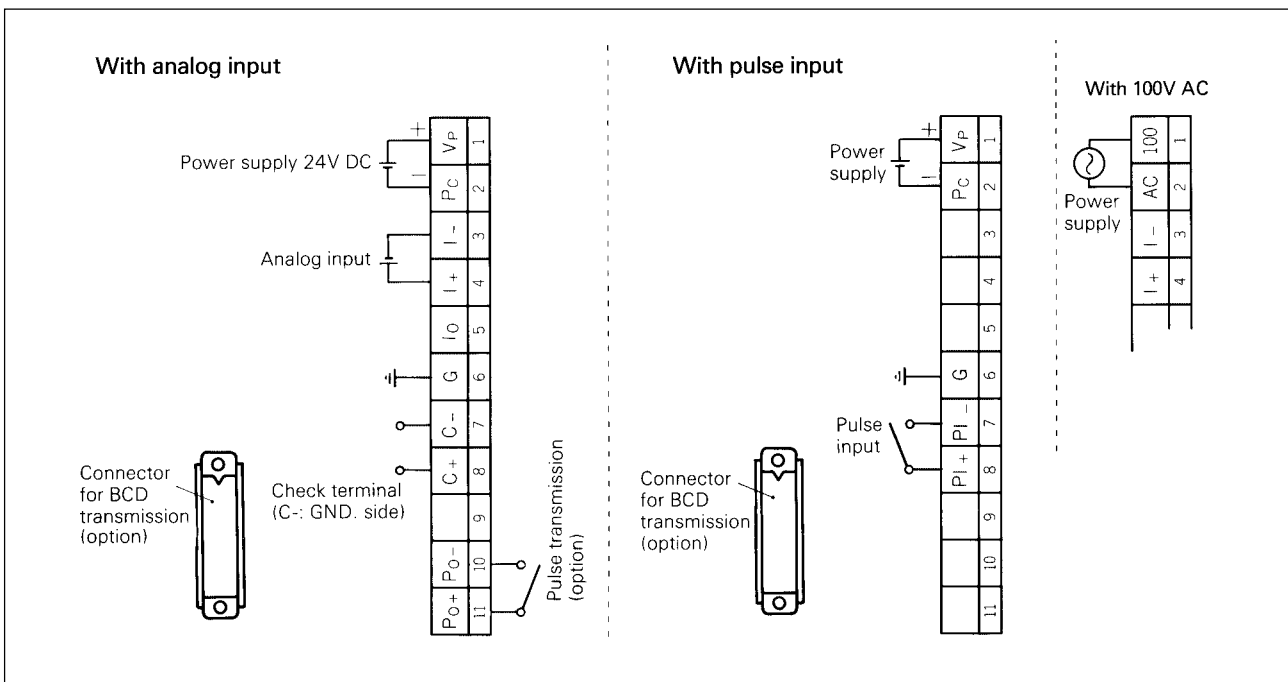

### BCD output connector (option)

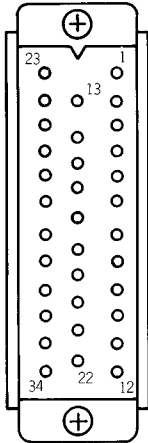

Terminal No.	Signal name	Terminal No.	Signal name	Terminal No.	Signal name
1	A <sub>1</sub>	13	A <sub>3</sub>	23	A <sub>5</sub>
2	B <sub>1</sub>	14	B <sub>3</sub>	24	B <sub>5</sub>
3	C <sub>1</sub>	15	C <sub>3</sub>	25	C <sub>5</sub>
4	D <sub>1</sub>	16	D <sub>3</sub>	26	D <sub>5</sub>
5	A <sub>2</sub>	17	A <sub>4</sub>	27	A <sub>6</sub>
6	B <sub>2</sub>	18	B <sub>4</sub>	28	B <sub>6</sub>
7	C <sub>2</sub>	19	C <sub>4</sub>	29	C <sub>6</sub>
8	D <sub>2</sub>	20	D <sub>4</sub>	30	D <sub>6</sub>
9		21	COM	31	
10	BUSY	22	COM	32	G (shield)
11	RESET			33	VPP
12	ENABLE			34	VPP

Connector used: MC-34SBMG (Supplier: Honda Communication Industries Co., Ltd., Japan)

Note:

$$A(i) = 2^0$$

$$B(i) = 2^1$$

$$C(i) = 2^2$$

$$D(i) = 2^3$$

Digit

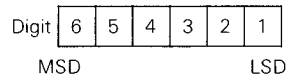

## SCOPE OF DELIVERY

Integrator and mounting fixtures

Output connector when BCD transmission provided

⚠ Caution on Safety

\*Before using this product, be sure to read its instruction manual in advance.

---

## Fuji Electric Systems Co., Ltd.

### Head Office

Gate City Ohsaki, East Tower, 11-2, Osaki 1-chome,  
Shinagawa-ku, Tokyo 141-0032, Japan

<http://www.fesys.co.jp/eng>

### Instrumentation Div.

#### International Sales Dept.

No.1, Fuji-machi, Hino-city, Tokyo, 191-8502 Japan

Phone: 81-42-585-6201, 6202 Fax: 81-42-585-6187

<http://www.fic-net.jp/eng>

---

Information in this catalog is subject to change without notice.

Printed in Japan