

Spec. No.	413-212-105
Doc. version :	0
Total pages :	19
Date :	2001.10.15

Distributed by



An Axess Technology Group company

Joseph-Fraunhofer-Str. 41
D-85276 Pfaffenhofen
Tel: +49 (0) 8441 5042-0
Fax: +49 (0) 8441 5042-27

www.aaronn.de
www.axess-technology.com

Aaronn makes no warranty for errors
which may appear in this document.

Product Specification

2.5" COLOR TFT-LCD MODULE

MODEL NAME: A025CN01 Ver.3 (UP025D11-3)

< ◆ > Preliminary Specification
< > Final Specification

Note: The content of this
specification is subject to
change.

© 2001 AU Optronics
All Rights Reserved,
Do Not Copy.

Contents:

A. Physical specifications	P3
B. Electrical specifications	P4
1. Pin assignment.....	P4
a. TFT-LCD panel driving section.....	P4
b. Backlight driving section.....	P5
2. Absolute maximum ratings.....	P5
3. Electrical characteristics.....	P6
a. Typical operating conditions.....	P6
b. Current consumption.....	P6
c. Backlight driving conditions.....	P6
4. AC Timing.....	P7
a. Timing conditions.....	P7
b. Timing diagram.....	P7
C. Optical specifications	P8
D. Reliability test items	P10
E. Packing form	P11

Appendix:

Fig.1 Outline dimension of TFT-LCD module..... **P12**
Fig.2 Sampling clock timing..... **P13**
Fig.3 Horizontal display timing range **P14**
Fig.4-(a) Horizontal timing..... **P15**
Fig.4-(b) Detail horizontal timing..... **P16**
Fig.5 Vertical shift clock timing..... **P17**
Fig.6-(a) Vertical timing (From up to down)..... **P18**
Fig.6-(b) Vertical timing (From down to up) **P19**

A. Physical specifications

NO.	Item	Specification	Remark
1	Display resolution(dot)	480(W)×234(H)	
2	Active area(mm)	49.2(W)×38.142(H)	
3	Screen size(inch)	2.45(Diagonal)	
4	Dot pitch(mm)	0.1025(W)×0.163(H)	
5	Color configuration	R. G. B. delta	
6	Overall dimension(mm)	58.8(W)×49.9(H)×5.7(D)	Note 1
7	Weight(g)	25±5	

Note 1: Refer to Fig. 1

Distributed by



An Axess Technology Group company

Joseph-Fraunhofer-Str. 41
D-85276 Pfaffenhofen
Tel: +49 (0) 8441 5042-0
Fax: +49 (0) 8441 5042-27

www.aaronn.de
www.axess-technology.com

Aaronn makes no warranty for errors
which may appear in this document.

B. Electrical specifications

1.Pin assignment

a. TFT-LCD panel driving section

Pin no	Symbol	I/O	Description	Remark
1	STHL	I/O	Start pulse for horizontal scan line	Note 1
2	OEH	I	Output enable input for data driver	
3	Q1H	I	Analog signal rotate input	
4	CPH1	I	Sampling and shifting clock pulse for data driver	
5	CPH2	I	Sampling and shifting clock pulse for data driver	
6	CPH3	I	Sampling and shifting clock pulse for data driver	
7	GND	-	Ground	
8	VB	I	Alternated video signal input(Blue)	
9	VG	I	Alternated video signal input(Green)	
10	VR	I	Alternated video signal input(Red)	
11	NC	-	This pin should be electrical opened during operation	
12	L/R	I	Left/Right scan control input	Note 1,2
13	STHR	I/O	Start pulse for horizontal scan line	Note 1
14	AV _{DD}	I	Supply voltage for analog circuit	
15	VCOM	I	Common electrode driving signal	
16	V _{GH}	I	Positive power for scan driver	
17	V _{CC}	I	Logic power for scan & data driver	
18	STVL	I/O	Vertical start pulse	Note 1
19	OEV	I	Output enable input for scan driver	
20	CKV	I	Shift clock input for scan driver	
21	U/D	I	UP/DOWN scan control input	Note 1,2
22	STVR	I/O	Vertical start pulse	Note 1
23	NC	-	This pin should be electrical opened during operation	
24	V _{GL}	I	Negative power for scan driver	

Note 1 : Selection of scanning mode

Setting of scan control input		IN/OUT state For start pulse				Scanning direction
U/D	L/R	STVR	STVL	STHR	STHL	
GND	V _{CC}	OUT	IN	OUT	IN	From up to down, and from left to right.
V _{CC}	GND	IN	OUT	IN	OUT	From down to up, and from right to left.
GND	GND	OUT	IN	IN	OUT	From up to down, and from right to left.
V _{CC}	V _{CC}	IN	OUT	OUT	IN	From down to up, and from left to right.

IN: Input; OUT: Output.

Note 2 : Definition of scanning direction.

Refer to figure as below:

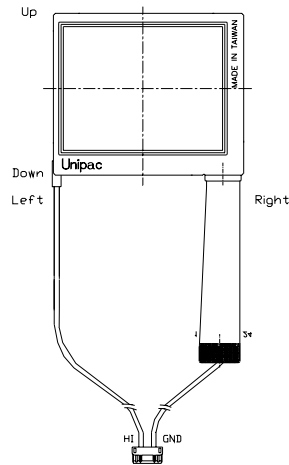

b. Backlight driving section (Refer to Fig.1)

No.	Symbol	I/O	Description	Remark
1	HI	I	Power supply for backlight unit (High voltage)	
2	GND	-	Ground	

2. Absolute maximum ratings

Item	Symbol	Condition	Min.	Max.	Unit	Remark
Power voltage	V _{CC}	GND=0	-0.3	7	V	
	AV _{DD}	AV _{SS} =0	-0.3	7	V	
	V _{GH}	GND=0	-0.3	18	V	
	V _{GL}		-18	0.3	V	
	V _{GH} -V _{GL}		-	36	V	
Input signal voltage	V _i		-0.3	AV _{DD} +0.3	V	Note 1
	V _i		-0.3	V _{CC} +0.3	V	Note 2
	V _{COM}		-2.9	5.2	V	
Operating temperature	Topa		0	60	°C	Ambient temperature
Storage temperature	Tstg		-25	80	°C	Ambient temperature

Note 1: VR, VG, VB

Note 2: STHL, STHR, Q1H,OEH,L/R,CPH1~CPH3, STVR, STVL,OEV,CKV,U/D.

3. Electrical characteristics

a. Typical operating conditions (GND=AVss=0V)

Item	Symbol	Min.	Typ.	Max.	Unit	Remark
Power supply	V_{CC}	3	5	5.2	V	
	AV_{DD}	4.8	5	5.2	V	
	V_{GH}	14.3	15	15.7	V	
	V_{GLAC}	3.5	5	7.5	Vp-p	AC component of V_{GL} . Note 1
	V_{GL-H}	-10	-9.5	-9	V	High level of V_{GL} .
Video signal Amplitude (VR,VG,VB)	V_{iA}	$AV_{SS}+0.4$	-	$AV_{DD}-0.4$	V	Note 2
	V_{iAC}	-	3	-	V	AC component
	V_{iDC}	-	$AV_{DD}/2$	-	V	DC component
VCOM	V_{CAC}	3.5	5	7.5	Vp-p	AC component,Note 3
	V_{CDC}	-	1.1	-	V	DC component
Input Signal voltage	H Level	V_{IH}	$0.8 V_{CC}$	-	V_{CC}	Note 4
	L Level	V_{IL}	0	-	$0.2 V_{CC}$	

Note 1: The same phase and amplitude with common electrode driving signal(VCOM).

Note 2: Refer to Fig.4-(a)

Note 3: The brightness of LCD panel could be adjusted by the adjustment of the AC component of VCOM.

Note 4: STHL,STHR,Q1H,OEH,L/R,CPH1~CPH3,STVR,STVL,OEV,CKV,U/D.

Note 5: Be sure to apply GND, V_{CC} , V_{GL} to the LCD first, and then apply V_{GH} .

b. Current consumption (GND=AVss=0V)

Parameter	Symbol	Condition	Min.	Typ.	Max.	Unit	Remark
Current for driver	I_{GH}	$V_{GH}=15V$	-	50	100	μA	
	I_{GL}	$V_{GL-H}=-10V$	-	-0.3	-0.6	mA	
	I_{CC}	$V_{CC}=5V$	-	1.5	4	mA	
	I_{DD}	$AV_{DD}=5V$	-	5	10	mA	

c. Backlight driving conditions

Parameter	Symbol	Min.	Typ.	Max.	Unit	Remark
Lamp voltage	V_L	210	230	250	Vrms	
Lamp current	I_L	2.4	2.7	3.0	mArms	
Frequency	F_L	55	60	65	KHz	Note 3
Lamp starting Voltage	V_S	-	-	460	Vrms	Note 1,4
		-	-	690	Vrms	Note 2,4

Note 1: $T_a = 25^\circ C$

Note 2: $T_a = 0^\circ C$

Note 3: The lamp frequency should be selected as different as possible from display horizontal synchronous signal to avoid interference.

Note 4: For starting the backlight unit, the output voltage of DC/AC's transformer should be larger than the maximum lamp starting voltage.

4. AC Timing

a. Timing conditions

Parameter	Symbol	Min.	Typ.	Max.	Unit.	Remark
Rising time	t_r	-	-	10	ns	Note 1
Falling time	t_f	-	-	10	ns	Note 1
High and low level pulse width	t_{CPH}	299	308	319	ns	CPH1~CPH3
CPH pulse duty	t_{CWH}	40	50	60	%	CPH1~CPH3
CPH pulse delay	t_{C12} t_{C23} t_{C31}	70	$t_{CPH}/3$	$t_{CPH}/2$	ns	CPH1~CPH3
STH setup time	t_{SUH}	35	-	-	ns	STHR,STHL
STH hold time	t_{HDH}	35	-	-	ns	STHR,STHL
STH pulse width	t_{STH}	-	1	-	t_{CPH}	STHR,STHL
STH period	t_H	61.5	63.5	65.5	μs	STHR,STHL
OEH pulse width	t_{OEH}	-	3	-	t_{CPH}	OEH
Sample and hold disable time	t_{DIS1}	-	28	-	t_{CPH}	
OEV pulse width	t_{OEV}	-	12	-	t_{CPH}	OEV
CKV pulse width	t_{CKV}	16	28	40	t_{CPH}	CKV
Clean enable time	t_{DIS2}	-	10	-	t_{CPH}	
Horizontal display start	t_{SH}	-	0	-	$t_{CPH}/3$	
Horizontal display timing range	t_{DH}	-	480	-	$t_{CPH}/3$	
STV setup time	t_{SUV}	400	-	-	ns	STVL,STVR
STV hold time	t_{HDV}	400	-	-	ns	STVL,STVR
STV pulse width	t_{STV}	-	-	1	t_H	STVL,STVR
Horizontal lines per field	t_V	256	262	268	t_H	Note 2
Vertical display start	t_{SV}	-	3	-	t_H	
Vertical display timing range	t_{DV}	-	234	-	t_H	
VCOM rising time	t_{rCOM}	-	-	3	μs	
VCOM falling time	t_{fCOM}	-	-	3	μs	
VCOM delay time	t_{DCOM}	-	-	3	μs	
RGB delay time	t_{DRGB}	-	-	1	μs	

Note 1: For all of the logic signals.

Note 2: Please don't use odd horizontal lines to drive LCD panel for both odd and even fields simultaneously.

b. Timing diagram

Please refer to the attached drawings, from Fig.2 to Fig.6.

C. Optical specification (Note 1, Note 2, Note 3)

Item		Symbol	Condition	Min.	Typ.	Max.	Unit	Remark
Response time	Rise	Tr	$\theta = 0^\circ$	-	20	30	ms	Note 4, 6
	Fall	Tf		-	30	40	ms	
Contrast ratio		CR	At optimized viewing angle	100	150	-		Note 5, 6
Viewing angle	Top		$CR \geq 10$	10	-	-	deg.	Note 6, 7
	Bottom			30	-	-		
	Left			45	-	-		
	Right			45	-	-		
Brightness		Y_L	$\theta = 0^\circ$	200	250	-	nit	Note 8
White chromaticity		X	$\theta = 0^\circ$	0.25	0.3	0.35		Note 8
		y		0.3	0.35	0.4		

Note 1. Ambient temperature = 25°C. and lamp current $I_L = 2.7\text{mA}$.

Note 2. To be measured in the dark room.

Note 3. To be measured at the center area of panel with a viewing cone of 1° by Topcon luminance meter BM-7, after 10 minutes operation.

Note 4. Definition of response time:

The output signals of photodetector are measured when the input signals are changed from "black" to "white" (falling time) and from "white" to "black" (rising time), respectively.

The response time is defined as the time interval between the 10% and 90% of amplitudes. Refer to figure as below.

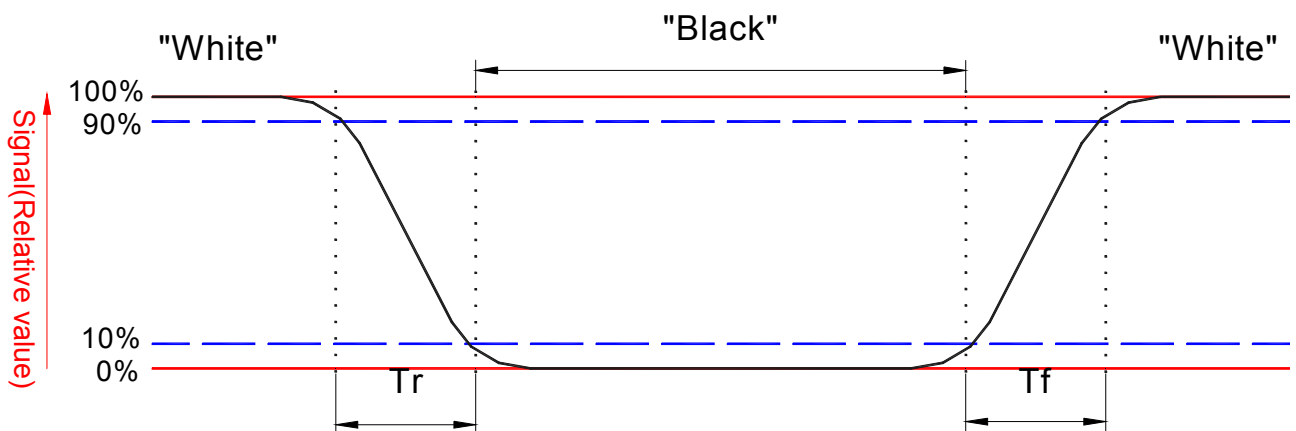

Note 5. Definition of contrast ratio:

Contrast ratio is calculated with the following formula.

$$\text{Contrast ratio (CR)} = \frac{\text{Photodetector output when LCD is at "White" state}}{\text{Photodetector output when LCD is at "Black" state}}$$

Note 6. White $V_i = V_{i50} \mp 1.5V$

Black $V_i = V_{i50} \pm 2.0V$

“±” means that the analog input signal swings in phase with COM signal.

“∓” means that the analog input signal swings out of phase with COM signal.

V_{i50} : The analog input voltage when transmission is 50%

The 100% transmission is defined as the transmission of LCD panel when all the input terminals of module are electrically opened.

Note 7. Definition of viewing angle:

Refer to figure as below.

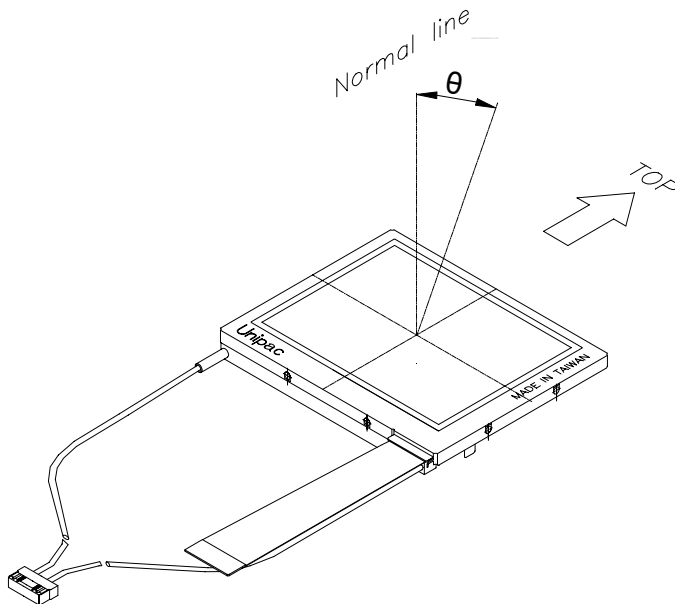

Note 8. Measured at the center area of the panel when all the input terminals of LCD panel are electrically opened.

D. Reliability test items:

No.	Test items	Conditions	Remark
1	High temperature storage	Ta= 80°C 240H	
2	Low temperature storage	Ta= -25°C 240H	
3	High temperature operation	Ta= 60°C 240H	
4	Low temperature operation	Ta= 0°C 240H	
5	High temperature and high humidity	Ta= 60°C . 95% RH 240H	Operation
6	Heat shock	-25°C~80°C/50 cycle 2H/cycle	Non-operation
7	Electrostatic discharge	±200V,200pF(0Ω), once for each terminal	Non-operation
8	Vibration	Frequency range : 10~55Hz Stoke : 1.5mm Sweep : 10~55Hz~10Hz 2 hours for each direction of X,Y,Z (6 hours for total)	JIS C7021, A-10 condition A
9	Mechanical shock	100G . 6ms, ±X,±Y,±Z 3 times for each direction	JIS C7021, A-7 condition C
10	Vibration (with carton)	Random vibration: 0.015G ² /Hz from 5~200Hz -6dB/Octave from 200~500Hz	IEC 68-34
11	Drop (with carton)	Height: 80cm 1 corner, 3 edges, 6 surfaces	

Note: Ta: Ambient temperature.

E.Packing form

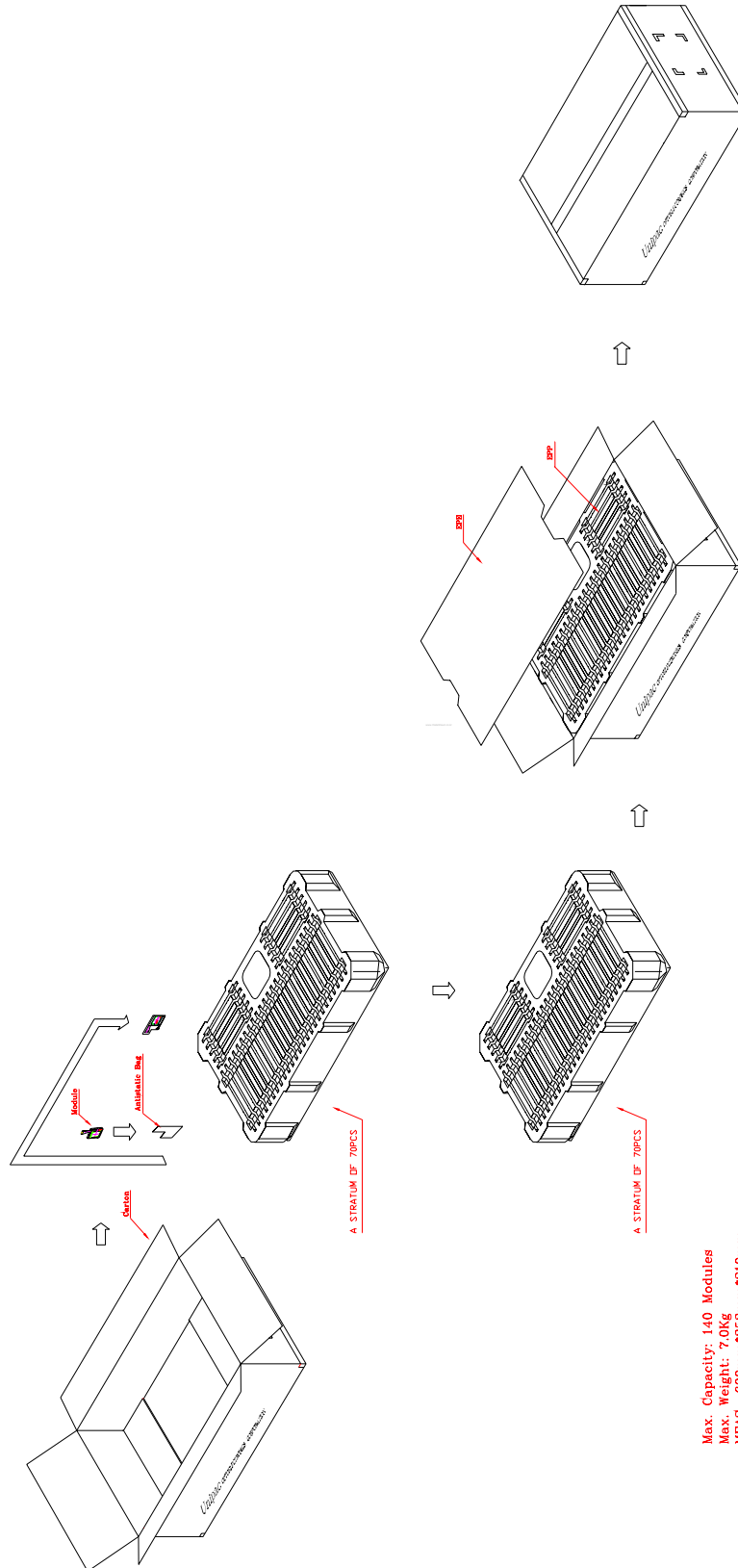

Max. Capacity: 140 Modules
 Max. Weight: 7.0kg
 MEAS.: 600mm*353mm*210mm

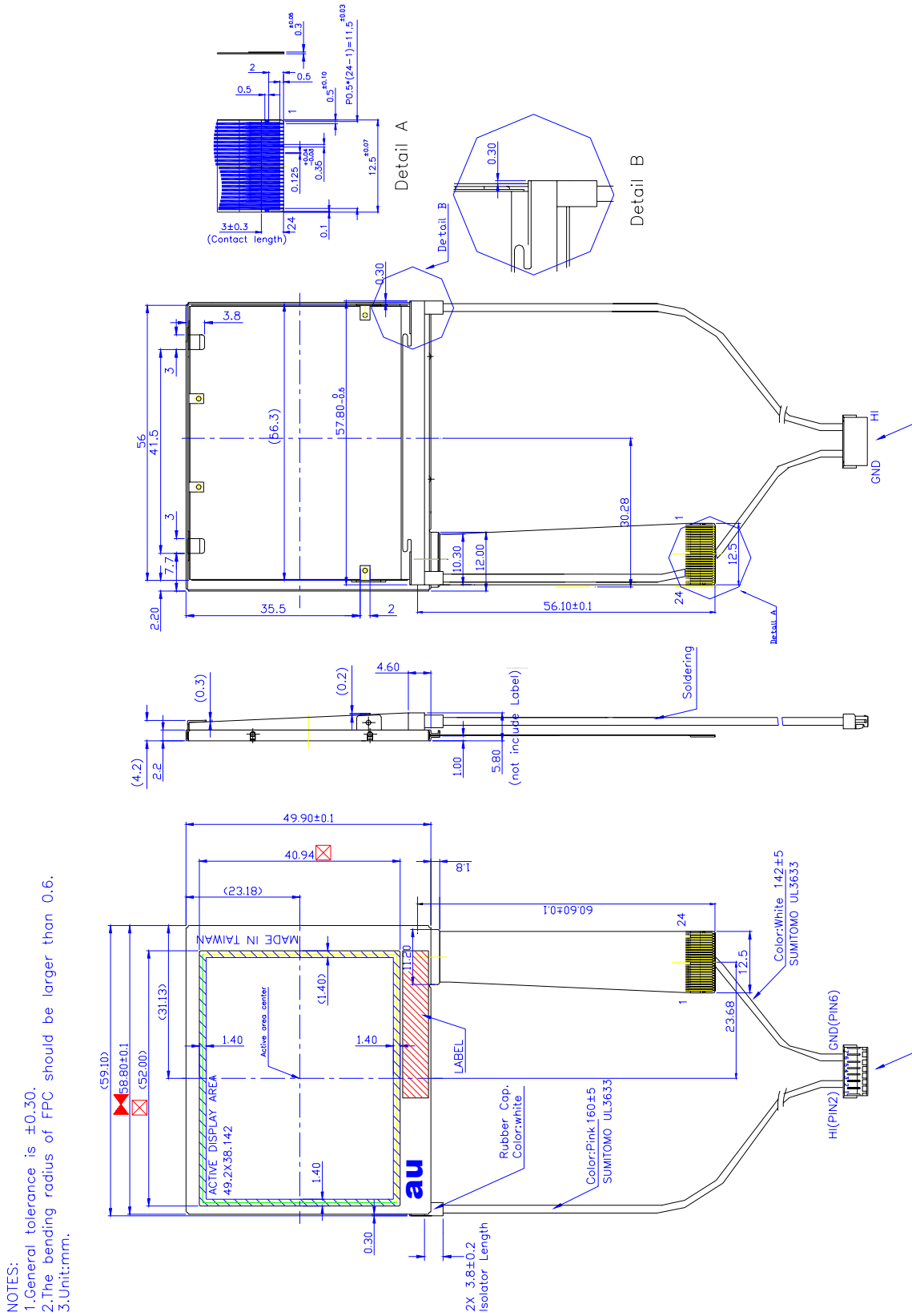

Fig.1 Outline dimension of TFT-LCD module

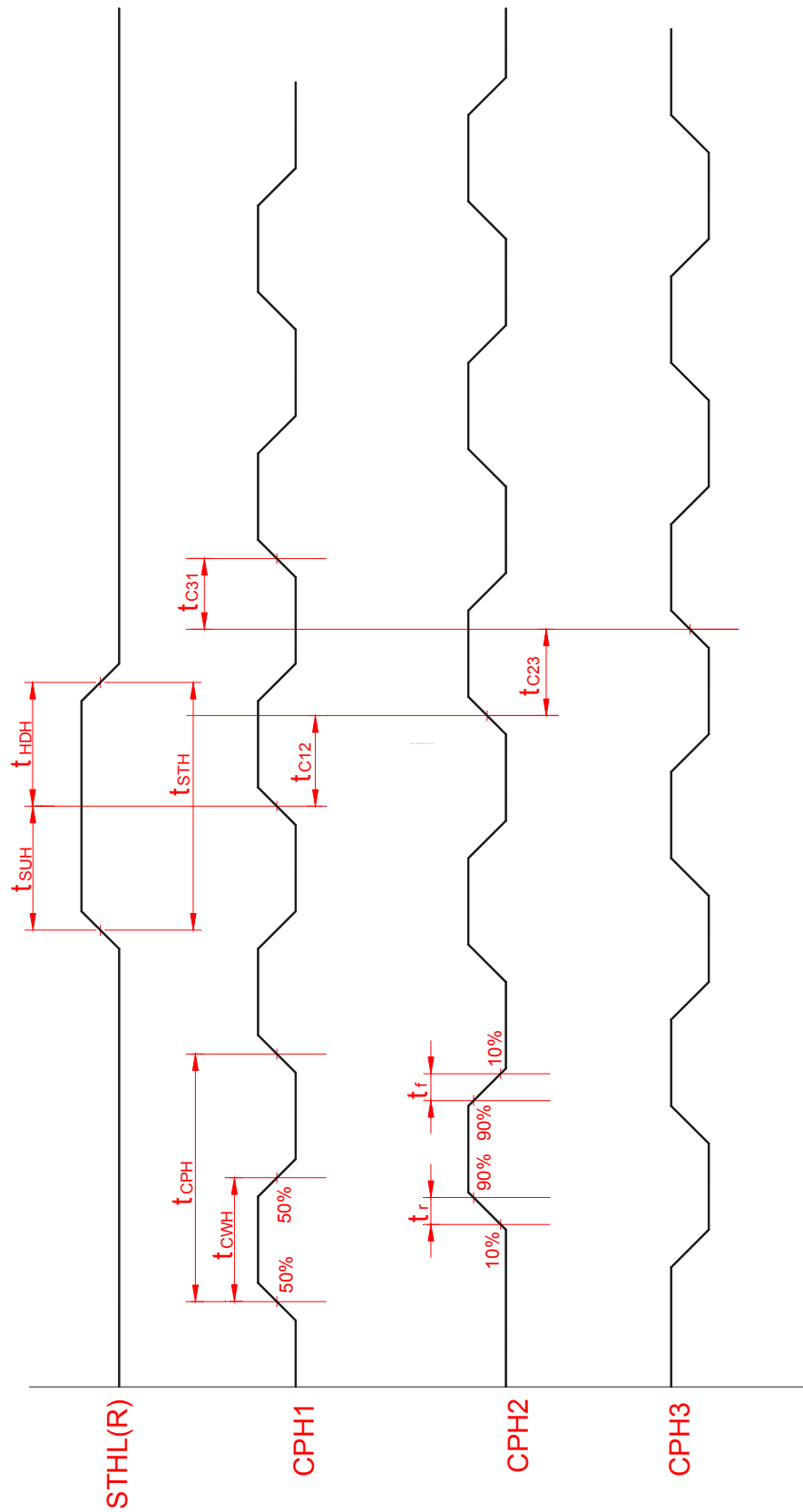

Fig.2 Sampling clock timing

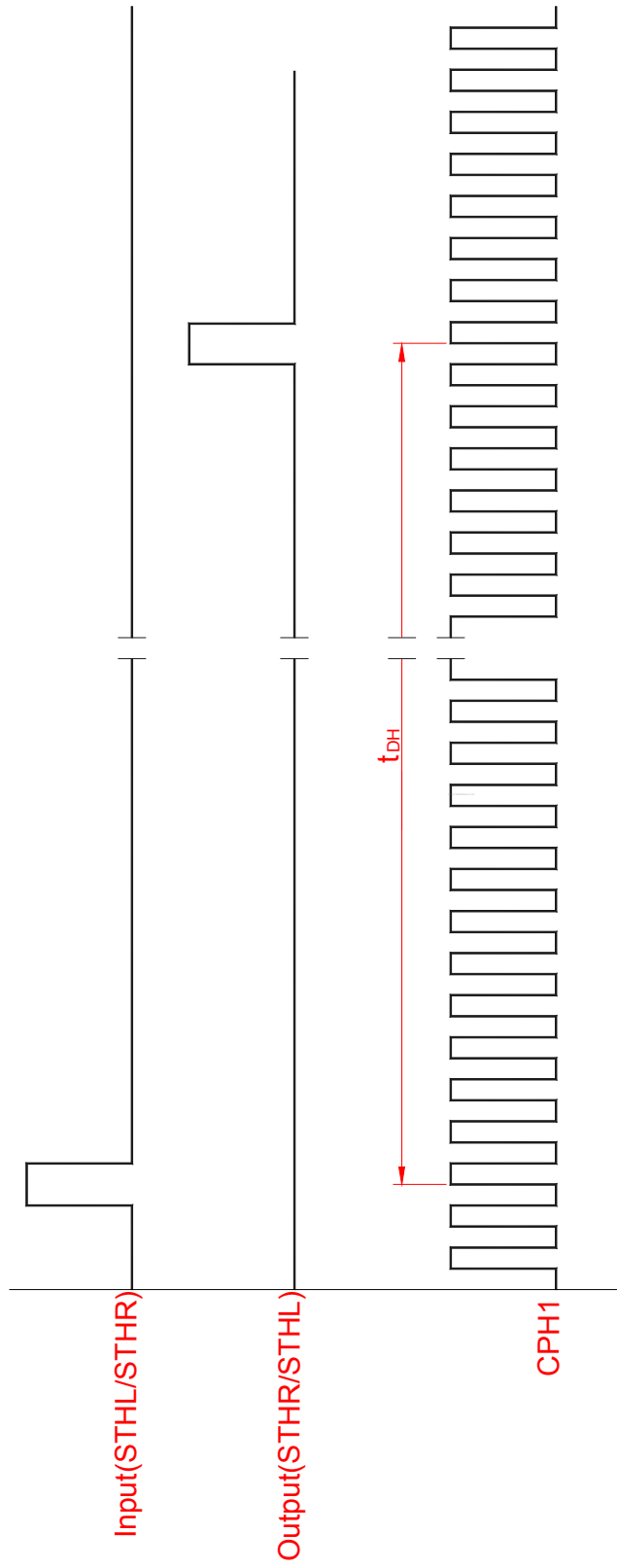

Fig.3 Horizontal display timing range

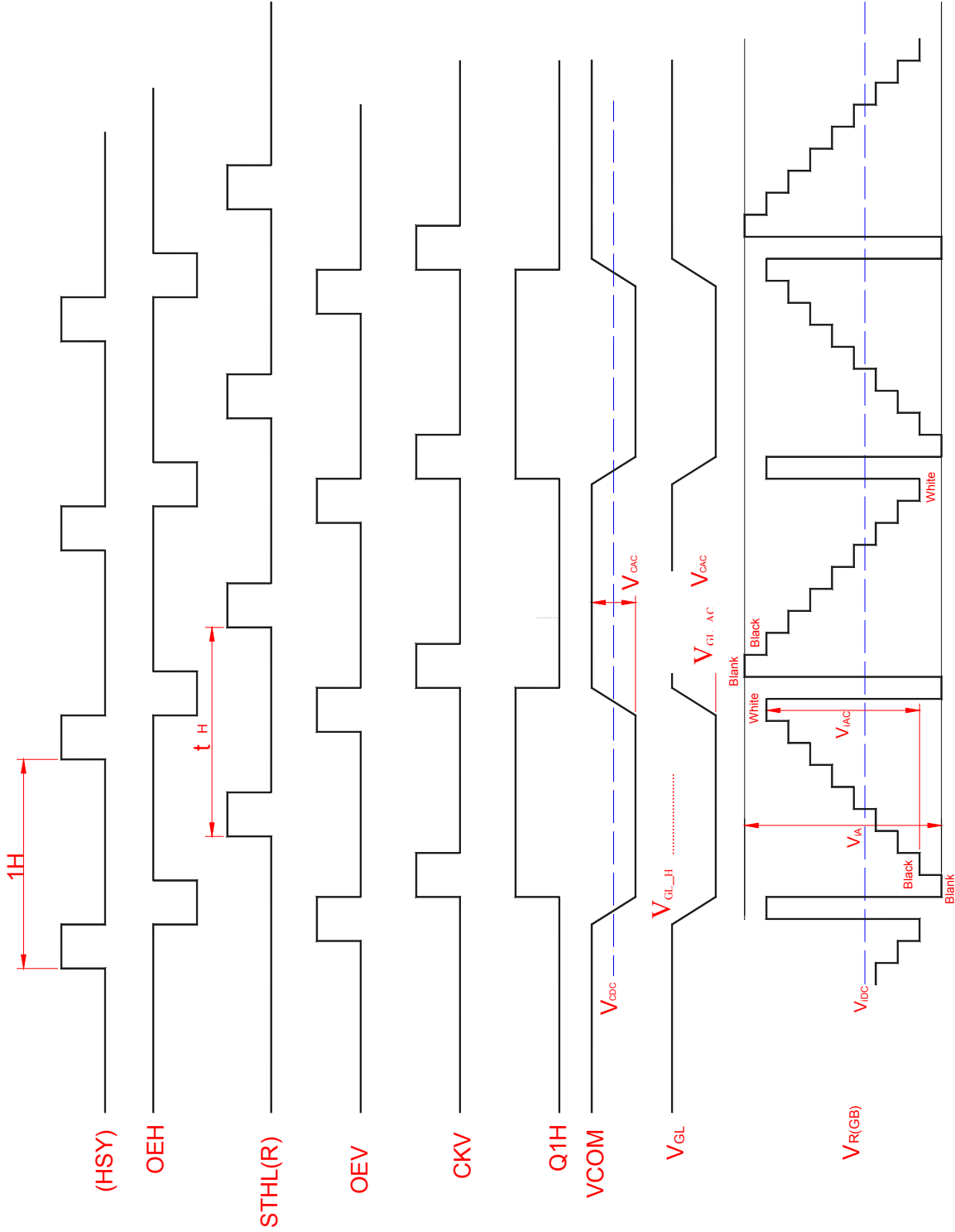

Fig.4(a) Horizontal timing

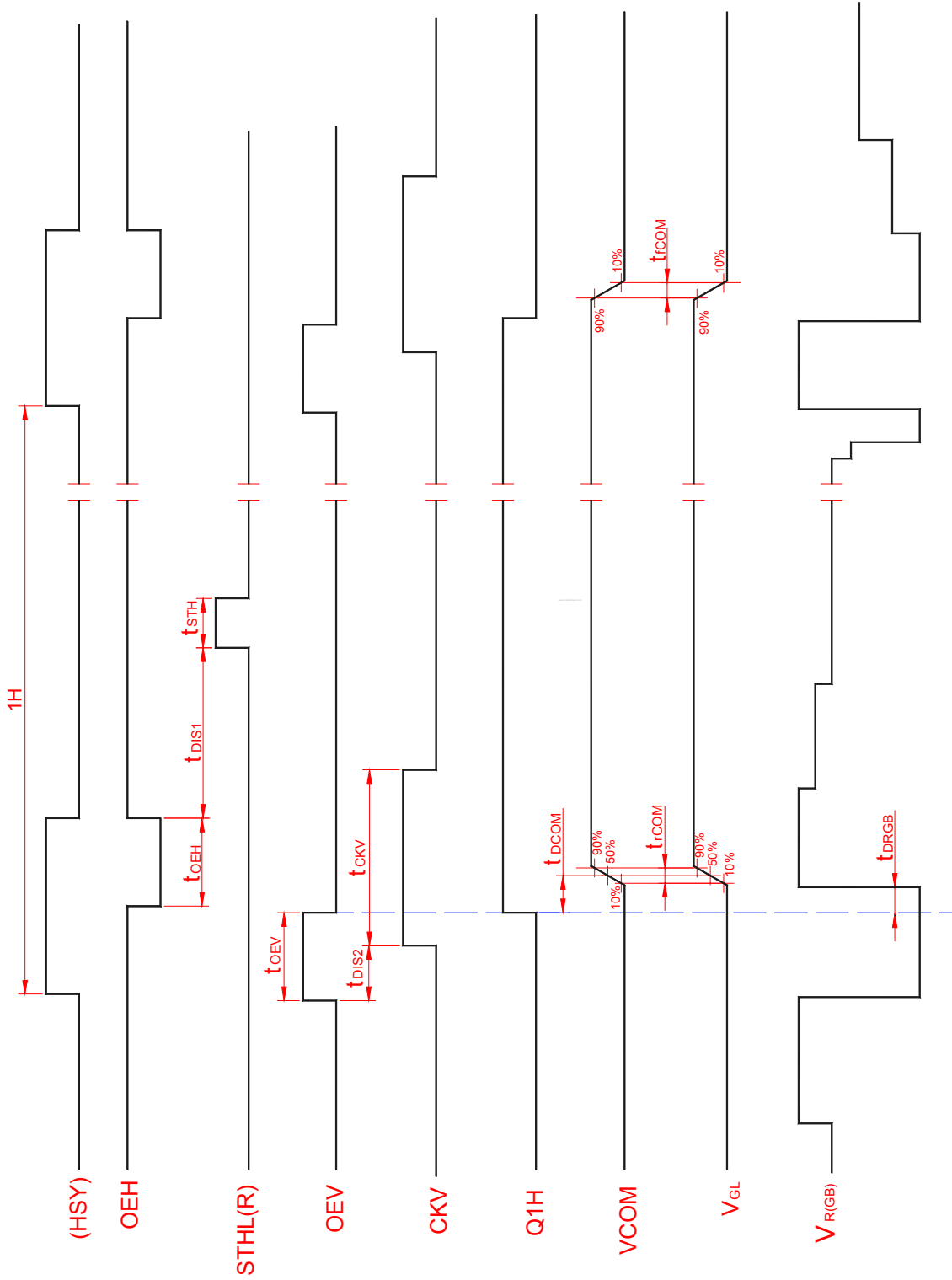

Fig.4-(b) Detail horizontal timing

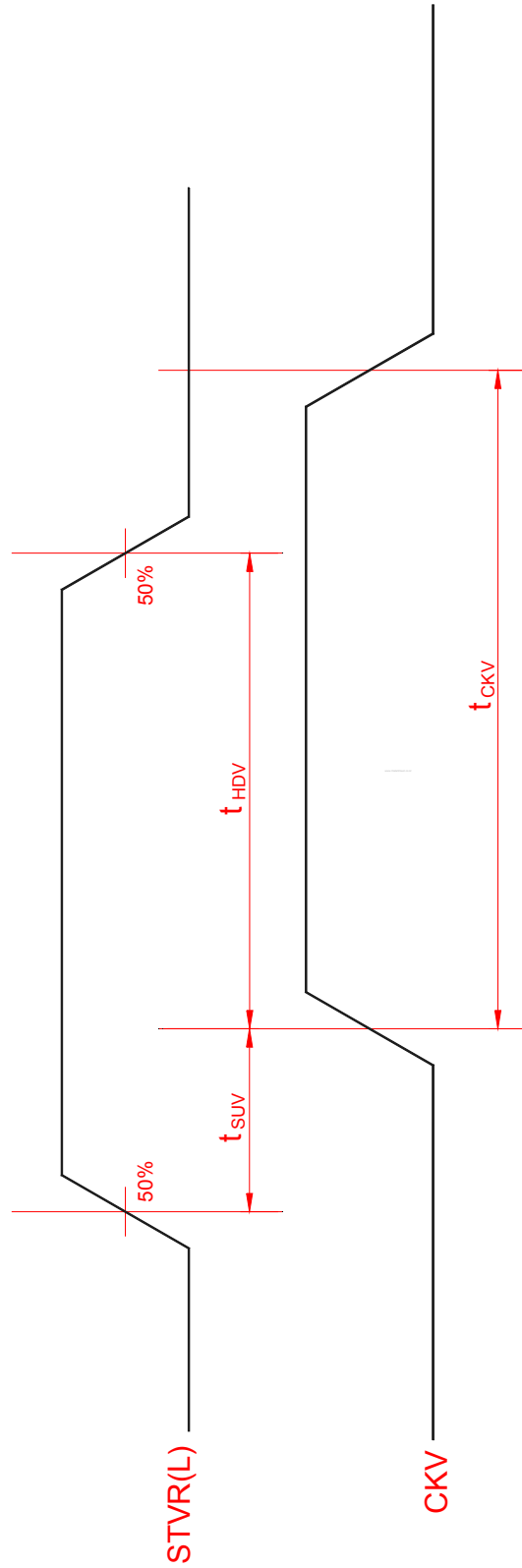

Fig.5 Vertical shift clock timing

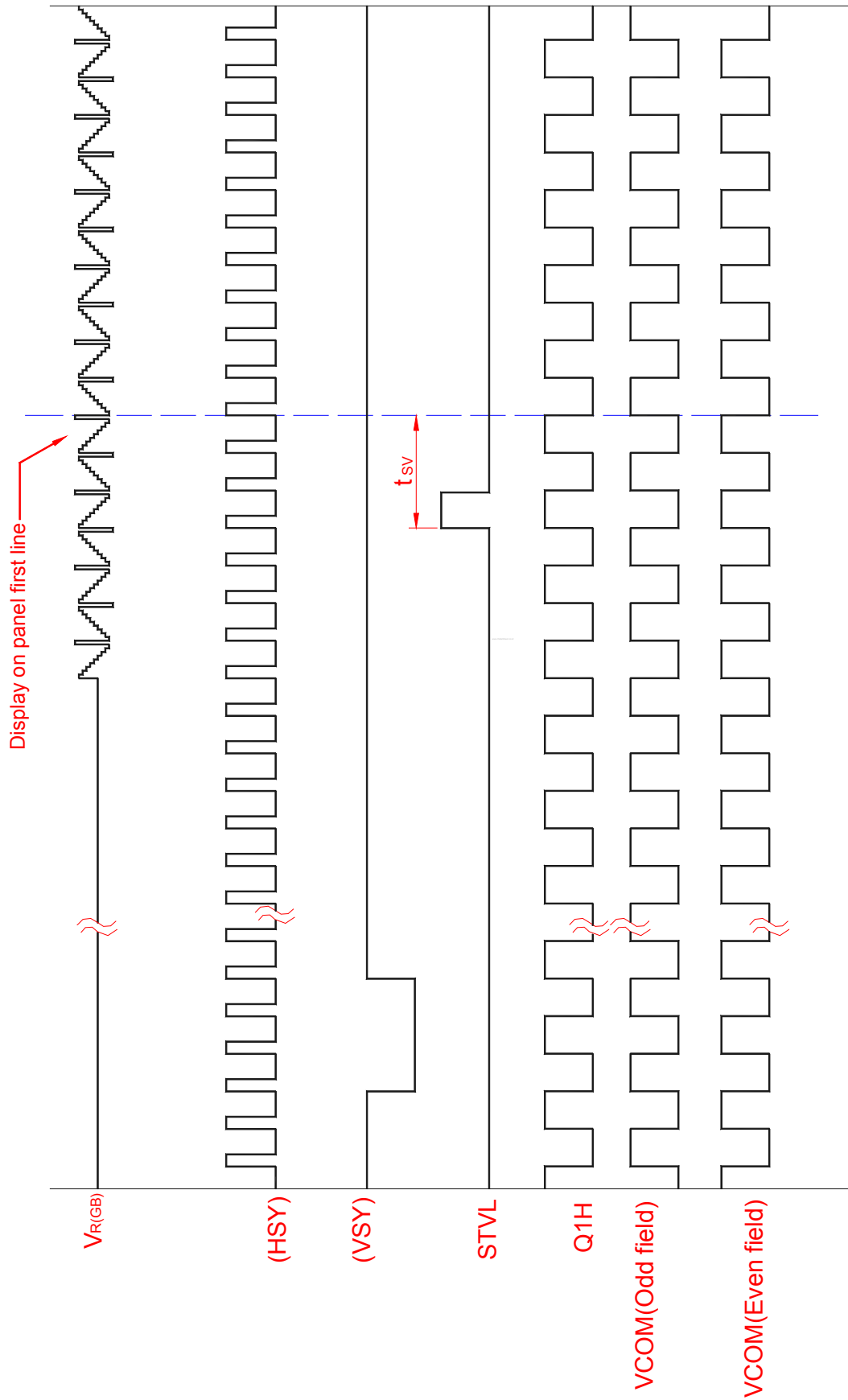

Fig.6-(a) Vertical timing (From up to down)

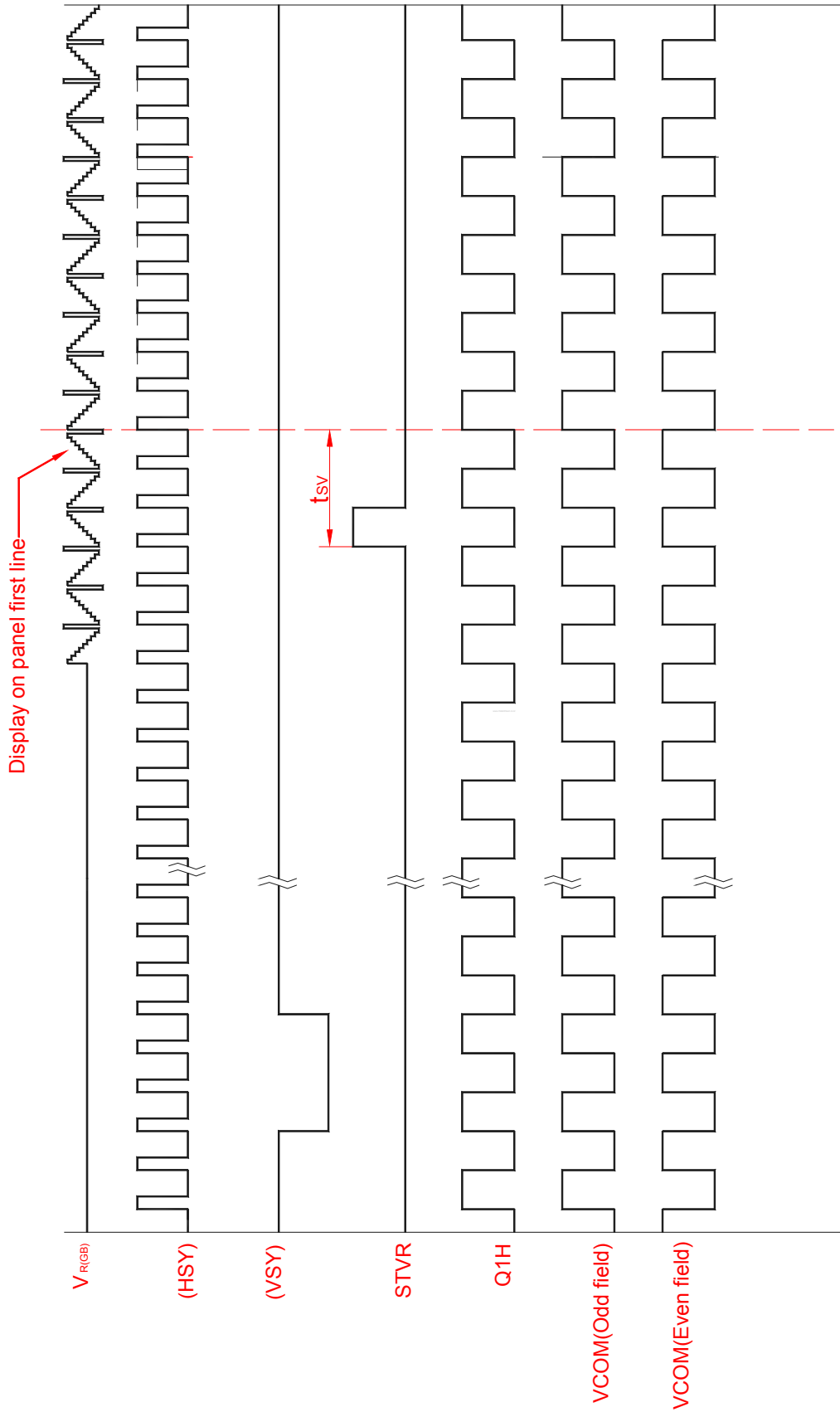

Fig. 6-(b) Vertical timing (From down to up)