



INSTALLATION INSTRUCTIONS

COMP PUMP® SERIES 60FI ELECTRIC FUEL PUMP

PART NO. 4060FI

NOTE: DO NOT RUN THIS PUMP WITHOUT FUEL (EXCEPT FOR BRIEF PERIODS WHILE PRIMING).

PARTS INCLUDED IN THIS KIT

- 4 Nuts, 5/16" – 24
- 4 Washers, Steel 5/16" Flat
- 4 Bolts, Steel 5/16"
- 1 Ring Terminal
- 1 Fuse, 7.5 AMP
- 1 Fuse Holder

GENERAL INFORMATION

The COMP PUMP® 60FI Series Electric Fuel Pump is a high pressure fuel pump designed for fuel injection applications. This fuel pump **must be used with return style (bypass) fuel pressure regulators**. Using this fuel pump with any other kind of fuel pressure regulator (or no regulator) will result in severe fuel pump damage, and will void the product warranty.

At the bottom of the fuel pump is an air bleed system designed to help in priming the fuel pump. The air bleed line is plumbed to the fuel return line. If the fuel pressures you are running are 10 PSI or less, put a 1/8 NPT plug in the air bleed port.

Be sure to install a suitable fuel filter (maximum 100 micron filtration) between the fuel tank and the fuel pump. This prevents debris from becoming wedged in the fuel pump's Gerotor and locking it.

An additional fuel filter (maximum 10 micron, such as the Mallory 160 Series COMP FILTER® Part No. 3160) must be placed between the fuel pump and the injectors. This prevents debris from clogging the injectors.

SPECIFICATIONS

Maximum recommended operating pressure:

55 psi continuous, 65 psi intermittent

Minimum oil pressure switch current rating: 7.5 amps

Fuel pump over current protection: 7.5 amp fuse

Fuel application: Gasoline

This product is covered under one or more of the following U.S. patents: 5,007,806; 4,998,557; 5,111,793; 5,123,436; 5,186,147.

SERVICE PARTS

Brush Kit	3146A
Seal and Repair Kit	3165

MOUNTING PROCEDURE

Step 1

Mount the pump as close as possible to the fuel tank (at or below the level of the fuel tank pickup) in a well ventilated area with minimal exposure to road debris. Avoid exposing the pump and fuel lines to moving parts and hot surfaces, such as the exhaust system.

NOTE: Increasing distance between the pump and tank will decrease pump efficiency.

Step 2

Using the pump mounting bracket as a template, locate mounting holes on a solid member, such as the vehicle chassis. Drill clearance holes for 5/16" bolts. See Figure 1. **NOTE: To ensure against a potential fire hazard from pump flooding, mount the pump in a vertical position with the motor on top.**

Step 3

Connect 5/16" or larger fuel lines as shown in Figure 2. The 1/8" NPT outlet on the bottom of the pump is for an air bleed line to assist pump priming. This air bleed line is not necessary if the regulated pressure of your system is less than 10 psi. **NOTE: Use a thread sealant compound on the fitting threads. Don't use teflon tape because it could get into the Gerotor and lock the pump.**

Step 4

Your system must have a Return Style Fuel Pressure Regulator. For maximum efficiency, mount the pressure regulator as close as possible to the injection system. See instructions packaged with the regulator. The regulator may be mounted before or after the fuel injection.

FIGURE 1



WIRING PROCEDURE

Wiring the pump to an oil pressure switch will provide power only when the ignition switch is on and the engine is running. This will prevent the pump from running if your engine stalls. Use 14 gauge wire or larger and be sure to disconnect the battery ground cable before wiring the pump. Refer to Figure 3 when connecting the pump to an oil pressure switch.

The pump may be wired directly to the ignition switch "ON" terminal and grounded to the frame or battery. Refer to Figure 4 when connecting the pump to the ignition switch "ON" terminal.

MAINTENANCE—PUMP DISASSEMBLY

If your pump fails to produce adequate pressure or volume, it may require cleaning. Follow the steps below to disassemble and clean your Mallory Electric Fuel Pump. Refer to Figure 5 while performing the following steps.

Step 1

Remove the pump from the vehicle and clean pump exterior. Place the pump on its side on a clean work surface. Scribe or draw a line across the pump housing, port plate and fuel chamber so that you can reassemble the pump correctly.

Step 2

Remove the two fuel chamber screws from the bottom of the pump. Remove the fuel chamber and port plate. **NOTE: Do not drop the Gerotor from the pump cavity.**

Step 3

Separate the port plate from the fuel chamber. **NOTE: Do not drop the air bleed check ball and spring from the fuel chamber.** Inspect the flame arrestor screen in the fuel chamber and clean it if necessary.

Step 4

Place your hand beneath the Gerotor and hold the pump in an upright position. The gerotor should slide out of the pump and into your hand. **NOTE: Observe the position of the Gerotor and be careful not to reverse it when you reassemble the pump.** Inspect the gerotor housing and port plate for wear. If the gerotor has worn through the plating, return the pump to Mallory for repair.

Step 5

Inspect the O-ring and gasket. Replace them if necessary. Reinstall the air bleed spring and check ball in the fuel chamber. Place the gasket and port plate on the fuel chamber. Install the fuel chamber assembly on the pump housing. Torque the fuel chamber screws.

NOTE: DO NOT OPERATE THE PUMP WITHOUT FUEL. (Except for brief periods while priming).

IMPORTANT: Turn fuel chamber screws by hand until they contact the chamber. Then torque to 24 inch/pounds

FIGURE 2

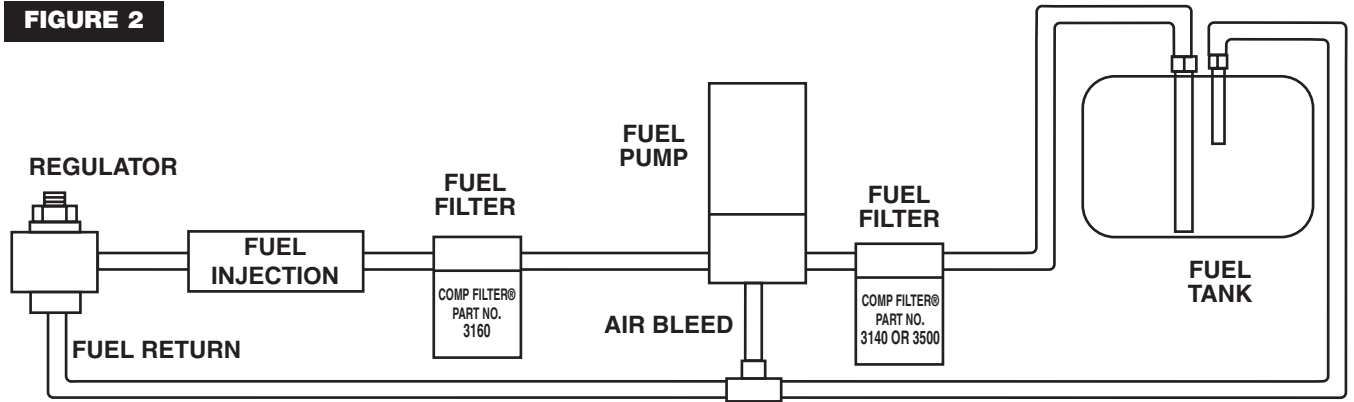

FIGURE 3

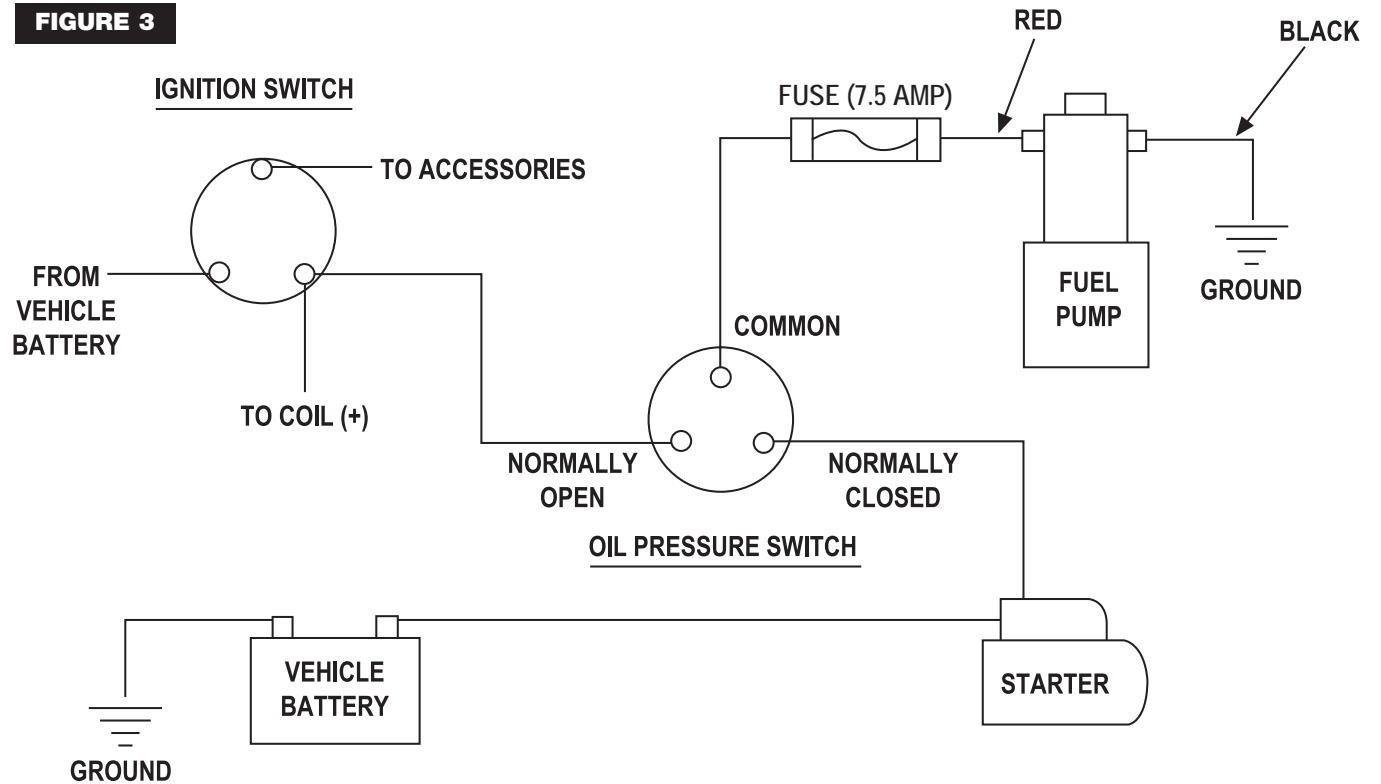
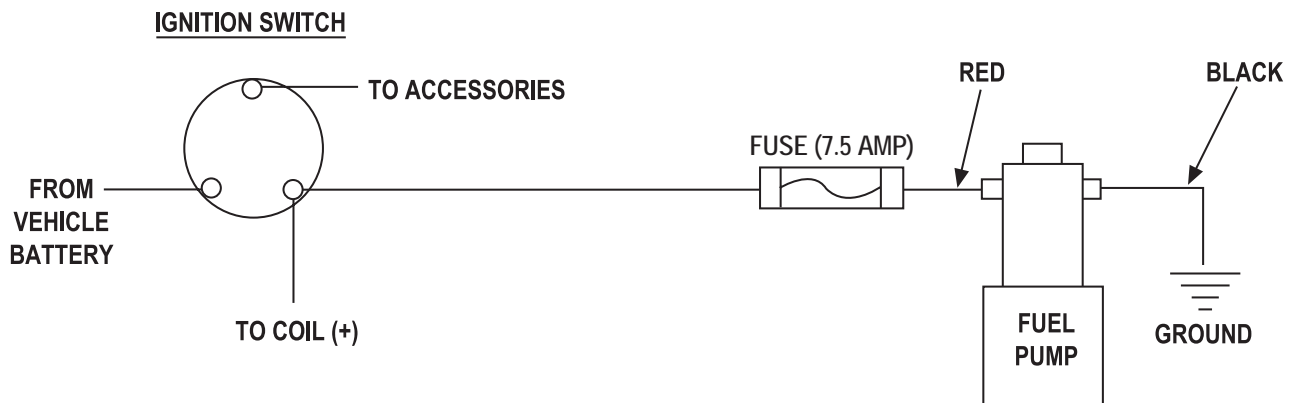

FIGURE 5



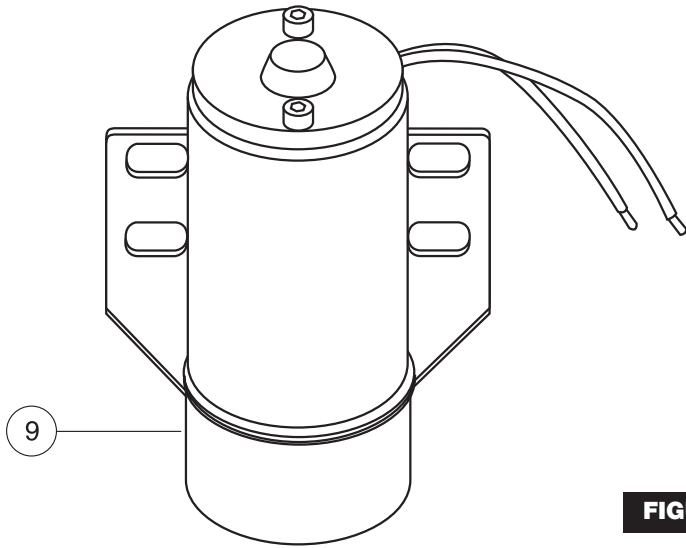

FIGURE 5

1. SCREW, FUEL CHAMBER (2)
2. FUEL CHAMBER
3. SPRING, AIR BLEED
4. BALL, AIR BLEED
5. GASKET, FUEL CHAMBER
6. PORT PLATE
7. GEROTOR
8. O-RING
9. PUMP HOUSING

