

HIGH SPEED LAN MAGNETICS

960016B

- Designed for use with Microlinear 6692/6694/6698 10/100 Mbps PHY transceivers
- Surface mount or through-hole packaging options
- 2000 Vrms isolation
- Complies with IEEE 802.3 standards
- Switching function integrated within magnetics module

ELECTRICALS AT 25°C

Part No.	Turns Ratio		Inductance OCL (μH) Min @8mA bias	Return Loss (dB) Min 1-10MHz	Insertion Loss (dB) Min 1-10MHz	Attenuation (dB) Min 30MHz	Common to Common Mode Rej (dB) Min		Crosstalk (dB) Min 100kHz-100MHz	Schematic	Package Style
	TX	RX					10-30MHz	100MHz			
0556-1060-00	N/A	N/A	N/A	-15	-1.0	-28	N/A	N/A	N/A	A	1
0558-1060-00	2:1	1:1	350	-18	-1.0	-20	-40	-30	-30	B	1
S556-1060-01	N/A	N/A	N/A	-15	-1.0	-28	N/A	N/A	N/A	C	2
S558-1060-01	2:1	1:1	350	-18	-1.0	-20	-40	-30	-30	D	3

SCHEMATICS

A

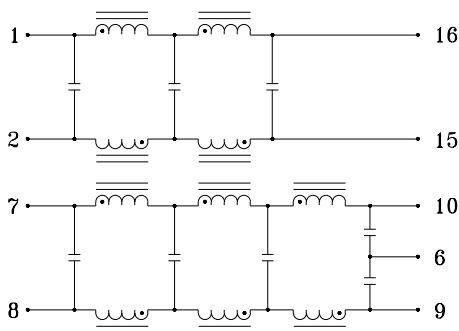

B

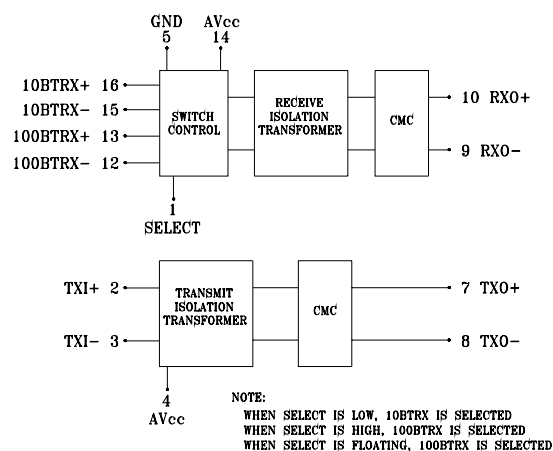

C

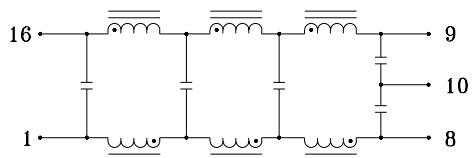

D

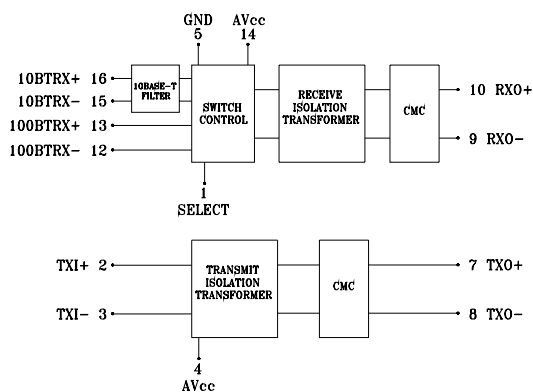

Corporate Office

Bel Fuse Inc.
198 Van Vorst Street, Jersey City, NJ 07302-4496
Tel: 201-432-0463
Fax: 201-432-9542
E-Mail: BelFuse@belfuse.com
Internet: <http://www.belfuse.com>

Far East Office

Bel Fuse Ltd.
8F/8 Luk Hop Street
San Po Kong
Kowloon, Hong Kong
Tel: 852-2328-5515
Fax: 852-2352-3706

European Office

Bel Fuse Europe Ltd.
Preston Technology Management Centre
Marsh Lane, Preston PR1 8UD
Lancashire, U.K.
Tel: 44-1772-556601
Fax: 44-1772-888366



defining a degree of excellence

HIGH SPEED LAN MAGNETICS

960016B

MECHANICALS

1

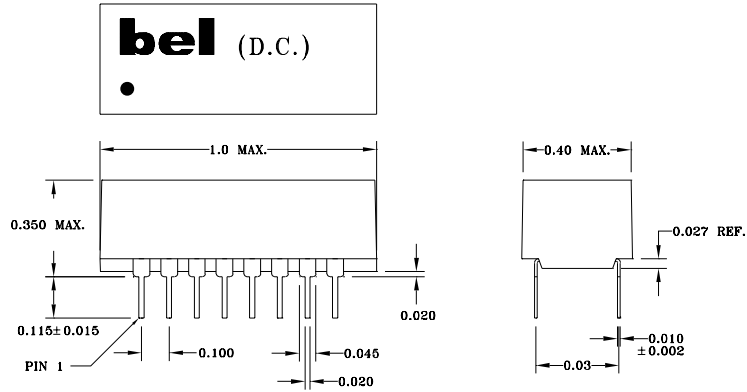

2

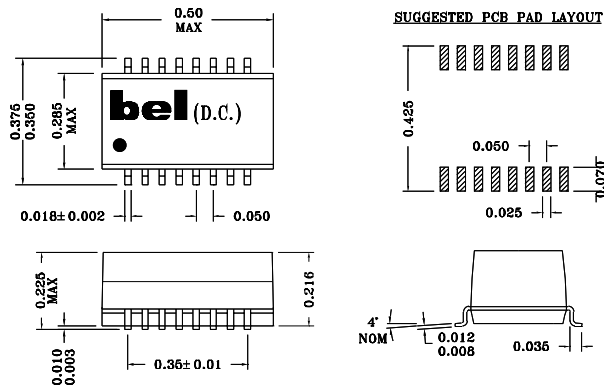

3

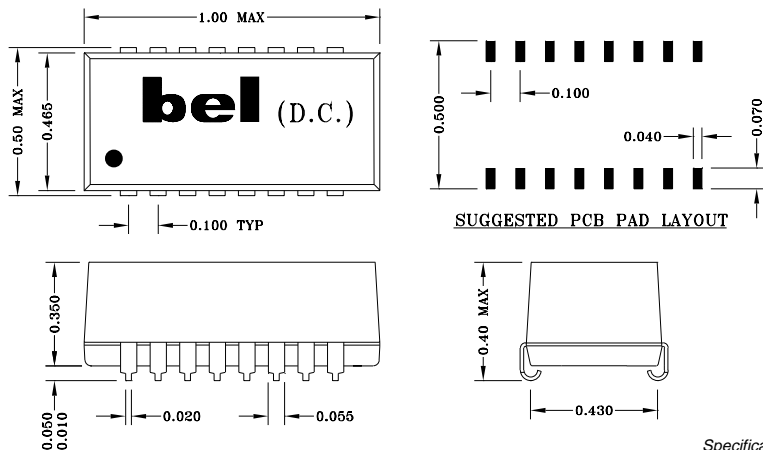

Specifications subject to change without notice.



defining a degree of excellence

HIGHSPEED LAN MAGNETICS

960016B

APPLICATION NOTES

- 0556-1060-00 is for use with 0558-1060-00 and the S556-1060-01 is for use with S558-1060-01.
- These Bel designs are for use with Microlinear 100 Mbps and various 10Base-T PHY devices that may require external filtering. Microlinear provides the following recommendations:

MAC	Microlinear	MII	SYM	Internal 10 BT	Internal 10 BT Filters	7-Wire
DEC21140	6692, 2653	✓	✓			✓
DEC21142	6692	✓		✓		
DEC21143	6698	✓	✓	✓		
AM79C971	6692	✓		✓		✓
I82557	6692, 2653	✓				✓*
MC91C100	6692, 2653	✓				✓
MX98713	6698	✓	✓	✓	✓	
TNETE100	6692	✓		✓	✓	

*I82557 muxes the MII and the 7-wire signals.

- Vcc operating voltage of the Bel magnetics modules is recommended to be 5 volts, +/-5%.
- Two 1k Ω resistors are recommended to provide bias voltage to the Microlinear chipset.
- 0.1 μ F DC blocking capacitors are recommended to provide isolation between the 10 Mbps and 100 Mbps PHY transceivers.

Corporate Office

Bel Fuse Inc.
198 Van Vorst Street, Jersey City, NJ 07302-4496
Tel: 201-432-0463
Fax: 201-432-9542
E-Mail: BelFuse@belfuse.com
Internet: <http://www.belfuse.com>

Far East Office

Bel Fuse Ltd.
8F/8 Luk Hop Street
San Po Kong
Kowloon, Hong Kong
Tel: 852-2328-5515
Fax: 852-2352-3706

European Office

Bel Fuse Europe Ltd.
Preston Technology Management Centre
Marsh Lane, Preston PR1 8UD
Lancashire, U.K.
Tel: 44-1772-556601
Fax: 44-1772-888366