

## 2x5 SFF GE-PON ONU Transceiver

### FTM-9412P-F20F

(IEEE 802.3ah™-2004 1000BASE-PX20-U)

Members of Flexon™ Family



#### Applications

- ◆ Gigabit Ethernet Passive Optical Networks (GE-PON) – ONU side
- ◆ Gigabit Ethernet Point-to-Point Bi-directional Transmission
- ◆ Media Converts for Fiber-In-The-Loop (FITL)

#### Features

- ◆ Single fiber bi-directional data links with symmetric 1.25Gbps upstream and 1.25Gbps downstream
- ◆ 20km transmission application supported
- ◆ Integrated micro-optics WDM filter for dual wavelength Tx/Rx operation at 1310/1490nm
- ◆ Burst mode operation transmitter with 1310nm FP laser
- ◆ Continuous mode operation receiver with 1490nm high sensitivity PIN-TIA and 1550nm optical signal rejection
- ◆ 0 to 70°C operating ambient temperature
- ◆ 2 × 5 SFF package with single mode fiber pigtailed SC/UPC connector
- ◆ Single +3.3V power supply
- ◆ LVPECL compatible data input/output interface
- ◆ LVTTTL transmitter laser burst mode control
- ◆ LVTTTL receiver signal-detected indication
- ◆ Low EMI and excellent ESD protection
- ◆ Class I laser safety standard IEC-60825 compliant

#### Standard

- ◆ Compliant with IEEE Std 802.3ah™ -2004 1000BASE-PX20-U
- ◆ Compliant with FCC 47 CFR Part 15, Class B
- ◆ Compliant with FDA 21 CFR 1040.10 and 1040.11, Class I

#### Description

FTM-9412P-F20F is Optical Network Unit (ONU) for IEEE802.3ah™-2004 1000BASE-PX20 application.

The transceiver is the high performance module for 1.25Gbps data link in single fiber by using 1310nm burst mode transmitter and 1490nm continuous mode receiver with 1550nm optical signal rejection.

The transmitter section uses a multiple quantum well 1310nm FP laser and is class I laser complaint product according to International Safety Standard IEC-60825, supporting burst-mode operation. The receiver section uses an integrated 1490nm PIN and preamplifier mounted in an optical header and limiting post-amplifier IC.

## Regulatory Compliance

The transceivers have been tested according to American and European product safety and electromagnetic compatibility regulations (See Table 1). For further information regarding regulatory certification, please refer to Flexon™ regulatory specification and safety guidelines, or contact with Fiberxon, Inc. America sales office listed at the end of documentation.

**Table 1 - Regulatory Compliance**

Feature	Standard	Performance
Electrostatic Discharge (ESD) to the Electrical Pins	MIL-STD-883E Method 3015.7	Class 1(>500 V)
Electromagnetic Interference (EMI)	FCC Part 15 Class B EN55022 Class B (CISPR 22B) VCCI Class B	Compliant with standards
Immunity	IEC 61000-4-3	Compliant with standards
Laser Eye Safety	FDA 21CFR 1040.10 and 1040.11 EN (IEC) 60825-1 EN (IEC) 60825-2	Compliant with Class I Laser Product
Component Recognition	UL 60950 and EN (IEC) 60950	Compliant with standards

## Absolute Maximum Ratings

Absolute Maximum Ratings are those values, beyond which, some damages may occur to the devices. Exposure to conditions above the Absolute Maximum Ratings listed in Table 2 may negatively impact the reliability of the products.

**Table 2 - Absolute Maximum Ratings**

Parameter	Symbol	Min.	Max.	Unit	Note
Storage Ambient Temperature	T <sub>STG</sub>	-40	85	°C	1
Operating Ambient Temperature	T <sub>OPR</sub>	0	70	°C	
Power Supply Voltage	V <sub>CC</sub>	0	4	V	
Input Voltage		GND	V <sub>cc</sub>	V	
Receiver Damaged Threshold		+7		dBm	
Soldering Temperature			400	°C	2
Bending Radius		30		mm	
Pigtail Fiber Contact Temperature			85	°C	

Note 1: With airflow 1m/sec

Note 2: Only for soldering by iron and 10 seconds on leads only

## Recommended Operating Conditions

**Table 3 - Recommended Operating Conditions**

Parameter	Symbol	Min.	Typ.	Max.	Unit	Notes
Power Supply Voltage	$V_{CC}$	3.13	3.3	3.47	V	$3.3 \pm 5\%$
Operating Ambient Temperature	$T_{OPR}$	0		70	°C	1
Operating Humidity	$H_{OPR}$	5		95	%	
Data Rate			1.25		Gbit/s	
Data Rate Drift		-100		+100	PPM	

Note 1: When ambient temperature is above 60°C, airflow at rate higher than 1m/sec is required

## Optical and Electrical Characteristics

**Table 4 - Transmitter Optical and Electrical Characteristics (0°C <  $T_{OPR}$  < 70°C and 3.13V <  $V_{CC}$  < 3.47V)**

Parameter	Symbol	Min.	Typ.	Max.	Unit	Notes
Output Optical Center Wavelength	$\lambda_C$	1304		1320	nm	1
Output Optical Spectral Width (RMS)	$\Delta\lambda$			2.5	nm	
Average Launch Power (BOL)	$P_{OUT}$	1		+4	dBm	2
Average Launch Power (EOL)		0		+4	dBm	
Average Launch Power-OFF Transmitter	$P_{OFF}$			-45	dBm	
Extinction Ratio	ER	9			dB	3
Burst Turn On Time	$T_{BURST\_ON}$			64	ns	4
Burst Turn Off Time	$T_{BURST\_OFF}$			64	ns	
Burst Enable Duration	$T_{EN\_DUR}$	600			ns	
Burst Disable Duration	$T_{DIS\_DUR}$	100			ns	
Rise/Fall Time (20%-80%)	$T_R/T_F$			260	ps	3,5
Total Jitter	$J_{TOTAL\_T}$			0.35	UI	
Relative Intensity Noise	$RIN_{15}OMA$			-115	dB/Hz	
Optical Return Loss Tolerance				15	dB	
Transmitter Reflectance				-10	dB	
Transmitter and Dispersion Penalty	TDP			1.8	dB	6
Transmitter Eye Diagram	Compliant With IEEE Std 802.3ah™-2004					3,7
Data Input Differential Swing	$V_{IN}$	200		1600	mV	8
Input Differential Impedance	$Z_{IN}$	90	100	110	$\Omega$	
Power Supply Current	$I_{CC\_TX}$			200	mA	
Transmitter Burst Control Voltage - Low	$V_{BURST\_L}$	0		0.8	V	9
Transmitter Burst Control Voltage - High	$V_{BURST\_H}$	2.0		V <sub>CC</sub>	V	

Note 1: Guaranteed under 25°C ambient temperature

Note 2: Launched into 9/125um SMF.

Note 3: Measured with PRBS 2<sup>7</sup>-1 test pattern @1.25Gbps.

Note 4: Refer to [Timing Parameter Definition in Burst Mode Sequence](#).

Note 5: Measured with the Bessel-Thompson filter OFF.

Note 6: Maximum sensitivity penalty due to transmitter and dispersion effect through 20km of SMF optical

fiber at 25°C ambient temperature

Note 7: Transmitter eye mask definition is {0.22UI, 0.375UI, 0.20UI, 0.20UI, 0.30UI}.

Note 8: Compatible with LVPECL/CML input, AC coupled internally. (See [Recommended Interface Circuit](#))

Note 9: TX\_BRST (See [Pin Function Definitions](#))

**Table 5 - Receiver Optical and Electrical Characteristics (0°C <T<sub>OPR</sub><70°C and 3.13V<V<sub>CC</sub><3.47V)**

Parameter	Symbol	Min.	Typ.	Max.	Unit	Notes
Operating Wavelength		1480		1500	nm	
Sensitivity	P <sub>SEN</sub>			-27.5	dBm	1
Saturation Power	P <sub>SAT</sub>	-3			dBm	
Signal Detect Assert Level	P <sub>SDA</sub>			-28	dBm	2
Signal Detect Deassert Level	P <sub>SDD</sub>	-39			dBm	3
Signal Detect Hysteresis	P <sub>SDA</sub> -P <sub>SDD</sub>	0.5		6	dB	
Power Supply Current	I <sub>CC_RX</sub>			120	mA	4
Receiver Reflectance				-12	dB	
Data Output Voltage - Low	V <sub>OL</sub> -V <sub>CC</sub>	-2.0		-1.58	V	5
Data Output Voltage - High	V <sub>OH</sub> -V <sub>CC</sub>	-1.1		-0.74	V	
Signal Detect Voltage - Low	V <sub>SD, L</sub>	0		0.8	V	6
Signal Detect Voltage - High	V <sub>SD, H</sub>	2.0		V <sub>CC</sub>	V	
Signal Detect Assert Time	T <sub>ASS</sub>			100	μs	
Signal Detect Deassert Time	T <sub>DAS</sub>			100	μs	
WDM Filter Isolation		38			dB	7
		35			dB	8

Note 1: Measured with a PRBS 2<sup>7</sup>-1 test pattern @1.25Gbps and ER=9dB, BER ≤1×10<sup>-12</sup>.

Note 2: An increase in optical power above the specified level will cause the Signal Detect output to switch from a low state to a high state.

Note 3: A decrease in optical power below the specified level will cause the Signal Detect output to switch from a high state to a low state.

Note 4: Supply current excluding receiver output load.

Note 5: LVPECL output, AC coupled internally. (See [Recommended Interface Circuit](#))

Note 6: SD (See [Pin Function Definitions](#))

Note 7: Tested at 1550nm

Note 8: Tested at 1650nm

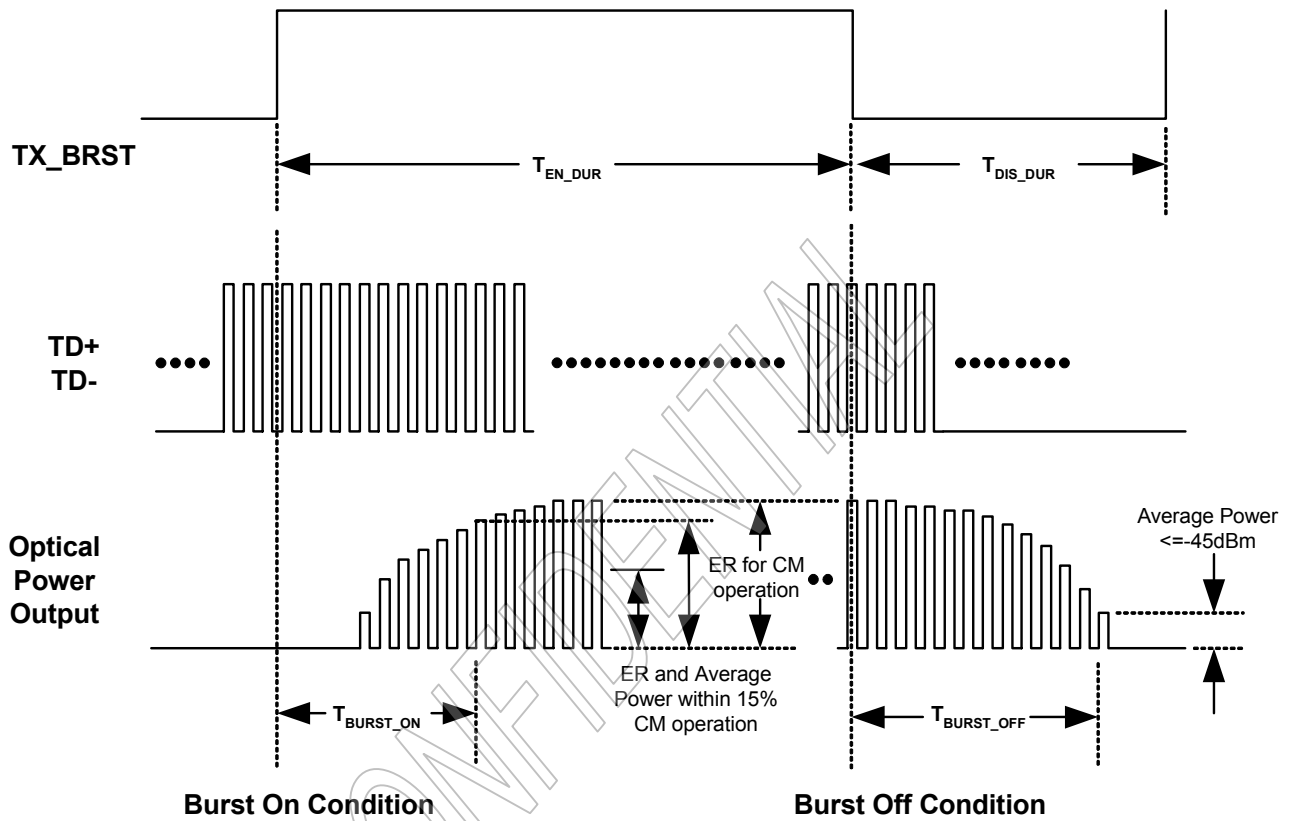

Figure 1 Timing Parameter Definition in Burst Mode Sequence

### Recommended Interface Circuit

Figure 2 shows the recommended interface schemes.

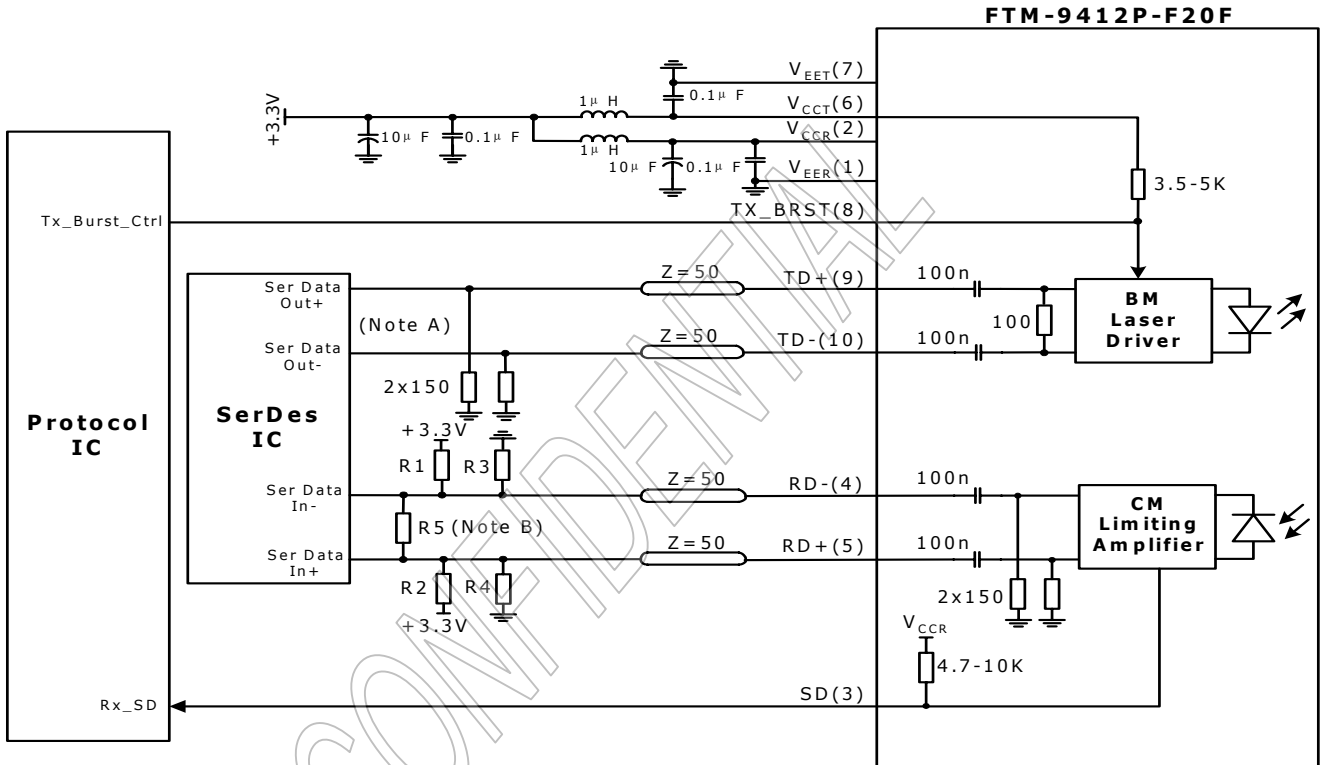

Figure 2 Recommended Interface Circuit

Note A: Open emitter output internally.

Note B: LVPECL output, AC coupled internally.

Input stage in SerDes IC is assumed with high impedance and internal bias to V<sub>CC</sub>-1.3V

R1=R2=R3=R4=N.C, R5=100Ω

Input stage in SerDes IC is assumed without internal bias to V<sub>CC</sub>-1.3V

R1=R2=82Ω, R3=R4=130Ω, R5=N.C

### Pin Definitions

2x5 SFF platform in Figure 3 below shows the pin information of electrical interface and mounting studs. Functions are described in Table 6 with some accompanying notes.

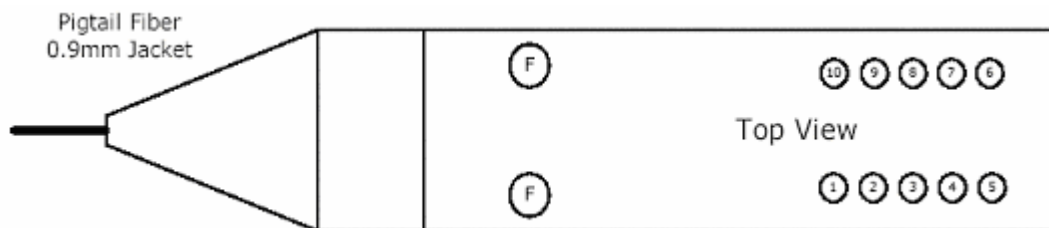

Figure 3 2x5 SFF Platform

**Table 6 - Pin Function Definitions**

Pin No.	Name	Description	Notes
1	V <sub>EER</sub>	Receiver Signal Ground	
2	V <sub>CCR</sub>	Receiver Power Supply	
3	SD	Receiver Signal Detect	1
4	RD-	Inverted Receiver Data Output	2
5	RD+	Non-inverted Receiver Data Output	2
6	V <sub>CCT</sub>	Transmitter Power Supply	
7	V <sub>EET</sub>	Transmitter Signal Ground	
8	TX_BRST	Transmitter Burst Output Control	3
9	TD+	Transmitter Non-inverted Data Input	4
10	TD-	Transmitter Inverted Data Input	4
F	MS	Mounting Studs	5

Note 1: TTL logic output, with internal 4.7-10K $\Omega$  pull-up resistor.

Optical Signal Detected: High; Optical Signal Loss: Low

Note 2: LVPECL logic output, internally AC-coupled. (See [Recommended Interface Circuit](#))

Note 3: A positive pulse controls the burst mode optical power output with an internal 3.5~5K $\Omega$  pull-up resistor. (See [Timing Parameter Definition in Burst Mode Sequence](#))

Note 4: LVPECL logic input, internally terminated and AC-coupled. (See [Recommended Interface Circuit](#))

Note 5: The mounting studs are provided for transceiver mechanical attachment to circuit board. They may also provide an optional connection of the transceiver to the equipment chassis ground. The holes in the circuit board must be tied to chassis ground. It is not recommended that the mounting studs be connected to signal ground.

## Mechanical Design Diagram

The form factor is 2×5 SFF with pigtail fiber. The pigtail fiber has a length of 613±30mm and 30mm minimum bending radius. The fiber connector type is SC/UPC. The mechanical design diagram is shown in Figure 4. (Dimension in mm)

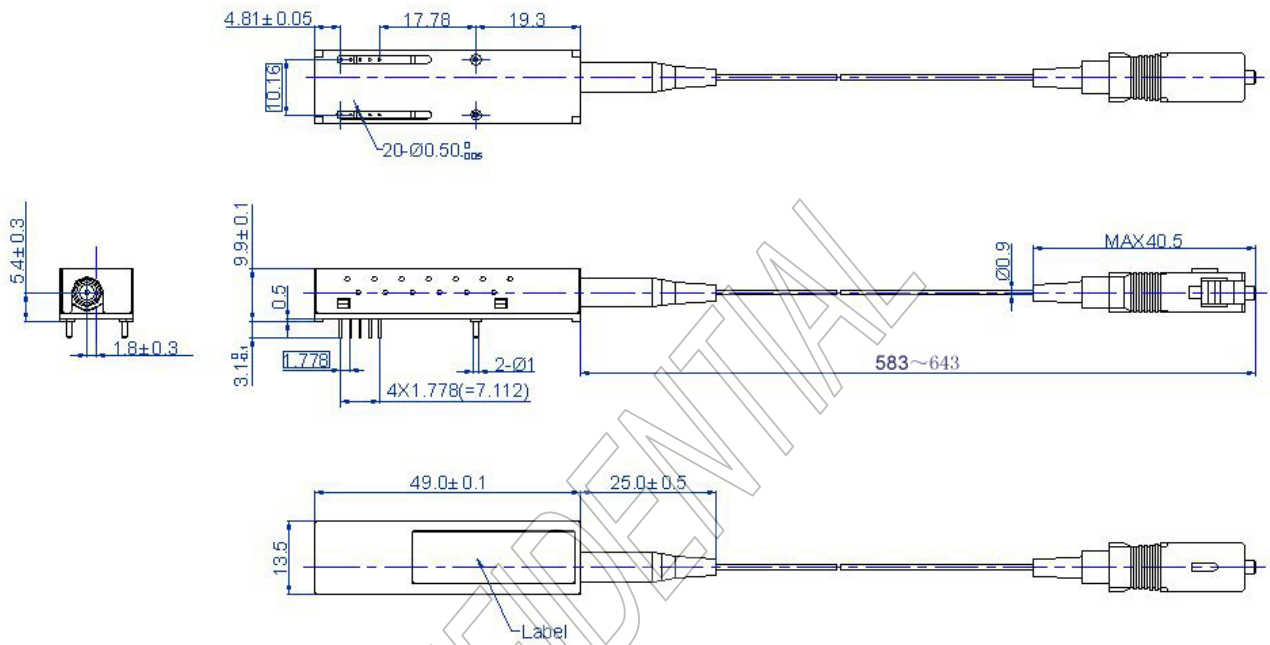

Figure 4 Mechanical Design Diagram

Table 7 - Pigtail Fibre Characteristics

Parameter	Min.	Typical	Max.	Unit
Mode Field Diameter		9		μ m
Gladding Diameter		125		μ m
Jacket Diameter		0.9		mm
Bending Radius of Pigtail Fibre	30			mm
Tension Force on Pigtail Fibre			1	Kg
Pigtail Fibre Length	583	613	643	mm
Optical Return Loss (UPC type)-1310nm	50			dB





## Revision History

Version	Subject	Release Date
Preliminary 1a	Initial datasheet	2005-1-27

**© Copyright Fiberxon Inc. 2004**

All Rights Reserved.

All information contained in this document is subject to change without notice. The products described in this document are NOT intended for use in implantation or other life support applications where malfunction may result in injury or death to persons.

The information contained in this document does not affect or change Fiberxon’s product specifications or warranties. Nothing in this document shall operate as an express or implied license or indemnity under the intellectual property rights of Fiberxon or third parties. All information contained in this document was obtained in specific environments, and is presented as an illustration. The results obtained in other operating environment may vary.

THE INFORMATION CONTAINED IN THIS DOCUMENT IS PROVIDED ON AN "AS IS" BASIS. In no event will Fiberxon be liable for damages arising directly from any use of the information contained in this document.

Contact

U.S.A. Headquarter:

5201 Great America Parkway, Suite 350

Santa Clara, CA 95054

U. S. A.

Tel: 408-562-6288

Fax: 408-562-6289

Or visit our website: <http://www.fiberxon.com/>