MR27V6452D

Preliminary

4,194,304-Word x 16-Bit or 8,388,608-Word x 8-Bit

8-Word x 16-Bit or 16-Word x 8-Bit Page Mode One Time PROM

DESCRIPTION

The MR27V6452D is a 64Mbit electrically Programmable Read-Only Memory with page mode. Its configuration can be electrically switched between 4,194,304 word x 16bit and 8,388,608 word x 8 bit. The MR27V6452D operates on a single +3.3V power supply and is TTL compatible. The MR27V6452D provides Page mode which can greatly reduce the read access time. Since the MR27V6452D operates asynchronously, external clocks are not required, making this device easy-to-use. The MR27V6452D is suitable as large-capacity fixed memory for microcomputers and data terminals. It is manufactured using a CMOS double silicon gate technology and is offered in 44-pin SOP or 48-pin TSOP packages.

FEATURES

- 4,194,304 word x 16bit / 8,388,608 word x 8bit electrically switchable configuration
- Single +3.3V power supply
- Access time 120ns
 - Page mode access time 40ns
- Input / Output TTL compatible
- Three-state output
- Packages
 - 44-pin plastic SOP (SOP44-P-600-1.27-K)
 - 48-pin plastic TSOP (TSOP II 48-P-550-0.80-K)

PIN CONFIGURATION (TOP VIEW)

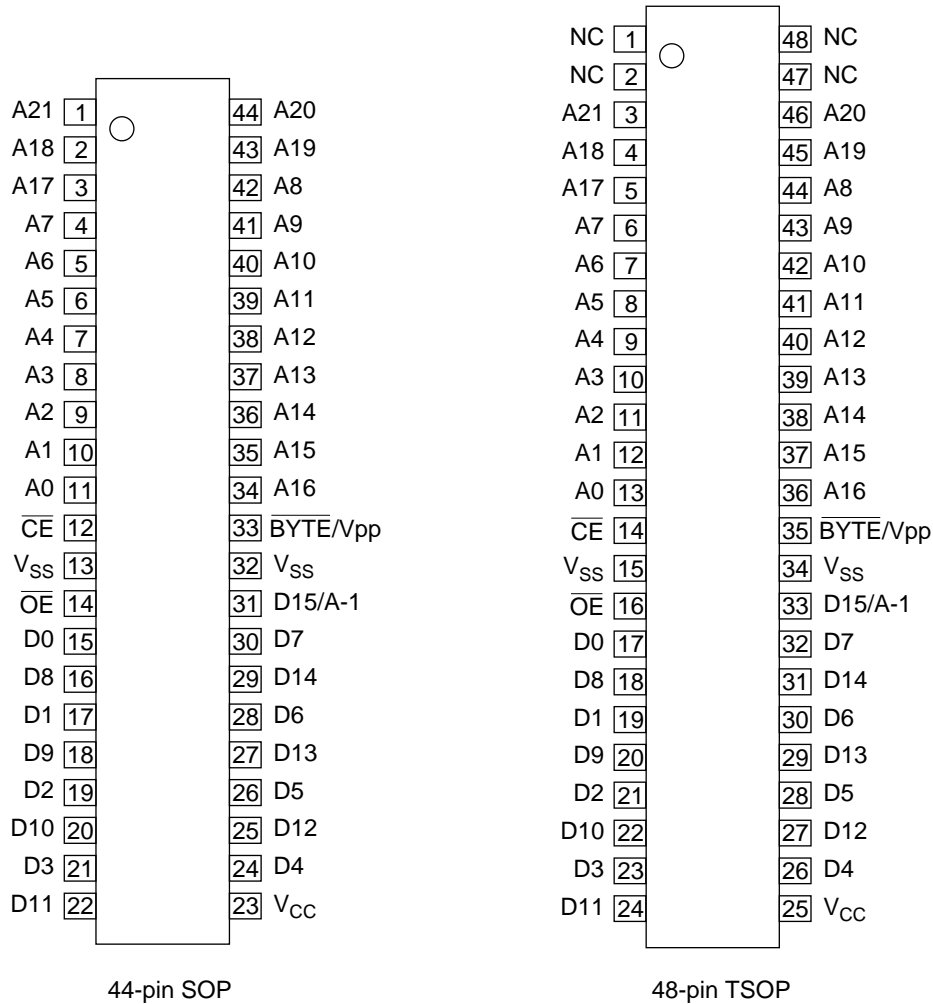

PIN NAMES	FUNCTIONS
D15/A-1	Data output / Address input
A0 - A21	Address input
D0 - D14	Data output
\overline{CE}	Chip enable
\overline{OE}	Output enable
V _{CC}	Power supply voltage
V _{SS}	GND
BYTE/V _{PP}	Mode switch / Program power supply voltage
NC	Non connection

BLOCK DIAGRAM

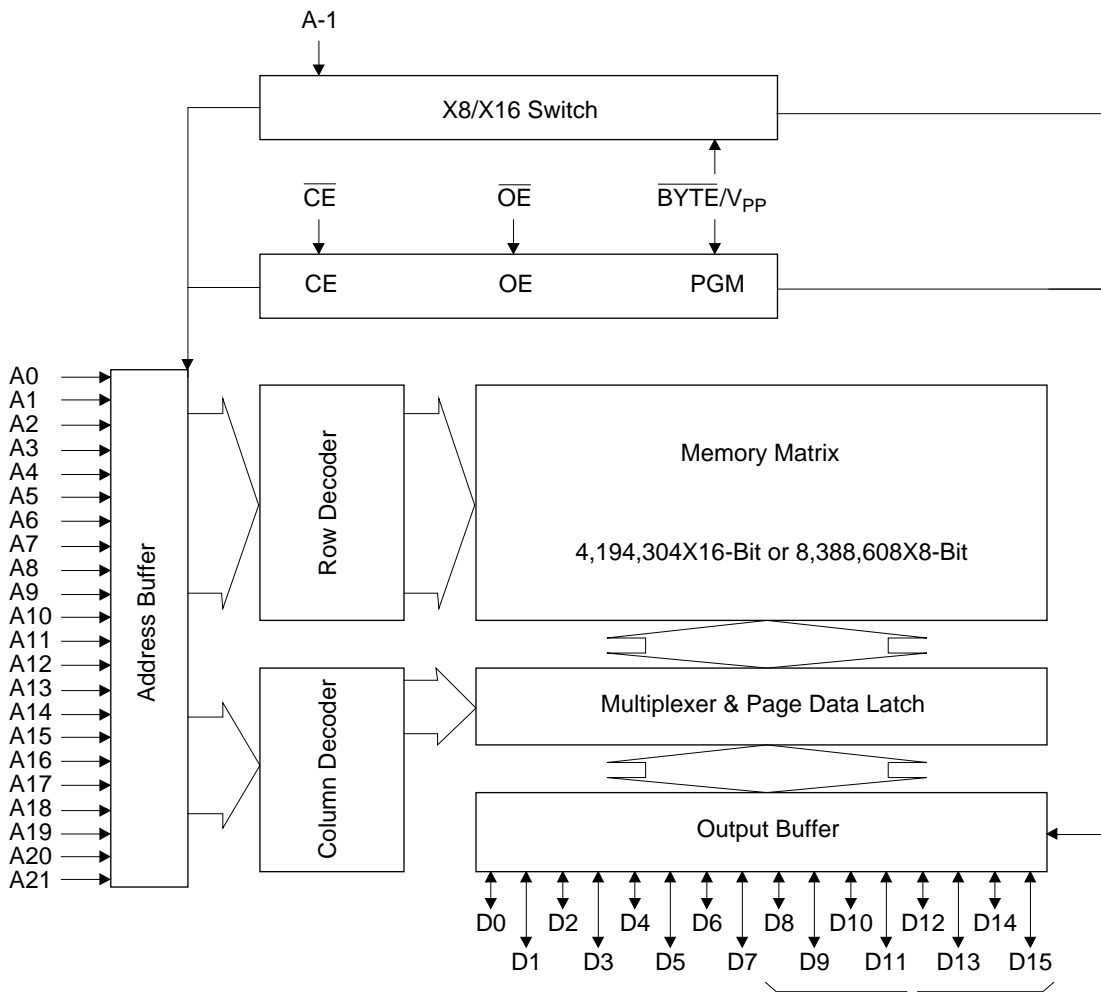

In 8-bit output mode, these pins are three-stated and pin D15 functions as the A-1 address pin.

FUNCTION TABLE

MODE	\overline{CE}	\overline{OE}	BYTE/ V_{PP}	V_{CC}	D0 - D7	D8 - D14	D15/A-1
READ (16-Bit)	L	L	H	3.0V to 3.6V	D_{OUT}		
READ (8-Bit)	L	L	L		D_{OUT}	Hi-Z	L/H
OUTPUT DISABLE	L	H	H		Hi-Z		
			L		*		
STAND-BY	H	*	H	Hi-Z			
			L	*			
PROGRAM	L	H	9.75V	4.0V	D_{IN}		
PROGRAM INHIBIT	H	H			Hi-Z		
PROGRAM VERIFY	H	L			D_{OUT}		

* : Don't Care

ABSOLUTE MAXIMUM RATINGS

Parameter	Symbol	Condition	Value	Unit
Operating temperature under bias	T_{opr}	-	0 to 70	°C
Storage temperature	T_{stg}	-	-55 to 125	°C
Input voltage	V_I	relative to V_{SS}	-0.5 to $V_{CC} + 0.5$	V
Output voltage	V_O		-0.5 to $V_{CC} + 0.5$	V
Power supply voltage	V_{CC}		-0.5 to 5	V
Program power supply voltage	V_{PP}		-0.5 to 11.5	V
Power dissipation per package	P_D	-	1.0	W

RECOMMENDED OPERATING CONDITIONS FOR READ

(Ta=0 to 70°C)

Parameter	Symbol	Condition	Min.	Typ.	Max.	Unit
V_{CC} power supply voltage	V_{CC}	$V_{CC}=3.0V-3.6V$	3.0	-	3.6	V
V_{PP} power supply voltage	V_{PP}		-0.5	-	$V_{CC}+0.5$	V
Input "H" level	V_{IH}		2.2	-	$V_{CC}+0.5$	V
Input "L" level	V_{IL}		-0.5	-	0.8	V

Voltage is relative to V_{SS}

ELECTRICAL CHARACTERISTICS (Read operation)**DC Characteristics** $(V_{CC}=3.3V\pm 0.3V, T_a=0 \text{ to } 70^\circ\text{C})$

Parameter	Symbol	Condition	Min.	Typ.	Max.	Unit
Input leakage current	I_{LI}	$V_I=0 \text{ to } V_{CC}$	-	-	10	μA
Output leakage current	I_{LO}	$V_O=0 \text{ to } V_{CC}$	-	-	10	μA
V_{CC} power supply current (Standby)	I_{CS1}	$\overline{CE}=V_{CC}$	-	-	10	μA
	I_{CS2}	$\overline{CE}=V_{IH}$	-	-	1	mA
V_{CC} power supply current (Read)	I_{CCA}	$\overline{CE}=V_{IL}, \overline{OE}=V_{IH}$ $t_c=120\text{ns}$	-	-	100	mA
V_{PP} power supply current	I_{PP}	$V_{PP}=V_{CC}$	-	-	10	μA
Input "H" level	V_{IH}	-	2.0	-	$V_{CC}+0.5$	V
Input "L" level	V_{IL}	-	-0.5	-	0.8	V
Output "H" level	V_{OH}	$I_{OH}=-200\mu\text{A}$	$V_{CC}-0.4$	-	-	V
Output "L" level	V_{OL}	$I_{OL}=1\text{mA}$	-	-	0.4	V

Voltage is relative to V_{SS} **AC Characteristics** $(V_{CC}=3.3V\pm 0.3V, T_a=0 \text{ to } 70^\circ\text{C})$

Parameter	Symbol	Condition	Min.	Max.	Unit
Address access cycle time	T_C	-	120	-	ns
Address access time	T_{ACC}	$\overline{CE}=\overline{OE}=V_{IL}$	-	120	ns
Page set up time	T_{PSET}	NOTE(1)	120	-	ns
Page access cycle time	T_{PC}	-	40	-	ns
Page access time	T_{PAC}	-	-	40	ns
\overline{CE} access time	T_{CE}	$\overline{OE}=V_{IL}$	-	120	ns
\overline{OE} access time	T_{OE}	$\overline{CE}=V_{IL}$	-	40	ns
Output disable time	T_{CHZ}	$\overline{OE}=V_{IL}$	0	30	ns
	T_{OHZ}	$\overline{CE}=V_{IL}$	0	25	ns
Output hold time	T_{OH}	$\overline{CE}=\overline{OE}=V_{IL}$	0	-	ns

NOTE(1) T_{PSET} is defined as the end of either \overline{CE} trailing edge or address transition in random access term until the first page address transition.

Measurement conditions

Input signal level	-----	0V/3V
Input timing reference level	-----	0.8V/2.0V
Output load	-----	100pF
Output timing reference level	-----	0.8V/2.0V

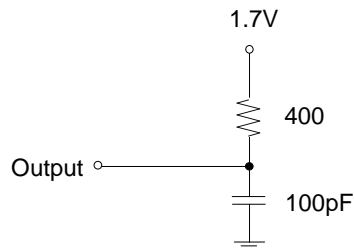

TIMING CHART

NORMAL MODE READ CYCLE

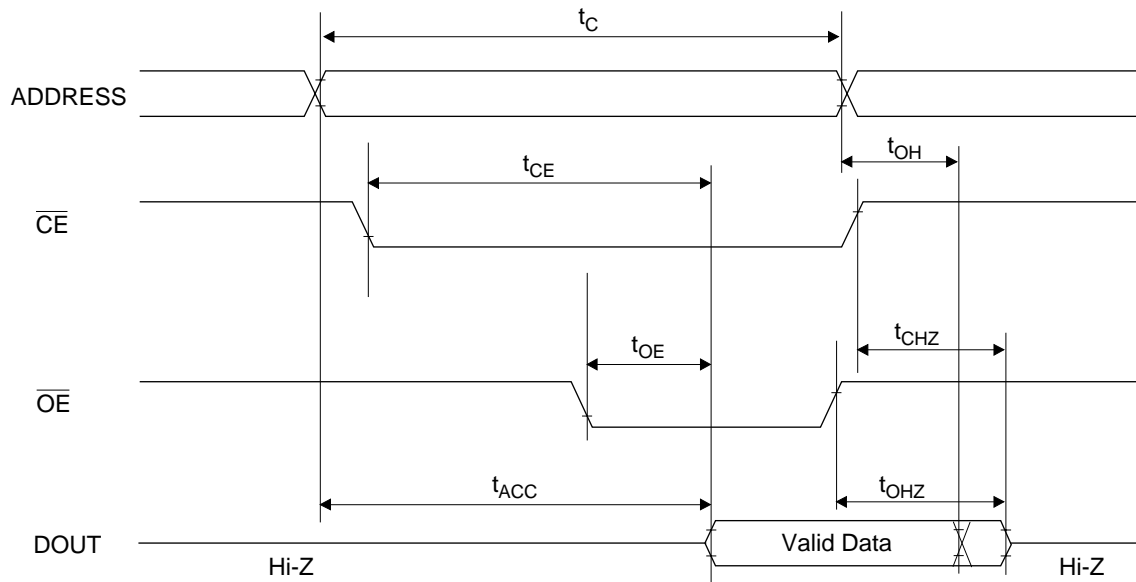

PAGE MODE READ CYCLE

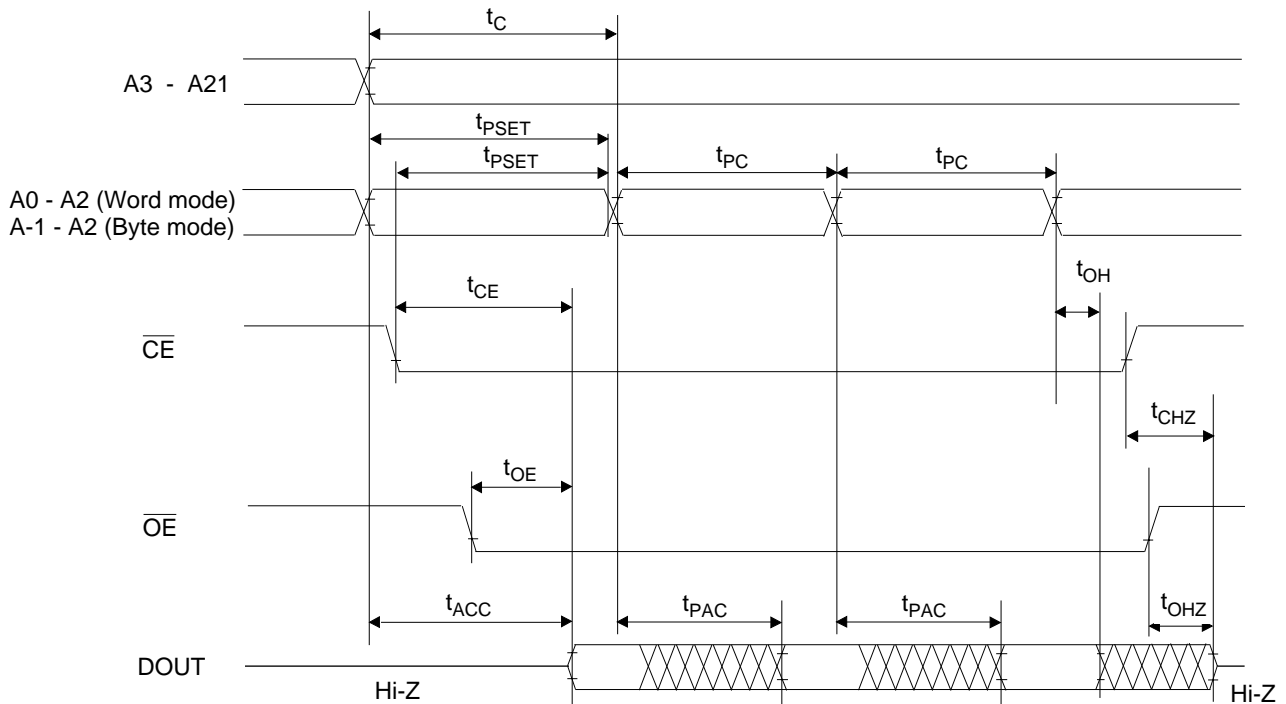

ELECTRICAL CHARACTERISTICS (Programming operation)**DC Characteristics**

(Ta=25°C±5°C)

Parameter	Symbol	Condition	Min.	Typ.	Max.	Unit
Input leakage current	I _{LI}	V _I =V _{CC} +0.5V	-	-	10	μA
V _{PP} power supply current (Program)	I _{PP2}	$\overline{CE}=V_{IL}$	-	-	50	mA
V _{CC} power supply current	I _{CC}	-	-	-	80	mA
Input "H" level	V _{IH}	-	3.0	-	V _{CC} +0.5	V
Input "L" level	V _{IL}	-	-0.5	-	0.8	V
Output "H" level	V _{OH}	I _{OH} =-400μA	2.4	-	-	V
Output "L" level	V _{OL}	I _{OL} =2.1mA	-	-	0.45	V
Program voltage	V _{PP}	-	9.5	9.75	10.0	V
V _{CC} power supply voltage	V _{CC}	-	3.9	4.0	4.1	V

Voltage is relative to V_{SS}**AC Characteristics**(V_{CC}=4.0V±0.1V, V_{pp}=9.75V±0.25V, Ta=25°C±5°C)

Parameter	Symbol	Condition	Min.	Typ.	Max.	Unit
Address set-up time	T _{AS}	-	2	-	-	μs
\overline{OE} set-up time	T _{OES}	-	2	-	-	μs
Data set-up time	T _{DS}	-	2	-	-	μs
Address hold time	T _{AH}	-	0	-	-	μs
Data hold time	T _{DH}	-	2	-	-	μs
Output float delay from \overline{OE}	T _{DFP}	-	0	-	130	ns
V _{PP} voltage set-up time	T _{VS}	-	2	-	-	μs
Program pulse width	T _{PW}	-	9	10	11	μs
Data valid from \overline{OE}	T _{OE}	-	-	-	150	ns

Pin Check Function

Pin Check Function is to check contact between each device-pin and each socket-lead with EPROM programmer.

Setting up address as the following condition call the preprogrammed codes on device outputs.

(V_{CC}=3.3V±0.3V, $\overline{CE}=V_{IL}$, $\overline{BYTE}/V_{pp}=V_{IH}$, Ta=25°C±5°C)

A0	A1	A2	A3	A4	A5	A6	A7	A8	A9	A10	A11	A12	A13	A14	A15	A16	A17	A18	A19	A20	A21	DATA
0	1	0	1	0	1	0	1	0	VH*	0	1	0	1	0	1	0	0	1	1	0	0	FF00
1	0	1	0	1	0	1	0	1	VH*	1	0	1	0	1	0	1	1	0	0	1	1	00FF

*: VH=8V

Programming Waveform

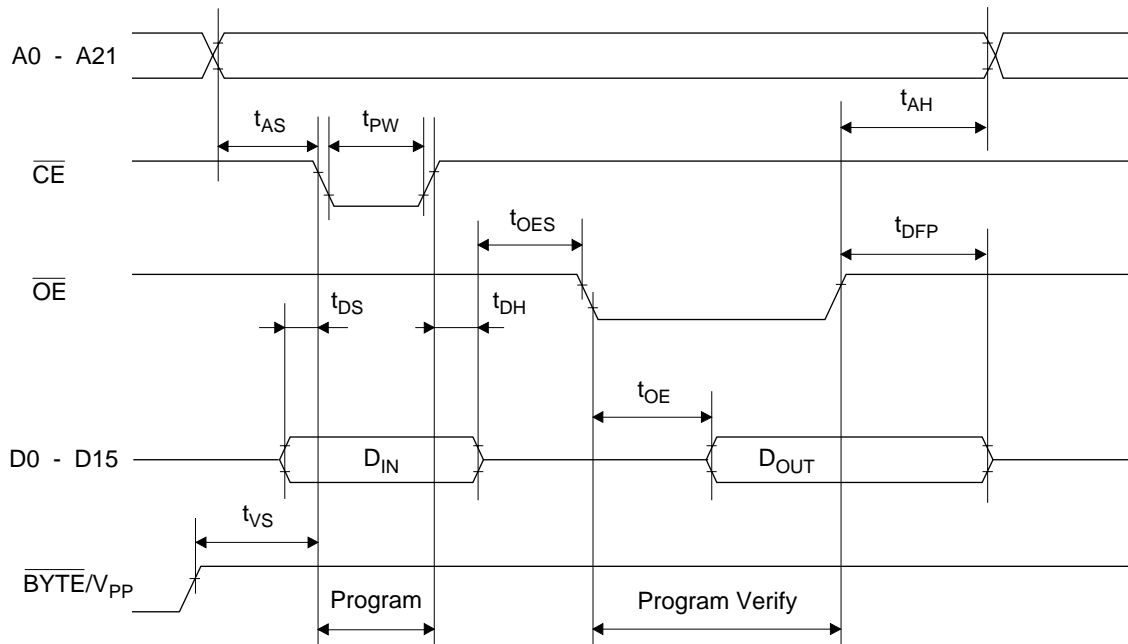

PIN Capacitance

($V_{CC}=3.3V$, $T_a=25^\circ C$, $f=1MHz$)

Parameter	Symbol	Condition	Min.	Typ.	Max.	Unit
Input	C_{IN1}	$V_I=0V$	-	-	12	pF
\overline{BYTE}/V_{PP}	C_{IN2}		-	-	120	
Output	C_{OUT}	$V_O=0V$	-	-	15	

Programming / Verify Flow Chart

Programming

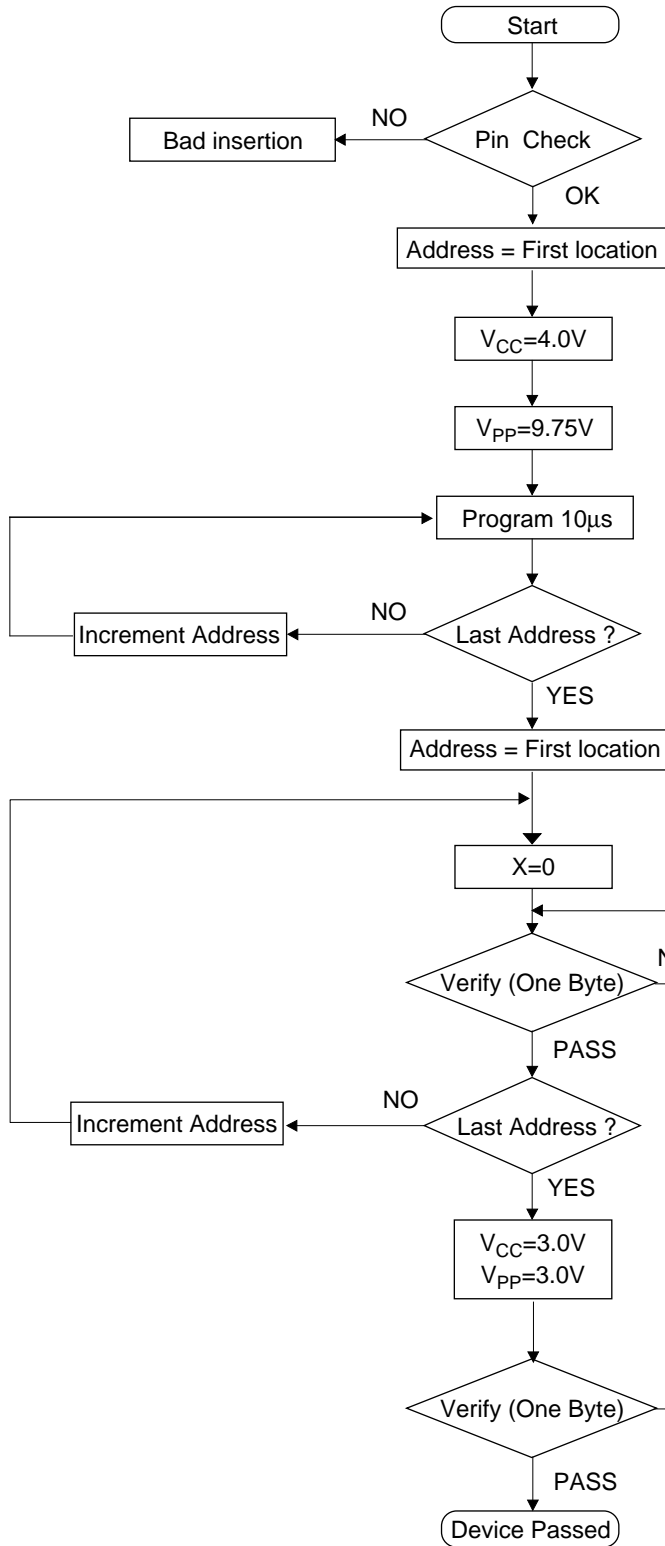

Verify

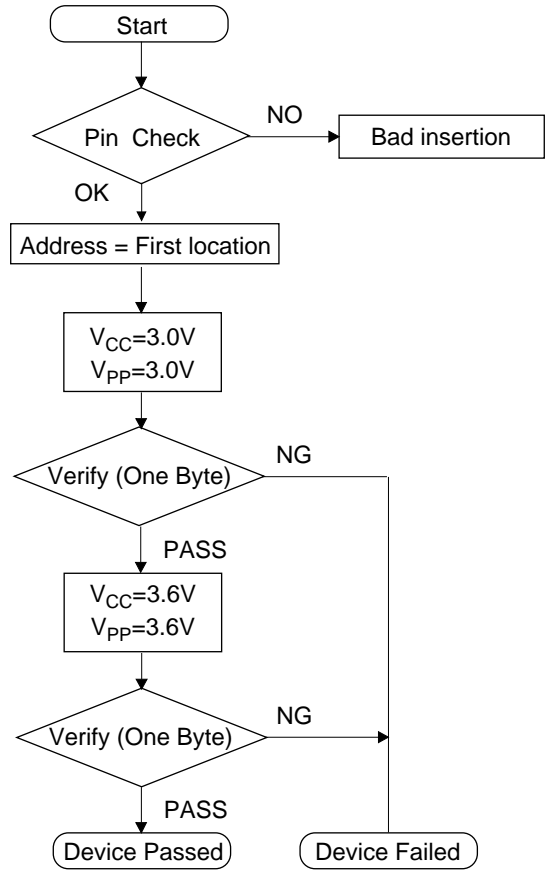

NOTICE

The information contained herein can change without notice owing to product and/or technical improvements. Before using the product, please make sure that the information being referred to is up-to-date.

The outline of action and examples for application circuits described herein have been chosen as an explanation for the standard action and performance of the product. When planning to use the product, please ensure that the external conditions are reflected in the actual circuit, assembly, and program designs.

When designing your product, please use our product below the specified maximum ratings and within the specified operating ranges including, but not limited to, operating voltage, power dissipation, and operating temperature.

Oki assumes no responsibility or liability whatsoever for any failure or unusual or unexpected operation resulting from misuse, neglect, improper installation, repair, alteration or accident, improper handling, or unusual physical or electrical stress including, but not limited to, exposure to parameters beyond the specified maximum ratings or operation outside the specified operating range.

Neither indemnity against nor license of a third party's industrial and intellectual property right, etc. is granted by us in connection with the use of the product and/or the information and drawings contained herein. No responsibility is assumed by us for any infringement of a third party's right which may result from the use thereof.

The products listed in this document are intended for use in general electronics equipment for commercial applications (e.g., office automation, communication equipment, measurement equipment, consumer electronics, etc.). These products are not authorized for use in any system or application that requires special or enhanced quality and reliability characteristics nor in any system or application where the failure of such system or application may result in the loss or damage of property, or death or injury to humans. Such applications include, but are not limited to, traffic and automotive equipment, safety devices, aerospace equipment, nuclear power control, medical equipment, and life-support systems.

Certain products in this document may need government approval before they can be exported to particular countries. The purchaser assumes the responsibility of determining the legality of export of these products and will take appropriate and necessary steps at their own expense for these.

No part of the contents contained herein may be reprinted or reproduced without our prior permission.

All brand, company and product names are the trademarks or registered trademarks of their respective owners.

ADDRESSES & SEMICONDUCTOR WEB SITES

OKI Electric Industry Co., Ltd.,

Device Business Group,
10-3, Shibaura, 4-chome,
Minato-ku, Tokyo 108, Japan,
Tel.: +81-(0)3-5445-6327,
Fax.: +81-(0)3-5445-6328,
<http://www.oki.co.jp/OKI/DBG/english/index.htm>
(NOTE: URL is case sensitive)

OKI Semiconductor Group,

785 North Mary Avenue,
Sunnyvale, CA 94086, U.S.A.,
Tel.: +1-408-720-1900,
Fax.: +1-408-720-1918,
<http://www.okisemi.com/>

OKI Electric Europe GmbH,

Head Office Europe,
Hellersbergstrasse 2,
D-41460 Neuss, Germany,
Tel: +49-2131-15960,
Fax: +49-2131-103539,
<http://www.oki-europe.de/>

OKI Electronics (Hong Kong) Ltd.,

Suite 1901-1&19, Tower 3,
China Hong Kong City,
33 Canton Road, Tsimshatsui,
Kowloon, Hong Kong,
Tel.: +852-2-736-2336,
Fax.: +852-2-736-2395

OKI Semiconductor (Asia) Pte. Ltd.,

78 Shenton Way 09-01,
Singapore 0207,
Tel.: +65-221-3722,
Fax.: +65-323-5376

OKI Semiconductor (Asia) Pte. Ltd.,

Taipei Branch,
7th Fl. No.260, Tun Hwa North Road,
Taipei, Taiwan, R.O.C.,
Sumitomo-Flysun Building,
Tel.: +886-2-2719-2561,
Fax.: +886-2-2715-2892
<http://www.oki.net.tw/>

For further information, please contact:

OKI

People To People Technology