

VI TELEFILTER**Filter specification****TFS 140G1****1/5****1. Measurement condition**

Ambient temperature T_A :	23 °C
Input power level:	0 dBm.
Terminating impedances at f_C *) :	for input: 102 Ω - 9,7 pF.
	for output: 122 Ω - 9,5. pF.
Source impedance:	50 Ω
Load impedance:	50 Ω

2. Characteristics

Remark:

Reference level for the relative attenuation a_{rel} of the **TFS 140G1** is the minimum of the pass band attenuation a_{min} . The minimum of the pass band attenuation a_{min} is defined as the insertion loss a_e . The reference frequency f_C is the arithmetic mean value of the upper and lower frequencies at the 3 dB filter attenuation level relative to the insertion loss a_e . The temperature coefficient of frequency Tc_f is valid both for the reference frequency f_C and the frequency response of the filter in the operating temperature range. The frequency shift of the filter in the operating temperature range is not included in the production tolerance scheme

Data	typ. value	tolerance / limit
Insertion loss (Reference level) a_e	20,5 dB	max. 25 dB
Centre frequency f_C at ambient temperature T_A (f_{CAT})	140,01 MHz	$140 \pm 0,09$ MHz
Pass band :	PB	$f_C - 0,85$ MHz..... $f_C + 0,85$ MHz
Amplitude ripple (p-p) in: f_C $f_C \pm 0,70$ MHz	0,5...0,6 dB	max. 1 dB
Bandwidth at ambient temperature:		
1 dB	1,50 MHz	min. 1,40 MHz
3 dB	1,74 MHz	min. 1,70 MHz
20 dB	2,29 MHz	
40 dB	2,55 MHz	max. 2,70 MHz
45 dB	2,65...3,10 MHz	max. 4,60 MHz
Relative attenuation a_{rel}		
f_C $f_C \pm 0,70$ MHz	0,6 dB	max. 1 dB
$f_C \pm 0,70$ MHz $f_C \pm 0,85$ MHz	2,5 dB	max. 3 dB
$f_C \pm 1,35$ MHz $f_C \pm 2,3$ MHz	45...55 dB	min. 40 dB
$f_C \pm 2,3$ MHz $f_C \pm 39$ MHz	52...60 dB	min. 45 dB
$f_C \pm 39$ MHz $f_C \pm 41$ MHz	65...70 dB	min. 60 dB
Group delay (mean value in PB):	2,55 μ s	max. 3,0 μ s
Group delay ripple in PB (p-p):	80 ns	max. 150 ns
Deviation from linear phase in PB (p-p):	1,8°...2,5° (r.m.s. 0,8°)	max. 6° p-p
S11 in PB :	2 dB	
S22 in PB :	2 dB	
Triple transit attenuation compared to main signal Crosstalk	50 dB	min. 40 dB
	55...65 dB	
Substrate material	Quartz	
Frequency inversion temperature (T_o)	25°...30° C	
Temperature coefficient of frequency (Tc_f)	-0,036...-0,045 ppm/K ²	
Frequency deviation of f_C over temperature: **)	$\Delta f_C(\text{Hz}) = Tc_f(\text{ppm/K}) \times (T - T_o)^2 \times f_{T_o}(\text{MHz})$	
Operating temperature range		- 40 °C ... + 85 °C
Storage temperature range		- 40 °C ... + 85 °C

*) The terminating impedances depend on parasitics and q-values of matching elements and the board used, and are to be understood as reference values only. Should there be additional questions do not hesitate to ask for an application note or contact our design team.

**) f_{T_o} is reference frequency f_C at frequency inversion temperature (T_o)

Generated: Dunzow W.

Checked / approved: Dr. Bert Wall

VI TELEFILTER

Potsdamer Straße 18

D 14 513 TELTOW / Germany

Tel: (+49) 3328 4784-0 / Fax: (+49) 3328 4784-30

E-Mail: tft@telefilter.com

VI TELEFILTER reserves the right to make changes to the product(s) and/or information contained herein without notice. No liability is assumed as a result of their use or application. No rights under any patent accompany the sale of any such product(s) or information.

3. Package : (all dimensions in mm)

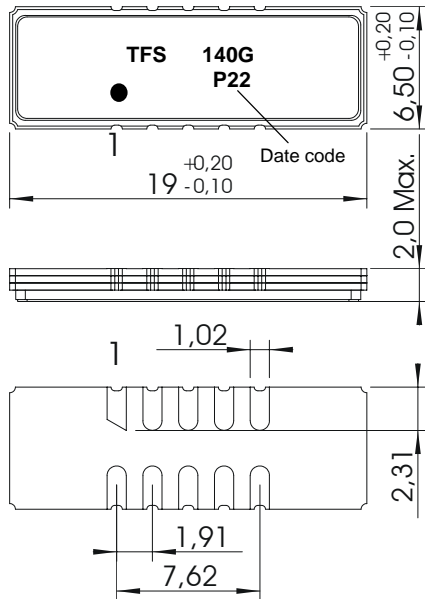

Date code: Year+week
 M 2001
 N 2001
 P 2002

Pin 10 **Input**
 Pin 1 Input RF Return
 Pin 5 **Output**
 Pin 6 Output RF Return
 Pin 2 - 4, 7 - 9 Package Ground

4. 50 Ω matching network (see Application Note) :

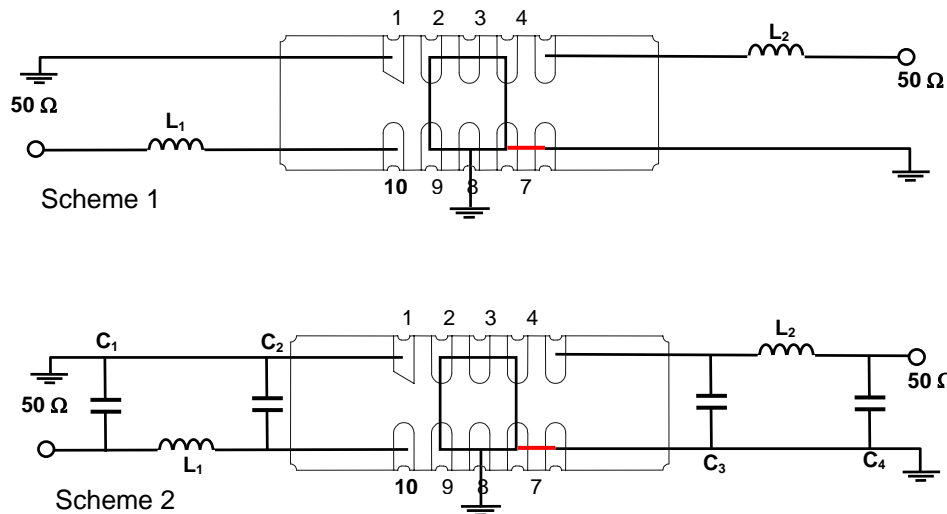

For final test we use scheme 1.

VI TELEFILTER

Potsdamer Straße 18

D 14 513 TELTOW / Germany

Tel: (+49) 3328 4784-0 / Fax: (+49) 3328 4784-30

E-Mail: tf@telefilter.com

VI TELEFILTER reserves the right to make changes to the product(s) and/or information contained herein without notice. No liability is assumed as a result of their use or application. No rights under any patent accompany the sale of any such product(s) or information.

5. Stability characteristics :

After the following tests the filter shall meet the whole specification:

1. Shock: 500g, 18 ms, half sine wave, 3 shocks each plane;
DIN IEC 68 T2 - 27
2. Vibration: 10 Hz to 500 Hz, 0,35 mm or 5g respectively, 1 octave per min, 10 cycles per plan, 3 plans;
DIN IEC 68 T2 - 6
3. Change of temperature: -55 °C to 125°C / 30 min. each / 10 cycles
DIN IEC 68 part 2 – 14 Test N
4. Resistance to solder heat (reflow): reflow possible: twice max.;
for temperature conditions refer to the attached "Air reflow temperature conditions" on page 4;

6. Packing :

Tape & Reel: DIN IEC 286 - 3, with exception of value for N and minimum bending radius;
tape type II, embossed carrier tape with top cover tape on the upper side;

max. pieces of filters per reel: 2000
reel of empty components at start: min 300 mm
reel of empty components at start including leader: min 500 mm
Trailer: min 300 mm

Tape (all dimensions in mm)

W	:	32	± 0,3
Po	:	4	± 0,1
Do	:	1,5	+ 0,1
E	:	1,75	± 0,1
So	:	28,4	± 0,1
F	:	14,2	± 0,1
G (min)	:	0,6	
P2	:	2	± 0,1
P1	:	12	± 0,1
D1(min)	:	2,0	
Ao	:	7,1	± 0,1
Bo	:	19,6	± 0,1
Ko	:	2,0	± 0,1
t	:	0,35	± 0,35
Ct	:	25,5	± 0,1

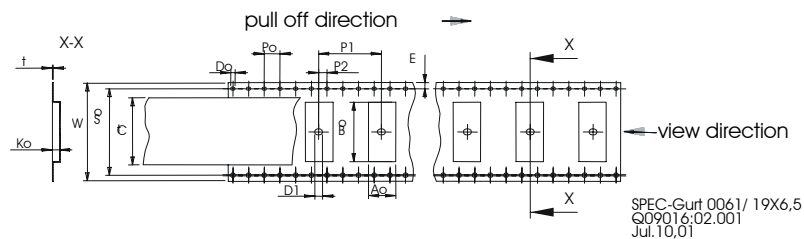

Reel (all dimensions in mm):

A	:	330
W1	:	32,4 + 2
W2(max)	:	38,4
N(min)	:	100
C	:	13 ± 0,5 / - 0,2

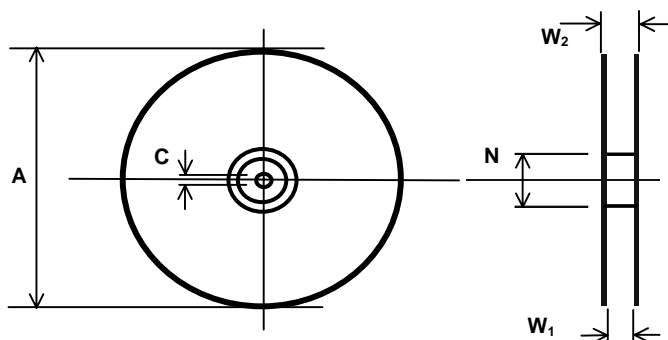

The minimum bending radius is 45 mm. The mounting surface of the filters faces the bottom side of the embossed carrier tape. Markings on the filters can be read if the upper side of the carrier tape is regarded with the sprocket holes on its right.

VI TELEFILTER

Potsdamer Straße 18

D 14 513 TELTOW / Germany

Tel: (+49) 3328 4784-0 / Fax: (+49) 3328 4784-30

E-Mail: tf@telefilter.com

VI TELEFILTER reserves the right to make changes to the product(s) and/or information contained herein without notice. No liability is assumed as a result of their use or application. No rights under any patent accompany the sale of any such product(s) or information.

7. Air reflow temperature conditions

1st and 2nd air reflow profile

Name:	pre-heating periods	main-heating periods	peak temperature
Temperature:	150 °C - 170 °C	over 200 °C	255 °C ± 5 °C
Time:	60 sec. - 90 sec.	20 sec. - 25 sec.	

Chip-mount air reflow profile

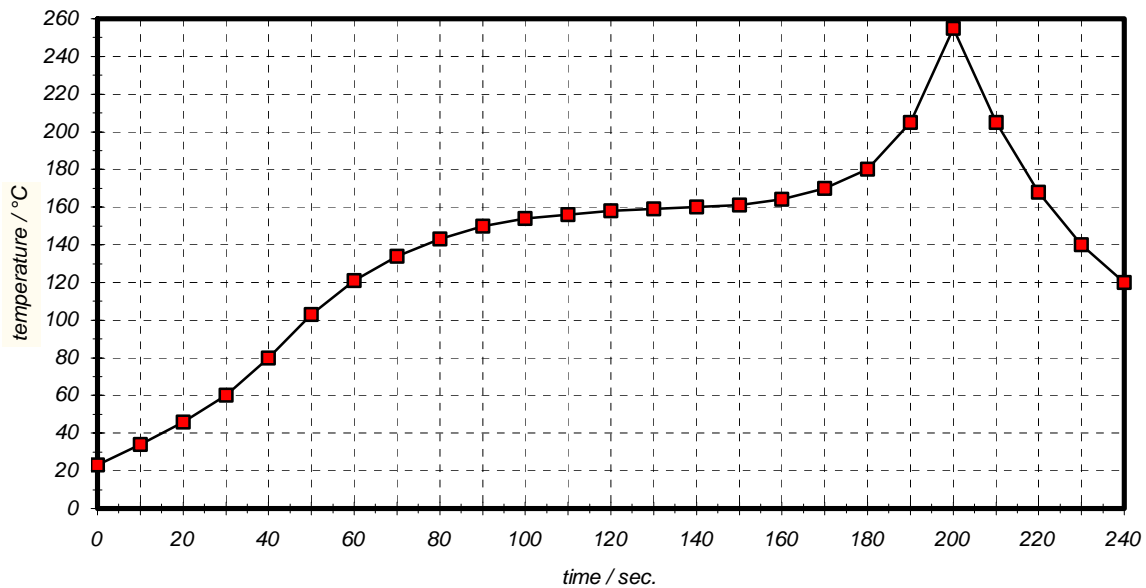

Table for temperature vs. time during the air reflow process

Tolerance of temperatures: ± 5 °C

time / sec.	temperature / °C	time / sec.	temperature / °C
0	23	140	160
10	34	150	161
20	46	160	164
30	60	170	170
40	80	180	180
50	103	190	205
60	121	195	230
70	134	200	255
80	143	205	230
90	150	210	205
100	154	215	180
110	156	220	165
120	158	230	140
130	159	240	120

VI TELEFILTER

Potsdamer Straße 18

D 14 513 TELTOW / Germany

Tel: (+49) 3328 4784-0 / Fax: (+49) 3328 4784-30

E-Mail: tf@telefilter.com

VI TELEFILTER reserves the right to make changes to the product(s) and/or information contained herein without notice. No liability is assumed as a result of their use or application. No rights under any patent accompany the sale of any such product(s) or information.

8. History :

Version	Reason of changes	Name	Date
1.0	Generate preliminary specification according to customer requirements.	Dunzow W.	15.01.2002
1.0	Generate filter specification after measured. Add typical filter values and termination impedances. Change matching configurations.	Dunzow W.	12.07.2002

VI TELEFILTER**Potsdamer Straße 18****D 14 513 TELTOW / Germany****Tel: (+49) 3328 4784-0 / Fax: (+49) 3328 4784-30****E-Mail: ft@telefilter.com**

VI TELEFILTER reserves the right to make changes to the product(s) and/or information contained herein without notice. No liability is assumed as a result of their use or application. No rights under any patent accompany the sale of any such product(s) or information.